



UNITED STATES DEPARTMENT OF COMMERCE
National Oceanic and Atmospheric Administration
COASTAL SERVICES CENTER
2234 Hobson Avenue, Charleston, SC 29405-2413



CSC Technical Report CSC/7-97/001 July 1997

NOAA CSC/CRS Cruise APR96FER: Gray's Reef Cruise

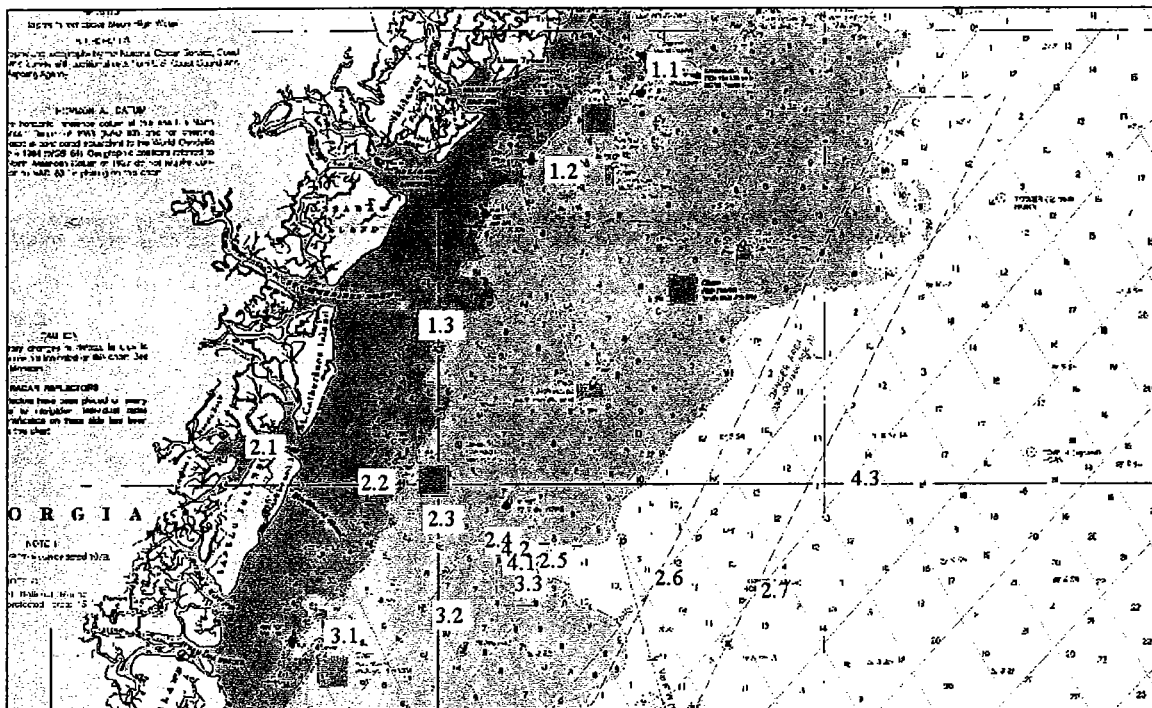

Participants:

Coastal Services Center - Coastal Remote Sensing Program
Gray's Reef National Marine Sanctuary
Skidaway Institute of Oceanography
Grice Marine Biological Laboratory

CSC Technical Report CSC/7-97/001

NOAA CSC/CRS Cruise APR96FER: Gray's Reef Cruise

Ajit Subramaniam¹
Kirk J. Waters²
Andrew W. Meredith³
Edward M. Armstrong¹
Reed M. Bohne⁴
William G. Keull²
James R. Nelson⁵
Giacomo R. DiTullio⁶
John C. Brock²

¹Technology Planning and Management
Corporation
2234 South Hobson Avenue
Charleston, SC 29405

²NOAA Coastal Services Center
2234 South Hobson Avenue
Charleston, SC 29405

³REMSA
2234 South Hobson Avenue
Charleston, SC 29405

⁴Gray's Reef National Marine Sanctuary
10 Ocean Science Circle
Savannah, GA 31411

⁵Skidaway Institute of Oceanography
10 Ocean Science Circle
Savannah, GA 31411

⁶Grice Marine Biological Laboratory
205 Fort John Road
Charleston, SC 29412

July 1997



UNITED STATES DEPARTMENT OF COMMERCE
National Oceanic and Atmospheric Administration
COASTAL SERVICES CENTER
2234 Hobson Avenue, Charleston, SC 29405-2413



This is a National Oceanic and Atmospheric Administration (NOAA) Coastal Services Center (CSC) Technical Report. The NOAA CSC Coastal Remote Sensing Program intends to publish forthcoming reports as official NOAA Technical Reports.

Abstract

The Gray's Reef National Marine Sanctuary (GRNMS) is one of the most popular recreational fishing and diving areas off the Georgia coast. Thus, primary production – the production rate of phytoplankton, the bottom of the food chain – and the water quality of this region are of great interest to sanctuary managers. These parameters impact fish populations and recreational diving. Ocean color satellites provide daily synoptic data of the region and could be a useful tool to sanctuary managers. However, for this tool to be truly useful, algorithms that relate satellite data to chlorophyll biomass, primary production, and water column visibility need to be developed and validated.

Measurements of surface chlorophyll pigment biomass, particulate absorption, dissolved organic material absorption, and spectral fluorescence were made during a cruise from April 22 to 25, 1996, in the vicinity of GRNMS. Water column profiles of temperature, conductivity, salinity, chlorophyll fluorescence, scattering, beam transmittance, upwelling radiance and downwelling irradiance were made at 16 stations.

Table of Contents

I. Introduction	1
II. Objective	1
III. Methods	1
A. Sampling Locations.....	1
B. Sampling Platform.....	1
C. Sample Collection Methods Summary.....	2
D. Sampling Gear.....	3
E. Bottle Samples.....	5
F. Optical Data Processing.....	9
G. Along-Track Measurements.....	9
IV. Results.....	10
A. Bottle Samples	10
B. Optical Data.....	16
V. Summary.....	16
VI. References	17
VII. Metadata	18
A. Core Documentation	18
B. Citation Information.....	20
C. Data Quality	21
D. Metadata Reference Information.....	23
VIII. Appendix A - Water Column Profile Data Figures.....	24
IX. Appendix B - Sub-Surface Light Field Estimation Statistics	25
X. Appendix C - Example Profile Header Information.....	29
XI. Appendix D - Calibration Certificates.....	33

List of Figures

Figure 1. Station Locations	2
Figure 2. Position of Instruments on the PRR Cage	6
Figure 3. Cabling Diagram for the PRR Cage	7
Figure 4. Particulate Absorption - April 22, 1996	12
Figure 5. Particulate Absorption - April 23, 1996	12
Figure 6. Particulate Absorption - April 24, 1996	13
Figure 7. Particulate Absorption - April 25, 1996	13
Figure 8. Dissolved Organic Matter Absorption - April 22, 1996.....	14
Figure 9. Dissolved Organic Matter Absorption - April 23, 1996.....	14
Figure 10. Dissolved Organic Matter Absorption - April 24, 1996.....	15
Figure 11. Dissolved Organic Matter Absorption - April 25, 1996.....	15

List of Tables

Table 1. Station Notes Indicating Date, Time, Location, Sky Conditions.....	3
Table 2. Sampling Details.....	4
Table 3. Center Wavelengths for the PRR System	5
Table 4. Surface Chlorophyll Concentration	10
Table 5. Surface Phytoplankton Pigment Concentration.....	11

Acknowledgments

Ship time was donated by Gray's Reef National Marine Sanctuary. Chlorophyll *a* and High Pressure Liquid Chromatography pigment analyses were conducted by Mark Geesey, Grice Marine Biological Laboratory. The help and cooperation of other members of the scientific party and the crew of the *R/V Ferrel* is gratefully acknowledged. A.S. is thankful to Lauren Parker for her very patient proofing of the text and editorial suggestions.

Data Usage Constraints

Users of this data are required to provide appropriate attribution in the form of co-authorship for any publications that use this data, unless formal permission to do otherwise is granted by NOAA/CSC.

I. Introduction

Gray's Reef is one of the largest nearshore live-bottom reefs off the southeastern United States. Gray's Reef National Marine Sanctuary (GRNMS) (32°22' to 31°25'N, 80°55' to 80°50'W) encompasses 58 square kilometers (km²) of live bottom habitat and is located 32 kilometers (km) off Sapelo Island. It is a very popular recreational fishing and sport diving destination (<http://www.skio.peachnet.edu/noaa/grnms.html>). Thus the water quality of this region in terms of chlorophyll biomass, diver visibility, and other such factors is of great interest to the sanctuary manager. Ocean color satellites provide daily synoptic data of some of these parameters and could be a useful tool to sanctuary managers. However, for this tool to be truly useful, algorithms that relate satellite data to chlorophyll biomass, primary production, and water column visibility need to be developed and validated.

II. Objective

The objective of this cruise was to determine the optical properties and variability within GRNMS and the surrounding area.

III. Methods

A description of the sample collection methods and of instruments used is detailed in the following sections.

A. Sampling Locations

Sixteen stations were occupied during the cruise from April 22 to 25, 1996 (Figure 1, Table 1). The cruise departed Savannah, Georgia on the afternoon of April 22 and proceeded to Sapelo Sound, occupying three stations along the way. On April 23, the vessel transited from Sapelo Sound, through GRNMS, to a Navy tower off shore, occupying seven stations along the way. April 24 was intended to include a high density sampling of GRNMS, but this was prevented by heavy weather. Three stations, from outside Altamaha Sound to inside the GRNMS, were sampled instead of the intended 10. On April 25, two stations were occupied within GRNMS and a third station approximately 25 km offshore was occupied.

B. Sampling Platform

The NOAA ship *Ferrel* (R492), a 41-meter (m) steel hull, twin screw, general purpose oceanographic research vessel, was used for this cruise. The *Ferrel* is specifically designed for coastal and inshore waters, and has a movable "A-Frame" and an oceanographic winch midship on the starboard side for deployment of equipment.

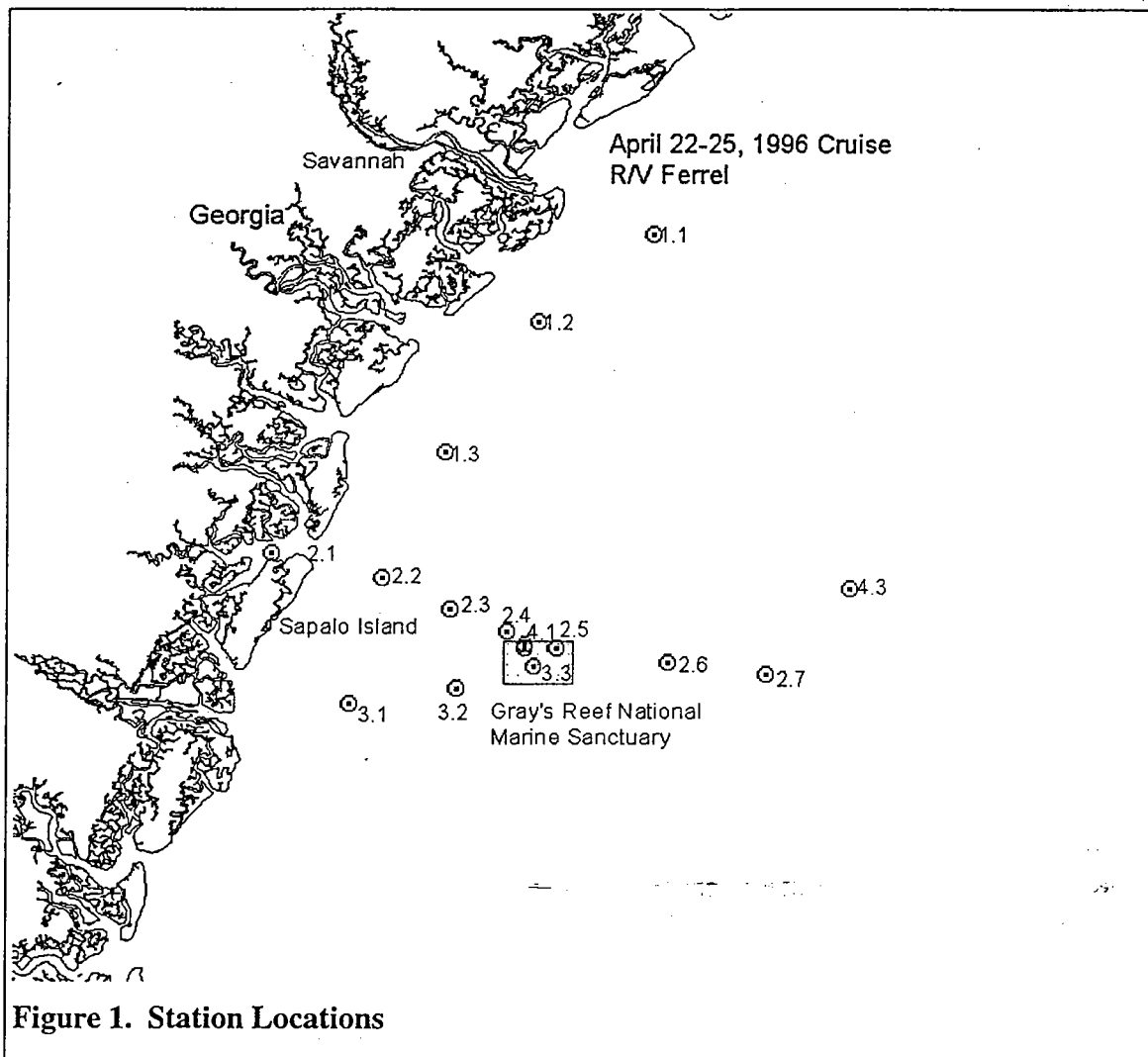

C. Sample Collection Methods Summary

The Profiling Reflectance Radiometer (PRR) cage, described below, was deployed on the starboard side of the *Ferrel* from a small "A-frame" with an oceanographic winch. The "A-frame" extended approximately 1 meter off the side of the ship. The deck sensor of the PRR system was located one deck above the "A-frame" and within 5 meters of it. The sensor did not fall under a shadow as long as the sun was not on the bow of the ship. The deck cell only recorded data during a cast. An along-track system was used to log position (latitude, longitude), time, course and speed of the vessel, temperature, salinity, and spectral fluorescence. The along-track system used water pumped through the ship's seawater intake system located about 1.5 meters below the surface. *In-situ* temperature, salinity, and density were also measured at some stations with a Conductivity-Temperature-Depth (CTD) sensor. Water samples for chlorophyll biomass,

Date	Station	Lat Deg	Lat Min	Latitude	Long Deg	Long Min	Longitude	Total Depth	Time On	Sky Conditions	Bucket SST (C)
4/22/96	1.1	31	57.90	31.965	-80	43.30	-80.722	15m	1552	clear	20.6
4/22/96	1.2	31	50.90	31.848	-80	52.51	-80.875	12m	1720	clear	21.7
4/22/96	1.3	31	40.35	31.673	-81	0.01	-81.000	12m	1851	clear	19.6
4/23/96	2.1	31	32.36	31.539	-81	14.05	-81.234	4m	750	clear	21.9
4/23/96	2.2	31	30.32	31.505	-81	5.11	-81.085	7m	947	clear	19.6
4/23/96	2.3	31	27.86	31.464	-80	59.58	-80.993	12m	1040	clear	
4/23/96	2.4	31	26.03	31.434	-80	54.98	-80.916	15m	1202	clear	19.9
4/23/96	2.5	31	24.62	31.410	-80	50.99	-80.850	19m	1318	high clouds	19.6
4/23/96	2.6	31	23.52	31.392	-80	42.04	-80.701	20m	1500	high clouds	19.9
4/23/96	2.7	31	22.55	31.376	-80	33.98	-80.566	28m	1610	high clouds	20.0
4/24/96	3.1	31	20.12	31.335	-81	7.70	-81.128	12m	1030	clear	18.5
4/24/96	3.2	31	21.46	31.358	-80	59.14	-80.986	18m	1203	clear	17.7
4/24/96	3.3	31	23.15	31.386	-80	52.77	-80.880	20m	1315	clear	18.5
4/25/96	4.1	31	24.66	31.411	-80	53.58	-80.893	17m	910	high clds	19.0
4/25/96	4.2	31	25.01	31.417	-80	53.58	-80.893	17m	930	high clds	19.0
4/25/96	4.3	31	29.50	31.492	-80	27.23	-80.454	31m	1240	clear	19.6

Table 1. Station Notes Indicating Date, Time, Location, Sky Conditions

Lat Deg, Lat Min, Long Deg, and Long Min refer to the station position in degrees and minutes, Latitude and Longitude refer to the station position in decimal degrees. Total depth is the water depth at station, Time On is when station was occupied (EDT), and Bucket SST is the sea surface temperature measured at station.

phytoplankton pigments, particulate absorption, dissolved organic matter absorption, total suspended solids, particulate organic carbon, and particulate organic nitrogen were obtained from just below the sea surface using a Niskin bottle. Sea surface temperature was taken from a mercury thermometer mounted in a bucket dipped in the ocean for the duration of the stay at a station. The parameters measured are summarized in Table 2.

D. Sampling Gear

The PRR cage (Figures 2) contained a split PRR600s (Serial No. 9643) that measured seven channels of downwelling irradiance, seven channels of upwelling radiance, depth, tilt, roll, and temperature. A reference surface unit (PRR610 Serial No. 9644) that measured seven matched channels of surface downwelling irradiance on deck was also used. Channels 1 to 6 were narrow band (10-nanometer [nm] full width half maximum [FWHM]) centered at the indicated wavelengths, while channel 7 on the downwelling sensor and PRR610 measured broad band Photosynthetically Available Radiation (PAR) (400 to 700 nm).

Date	Station	Latitude	Longitude	PRRFile	SamDep	Chl	HPLC Ap	ADOM	POC/ TSS	CTD	PRR
4/22/96	1.1	31.965	-80.722	P960422A	surface	3	2	3	2	0	1
4/22/96	1.2	31.848	-80.875	P960422B	surface	3	1	1	3	0	1
4/22/96	1.3	31.673	-81.000	P960422C	surface	3	2	3	3	0	1
4/23/96	2.1	31.539	-81.234	P960423A	surface	3	1	1	3	3	1
4/23/96	2.2	31.505	-81.085	P960423B	surface	3	2	3	3	0	1
4/23/96	2.3	31.464	-80.993	P960423C	surface	3	2	3	3	0	1
4/23/96	2.4	31.434	-80.916	P960423D	surface	3	2	3	3	0	1
4/23/96	2.5	31.410	-80.850	P960423E	surface	3	1	1	3	0	1
4/23/96	2.6	31.392	-80.701	P960423F	surface	3	2	3	3	0	1
4/23/96	2.7	31.376	-80.566	P960423G	surface	3	2	3	3	0	1
4/24/96	3.1	31.335	-81.128	P960424A	surface	3	2	3	3	0	1
4/24/96	3.2	31.358	-80.986	P960424B	surface	3	2	3	3	0	1
4/24/96	3.3	31.386	-80.880	P960424C	surface	3	1	3	3	0	1
4/25/96	4.1	31.411	-80.893	P960425A	surface	3	1	3	3	0	1
4/25/96	4.2	31.417	-80.893	P960425B	surface	0	0	0	0	0	1
4/25/96	4.3	31.492	-80.454	P960425C	surface	3	1	3	3	0	1

Table 2. Sampling Details

PRRFile: file name containing the raw data acquired by the instruments in the PRR cage

SamDep: depth at which water sample was taken

Chl: chlorophyll biomass determined by fluorescence of extracted chlorophyll

HPLC: phytoplankton pigment concentration determined by High Pressure Liquid Chromatography technique

Ap: absorption of particulate material

ADOM: absorption of dissolved material

POC/PON: particulate organic Carbon, particulate organic Nitrogen concentrations

TSS: total suspended solids

CTD: measurements made with a SeaBird SEACAT profiler

PRR: measurements by the instruments on the PRR cage

The numbers below each of these measurement types refer to the number of samples obtained for each of these measurements.

Channel No.	PRR600s Downwelling Light Sensor	PRR600s Upwelling Light Sensor	PRR610
1	380 nm	380 nm	380 nm
2	412 nm	412 nm	412 nm
3	443 nm	443 nm	443 nm
4	490 nm	490 nm	490 nm
5	510 nm	510 nm	510 nm
6	555 nm	555 nm	555 nm
7	PAR	683 nm	PAR

Table 3. Center Wavelengths for the PRR System

The cage also contained a 10-centimeter (cm) pathlength, 660-nm Light Emitting Diode (LED)-based SeaTech transmissometer (Serial No. 664), a Biospherical Instruments Quantum Scalar Profiling sensor (QSP200, Serial No. 4443), a SeaTech light scattering sensor (LSS, Serial No. 281), and a WETLabs Wetstar chlorophyll fluorometer (Serial No. Ws3-088). Water was drawn through the fluorometer using a SeaBird pump (Serial No. 051363) running at 2,000 revolutions per minute (RPM). The data from all these instruments were multiplexed through the PRR600s such that each record contained a depth and parameters from every instrument. Figure 3 shows the cabling diagram for these instruments. The calibration history for these instruments is given in Appendix D.

E. Bottle Samples

Discrete water samples were taken from the near surface at each station using Niskin bottles. Sample volumes indicated in Tables 4 and 5 were filtered through glass fiber (GF/F) filters for chlorophyll concentration and phytoplankton pigment concentration respectively. Water was filtered on board and the filters were frozen in liquid nitrogen for later analysis in the lab. No water was taken for station 4.2 and the sample for station 4.1 was lost. The samples were cold extracted in 90-percent acetone for 12 hours in the dark and the chlorophyll concentration was determined fluorometrically with a Turner Designs AU10 fluorometer using the method of Welschmeyer (1994).

The phytoplankton pigment sample filter was cut into small pieces with a razor blade and ground in a 1.5-milliliter (mL) microcentrifuge tube with 1.5-mL 90-percent acetone (10-percent water). The microcentrifuge tube was placed in a freezer (-20°C) for a minimum of two hours to extract completely. The samples were centrifuged at 0°C and 20,000g for 15 minutes using a Heraeus Biofuge 15R ultracentrifuge. After centrifugation, 0.5mL was filtered using a Nalgene nylon membrane filter (pore size 0.2 micrometer [μm]) into an High Pressure Liquid Chromatograph (HPLC) injection vial. The sample was diluted to 60 percent acetone with the addition of 0.25mL of water. 0.5mL was then injected into the HPLC.

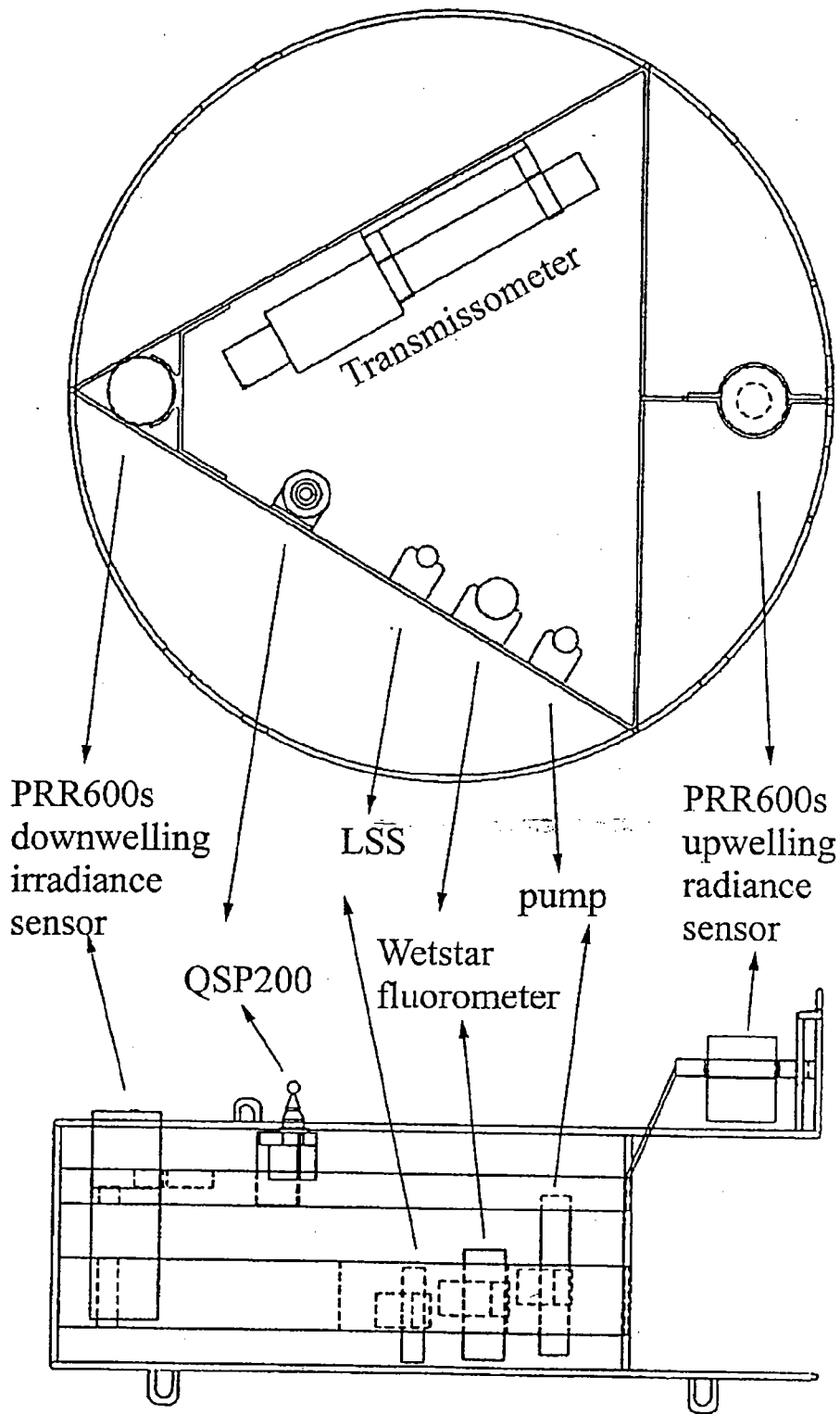

Figure 2. Position of Instruments on the PRR Cage (Figure adapted from BSI manual)

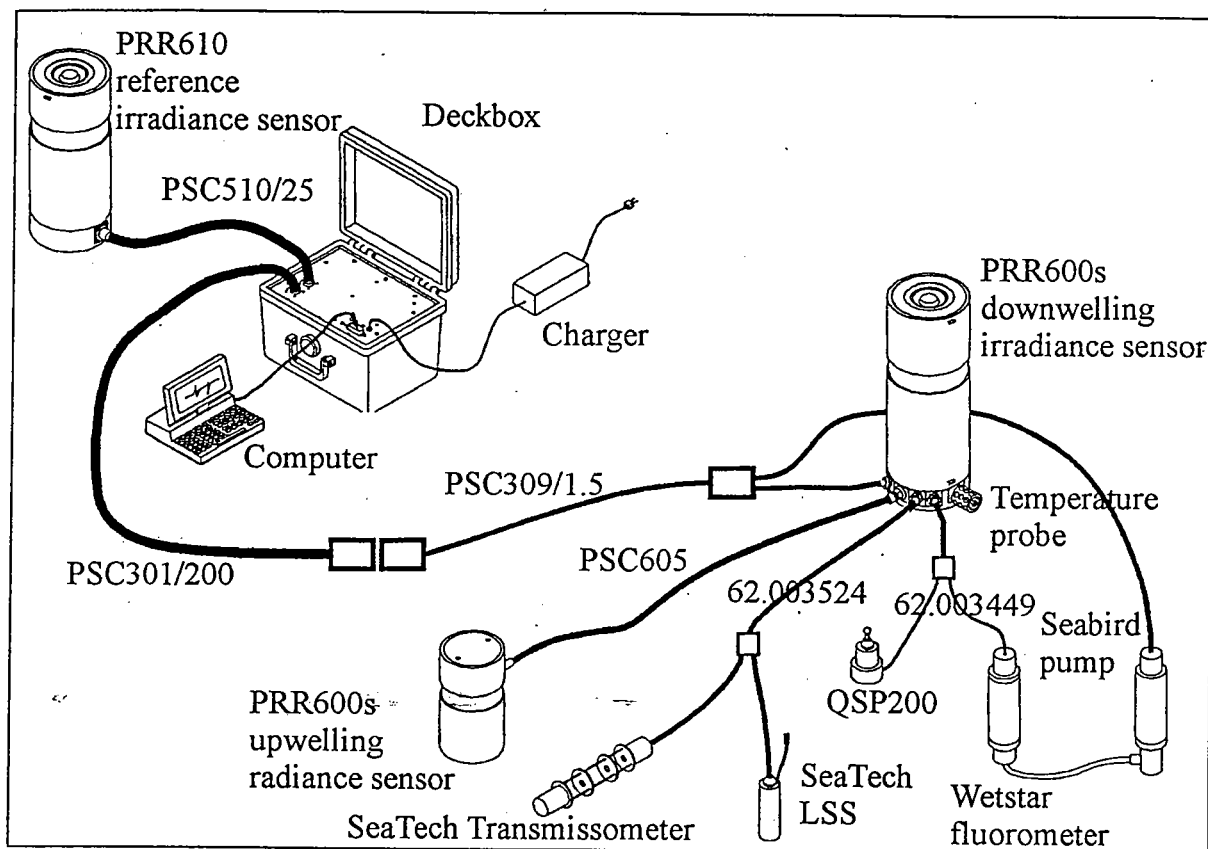

Figure 3. Cabling Diagram for the PRR Cage (Figure adapted from BSI manual)

A Hewlett-Packard 1050 Series HPLC with a Phenomenex Sphericlone ODS(2) reverse-phase column (250 millimeter [mm] x 4.6 mm with 5 μ m particles) was used with a ternary gradient to separate and identify the pigments. The three solutions were: A: Water; B: Methanol; C: 85-percent Methanol/15-percent 0.5-Molar (M) Ammonium Acetate (pH 7.6). The 41-minute gradient method was as follows:

Time (minute)	%A	%B	%C	Flow Rate (mL/minute)
0	2	0	98	1.0
5	2	0	98	1.0
6	15	85	0	1.0
10	10	90	0	1.25
30	0	100	0	1.25
36	0	100	0	1.9
39	0	100	0	1.9
39.5	2	0	98	1.5
41	2	0	98	1.0

A diode array detector recorded spectra every five seconds at wavelengths from 350 to 600 nm. Chromatograms were monitored at 440 nm (for carotenoids and chlorophylls) and 405 nm (for chlorophyllides, phaeophorbides, and phaeophytins). In addition, a

fluorescence detector measured fluorescence at 666 nm using an excitation at 421 nm (maximized for chlorophyll *a*). The system was calibrated using known concentrations of pigments extracted from algal cultures maintained in the lab or purchased from commercial facilities. The system has been calibrated for the following carotenoids: peridinin, 19'-butanoyloxyfucoxanthin, fucoxanthin, 19'-hexanoyloxy fucoxanthin, diadinoxanthin, alloxanthin, diatoxanthin, lutein, and zeaxanthin. It has also been calibrated for chlorophylls *a*, *b*, and *c1+c2* (which co-elute), and the chlorophyll *a* degradation products chlorophyllide, phaeophytin, and 3 phaeophorbides. Details of the method can be found in Wright *et al.* (1991).

Sea water was filtered through baked GF/F in to a glass Erlenmeyer flask on the ship for dissolved organic matter absorption (A_{cdom}) samples. The filtrate was refrigerated in amber glass bottles that had been rinsed in distilled water and then baked in a muffle furnace at 450°C. The Erlenmeyer flask was rinsed with distilled water between samples. In the lab, the samples were filtered through 0.2- μm Nuclepore (using the first 40 to 50 mL for several rinses of the glassware). A 10-cm path length cuvette in a dual-beam spectrophotometer (Perkin-Elmer Lambda 6) was used to measure the absorption from 250 nm to 750 nm. The reference used was 0.2- μm filtered HPLC grade water. The average optical density (OD) from 700 to 750 nm was subtracted as the baseline value.

Sea water was filtered through GF/F filters for particulate absorption (A_p) samples. The filters were carefully rolled into cryovials and stored in liquid nitrogen (N_2) for subsequent analysis in the lab. The absorption spectrum was measured from 250 to 850 nm using a dual-beam spectrophotometer equipped with a scattered-transmittance accessory (end-on photomultiplier tube [PMT] with sample compartment and diffusing plate immediately in front of the PMT window [Perkin-Elmer Lambda 6]), in accordance with the SeaWiFS protocol (Mueller and Austin 1995). Details of the methods followed are described in Nelson and Guarda (1995). Beta correction for this specific instrument was determined using suspended versus filtered samples for cultured phytoplankton, and had the polynomial formulation of Mitchell (1990) and Cleveland and Weidemann (1993).

For measurement of total suspended solids (TSS), 500 to 1500 mL of sea water (volume filtered indicated in Table 6) was filtered through prerinsed, dried, and preweighed Millipore HA filters (nominally 0.45 μm) following methods described in Strickland and Parsons (1972). Offshore stations required more water than could be filtered in the transit time between stations and hence TSS was not measured at these stations.

Sea water (volume filtered indicated in Table 7) was filtered through 25-mm diameter precombusted (450°C) GF/F filters at each station for the determination of particulate organic carbon (POC) and particulate organic nitrogen (PON). The samples were stored in a freezer following filtration in combusted glass vials. In the lab, the samples were freeze dried, placed in tin capsules, then analyzed with a Fisons NA-1500 Series 2 CNS analyzer. The standard used for these samples was 2,5 Bis(5-tert-butyl-bezoxazol-2-yl) thiophene (BBOT).

F. Optical Data Processing

The PRR data was processed using the Bermuda Bio-Optics Project (BBOP) processing software (Siegel *et al.*, 1995). A least common denominator (LCD) file was created from the binary data files, the cast card files, the calibration files, and cruise notes. The LCD file header contains the metadata for the cast and includes information on the parameters sampled, parameters derived, filters used, and the statistical results of the regression used to extrapolate light to the sub-surface. An example header is presented in Appendix C. The pressure channel data was recalculated using an offset to adjust for the distance of the pressure sensor from the cosine collector. The tops and bottoms of the individual profiles were marked using an interactive Matlab[®] script and the corresponding record numbers were inserted into the LCD header section. Data less than the dark threshold was replaced by -9.9×10^{35} . Then the data was quality controlled using flags for data with tilt and roll angles greater than 10° (flag value greater than 0 in the "aq-1Tilt-1Roll" field), and records where the surface incident irradiance was not uniform (flag value greater than 0 in the "kq-1ed412" field). The temperature, transmissometer, and fluorometer data were despiked, in two passes, with a difference threshold. A moving average was calculated for these channels. The data were separated into upcast and downcast profiles and then binned to 0.5-m bins. Spectral attenuation coefficients were calculated for the optical channels over a five-point moving window. Sub-surface downwelling irradiance and upwelling radiance were extrapolated to just below the surface using data from the top 3 meters. The statistics for calculation of sub-surface irradiance and radiance are shown in Appendix B.

G. Along-Track Measurements

The along-track measurement system used the ship's sea water intake system and pump with the output redirected into a 5-gallon bucket located in the wet lab sink. A Hydrolab Datasonde 3 Multiprobe logger (Serial No. 25435) and a WETLabs SAFire (Serial No. SAF106) were placed in the bucket and the water overflow was directed down the sink. A SeaBird pump (Serial No. 051466) running at 3,000 RPM pushed water from the bucket through the SAFire flow tube. The Datasonde recorded temperature, salinity, pH, and turbidity (in normalized turbidity units [NTU]) every five minutes. The SAFire recorded fluorescence with six excitation wavelengths (228, 265, 313, 375, 430, 490 nm) and 16 emission wavelengths (228, 265, 313, 340, 365, 400, 430, 460, 490, 510, 540, 590, 620, 650, 690, 810 nm) every two minutes. The SAFire was used on April 24 and 25. The ship's Differential Global Positioning System (DGPS) was used to log the date, time, position (latitude, longitude), and the course and speed of the vessel. This data was binned to five minute intervals. The time stamps in the DGPS files were used to match the times in the Datasonde and SAFire records to create along-track records containing all the measured parameters. All DGPS records for April 25 were lost due to a computer crash prior to file closure.

IV. Results

The measurements shown here were from a variety of waters types, ranging from the extremely turbid inshore waters of Sapelo Sound (station 2.1) to the clear mdi-shelf waters (station 4.3).

A. Bottle Samples

The surface chlorophyll concentration measured at the various stations are shown in Table 4 and the surface phytoplankton pigment concentration in Table 5. There are large differences in the chlorophyll *a* values obtained by HPLC technique, both between duplicates from the same station, and when compared to chlorophyll *a* concentrations obtained fluorometrically. These discrepancies are under investigation. Particulate absorption measurements are shown in Figures 4, 5, 6, and 7. The dissolved organic matter absorption measurements are shown in Figures 8, 9, 10, and 11. The coastal stations (1.1, 1.2, 1.3, 2.1, 2.2, 2.3, and 3.1) can be clearly delineated from the off-shore stations (2.4, 2.5, 2.6, 2.7, 3.2, 3.3, 4.1, 4.2, and 4.3).

Date	Station	Volume Filtered (mL)	Sample A	Sample B	Sample C	Average (mg/L)
4/22/96	1.1	150	3.033	3.313	3.033	3.126
4/22/96	1.2	150	3.967	3.967	3.920	3.951
4/22/96	1.3	150	3.967	3.453	3.733	3.718
4/23/96	2.1	100	22.820	17.360	17.290	19.157
4/23/96	2.2	200	4.165	4.970	4.445	4.527
4/23/96	2.3	150	3.127	3.080	3.267	3.158
4/23/96	2.4	200	1.225	0.770	0.735	0.910
4/23/96	2.5	250	0.560	0.560	0.532	0.551
4/23/96	2.6	250	0.700	0.616	0.532	0.616
4/23/96	2.7	250	0.532	0.476	0.504	0.504
4/24/96	3.1	150	3.593	3.407	3.407	3.469
4/24/96	3.2	250	1.372	1.316	1.400	1.363
4/24/96	3.3	250	1.092	1.092	1.064	1.083
4/25/96	4.3	250	0.672	0.532	0.616	0.607

Table 4. Surface Chlorophyll Concentration

Station	Volume Filtered (l)	Chl c3	Chl c1+2	Perid	19'-But	Fucox	19'-Hex	Diadin	Zeax	Lutein	Chl b	Chl a	Chl-ide	Ph-ide x1	Ph-ide x2	Ph-ide x3	Ph-tin
1.1b	2.325	0.161	0.309	0.015	0.062	0.453	0.110	0.044	0.105	0.008	0.095	0.652	0.295	0.037	0.003	0.015	0.005
1.1c	2.37	0.123	0.229	0.010	0.046	0.320	0.088	0.034	0.066	0	0.057	0.399	0.195	0.143	0.001	0.015	0.005
1.2b	2.325	0.091	0.200	0.013	0.027	0.308	0.060	0.023	0.050	0.005	0.022	0.096	0.193	0.026	0.003	0.016	0.005
1.3a	1.500	0.127	0.244	0.013	0.028	0.388	0.097	0.042	0.174	0	0.026	0.344	0.124	0.033	0	0.020	0.018
1.3b	1.500	0.128	0.234	0.016	0.036	0.357	0.082	0.044	0.149	0.010	0.066	0.364	0.068	0.028	0	0.043	0.010
2.1c	0.900	0.080	1.178	0.080	0	1.850	0.053	0.093	0.083	0.032	0	0.748	0.785	0.200	0.007	0.218	0.104
2.2a	2.325	0.113	0.276	0.019	0.022	0.414	0.059	0.04	0.176	0.011	0.086	0.368	0.100	0.043	0	0.035	0.011
2.2b	2.325	0.081	0.225	0.016	0.018	0.342	0.057	0.026	0.080	0	0	0.140	0.256	0.045	0.001	0.038	0.008
2.3a	2.325	0.067	0.173	0.007	0.017	0.017	0.050	0.024	0.110	0.005	0	0.082	0.156	0.093	0.007	0.022	0.010
2.3b	2.325	0.064	0.151	0.007	0.014	0.228	0.041	0.024	0.189	0.012	0.033	0.307	0.054	0.026	0	0.017	0.014
2.4b	2.825	0.026	0.054	0.004	0.005	0.090	0.016	0.006	0.041	0	0	0.052	0.015	0.005	0	0	0.003
2.4c	2.870	0.023	0.059	0.004	0.005	0.070	0.02	0.006	0.046	0	0	0.080	0.025	0.007	0	0	0
2.5b	4.595	0.013	0.027	0.001	0.003	0.044	0.011	0.004	0.023	0	0	0.038	0.019	0.084	0.003	0	0
2.6b	4.596	0.020	0.036	0.002	0.004	0.051	0.020	0.006	0.038	0	0	0.034	0.011	0.005	0	0	0.003
2.6c	4.612	0.020	0.035	0.002	0.006	0.060	0.021	0.007	0.035	0	0	0.044	0.032	0.007	0	0	0.003
2.7a	4.608	0.019	0.034	0.001	0.004	0.057	0.016	0.005	0.018	0	0	0.037	0.039	0.007	0	0	0
2.7b	4.612	0.018	0.037	0.003	0.005	0.056	0.017	0.005	0.033	0	0	0.048	0.019	0.004	0	0	0.003
3.1a	2.325	0.099	0.251	0.012	0.012	0.498	0.040	0.028	0.104	0	0.030	0.301	0.116	0.169	0	0.038	0.007
3.1b	2.325	0.104	0.266	0.013	0.016	0.510	0.041	0.021	0.058	0	0	0.057	0.196	0.037	0.004	0.033	0.013
3.2a	2.325	0.043	0.106	0.006	0.009	0.157	0.021	0.011	0.034	0	0	0.037	0.081	0.013	0	0.003	0
3.2b	2.325	0.04	0.086	0.008	0.007	0.145	0.020	0.011	0.053	0	0	0.129	0.027	0.010	0	0.007	0.004
3.3c	2.370	0.039	0.080	0.007	0.006	0.123	0.018	0.009	0.034	0	0	0.027	0.051	0.009	0	0	0
4.1b	2.325	0.029	0.067	0.003	0.005	0.099	0.007	0.009	0.030	0	0	0.020	0.033	0.011	0	0	0
4.3c	4.612	0.012	0.029	0	0.003	0.050	0.009	0.005	0.034	0	0	0.030	0.015	0.009	0.001	0	0

Table 5. Surface Phytoplankton Pigment Concentration

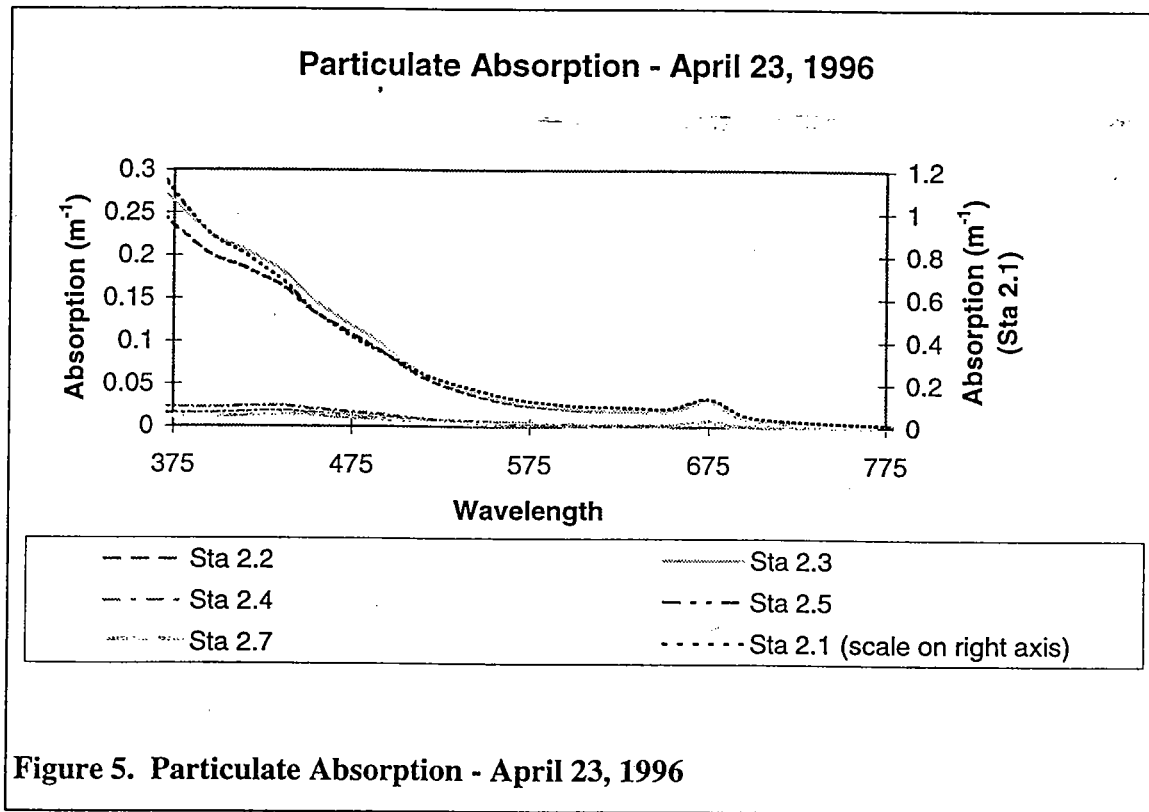
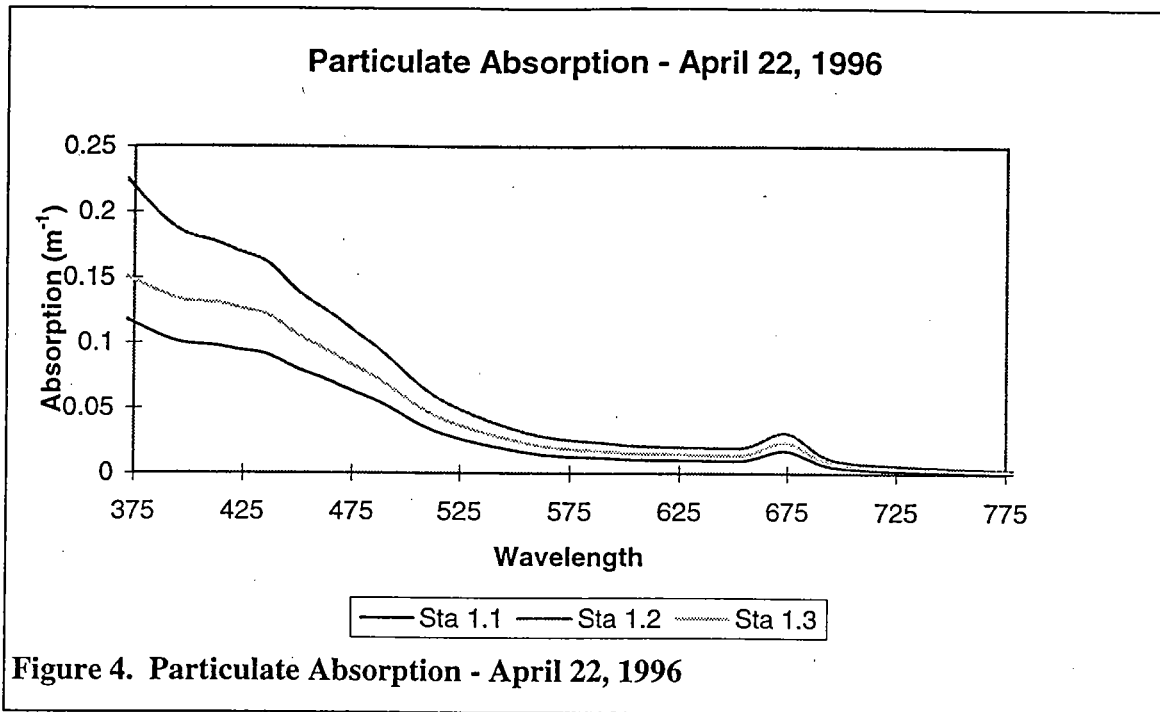

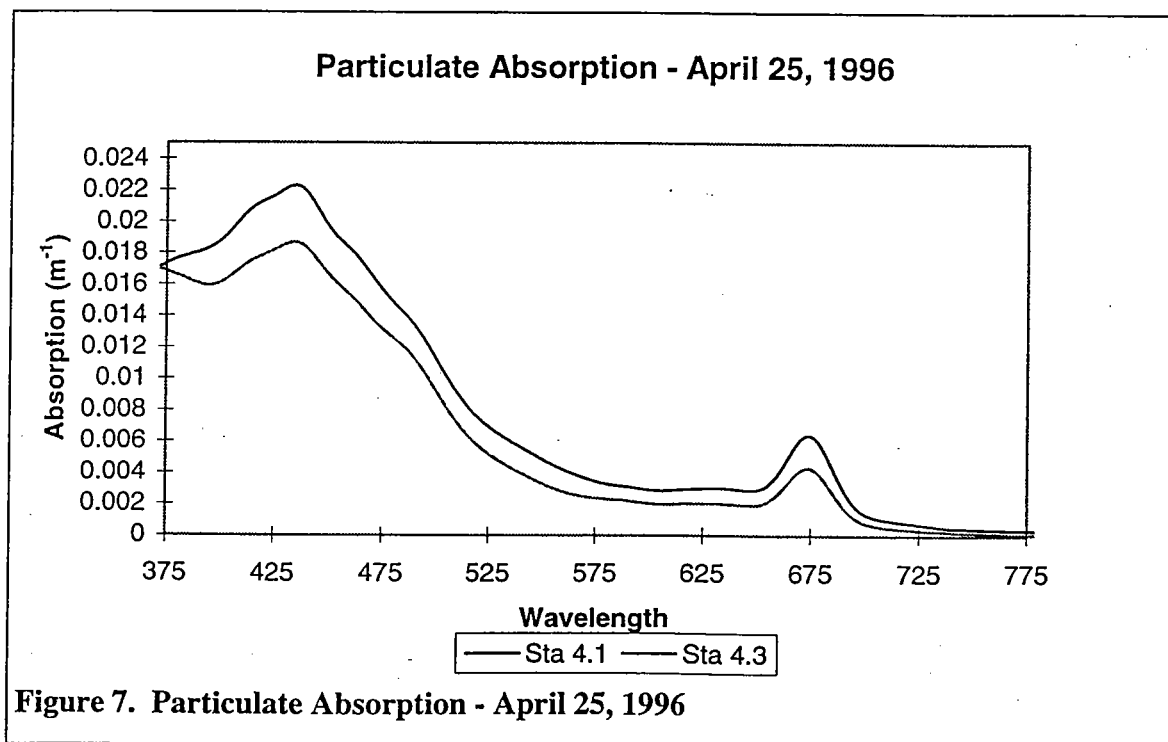
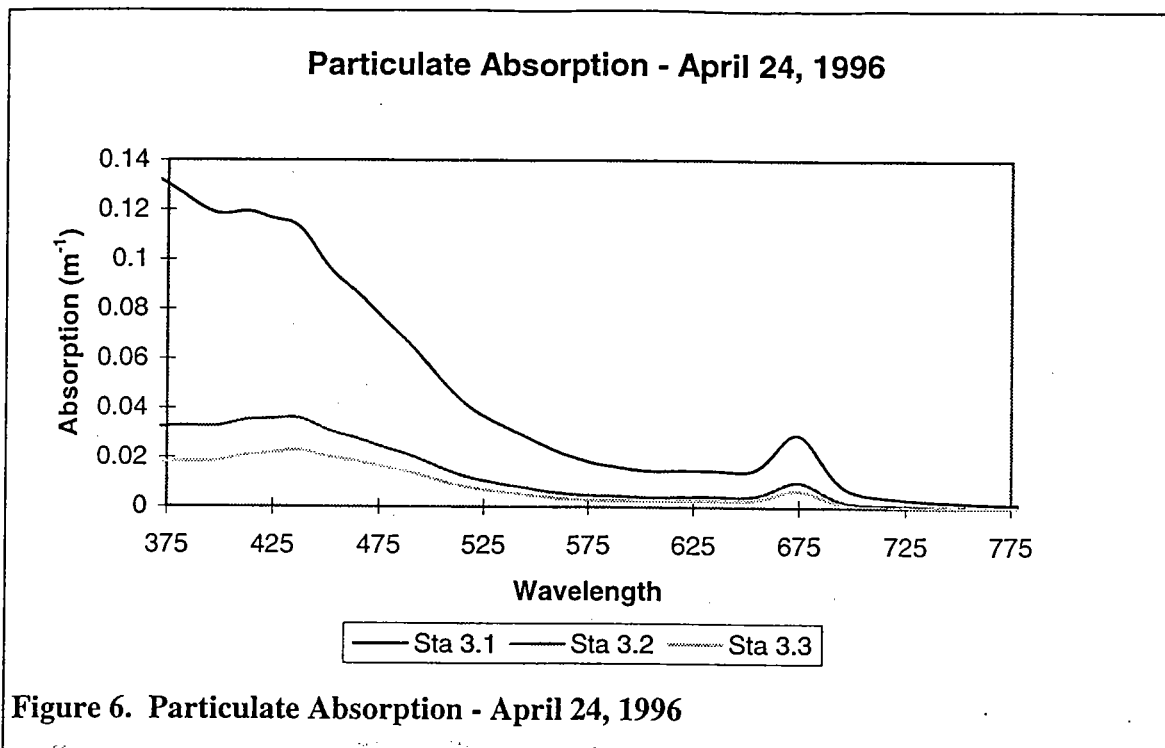

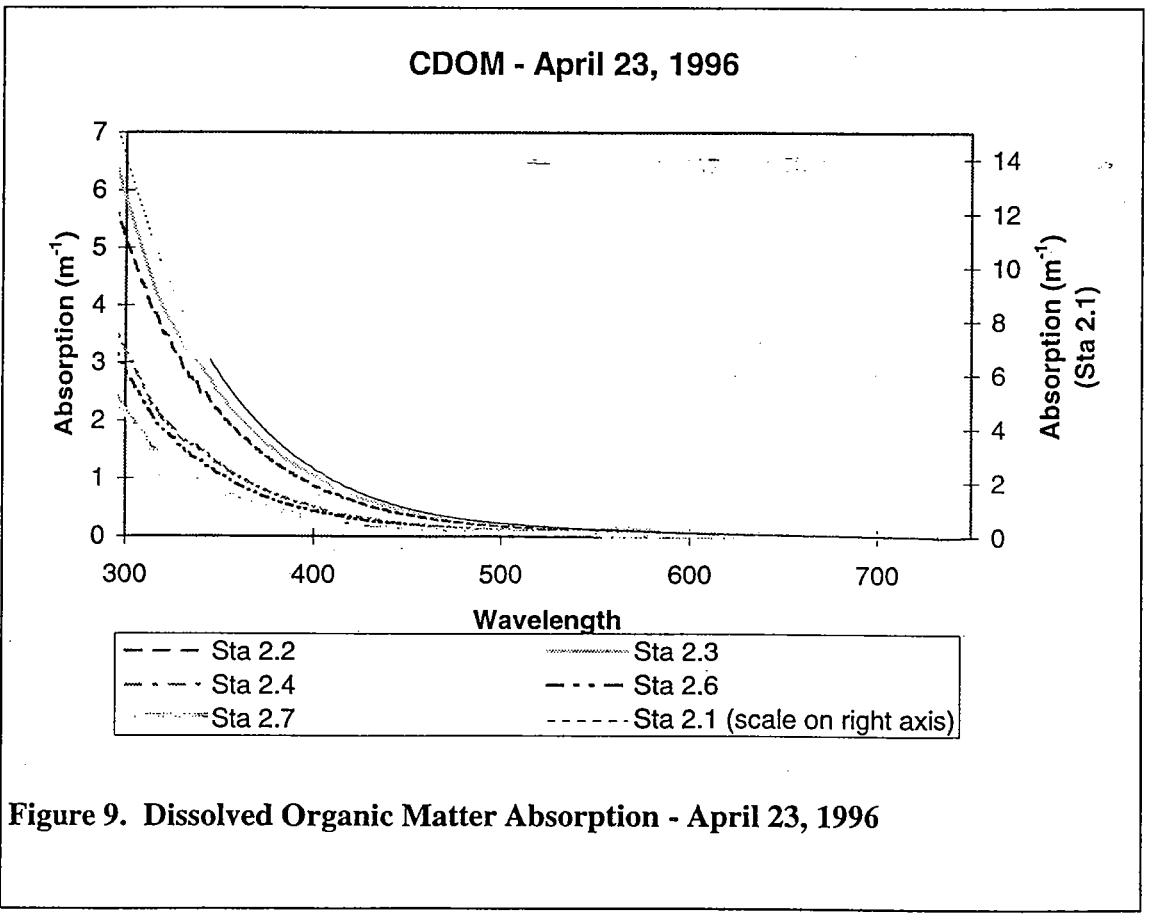
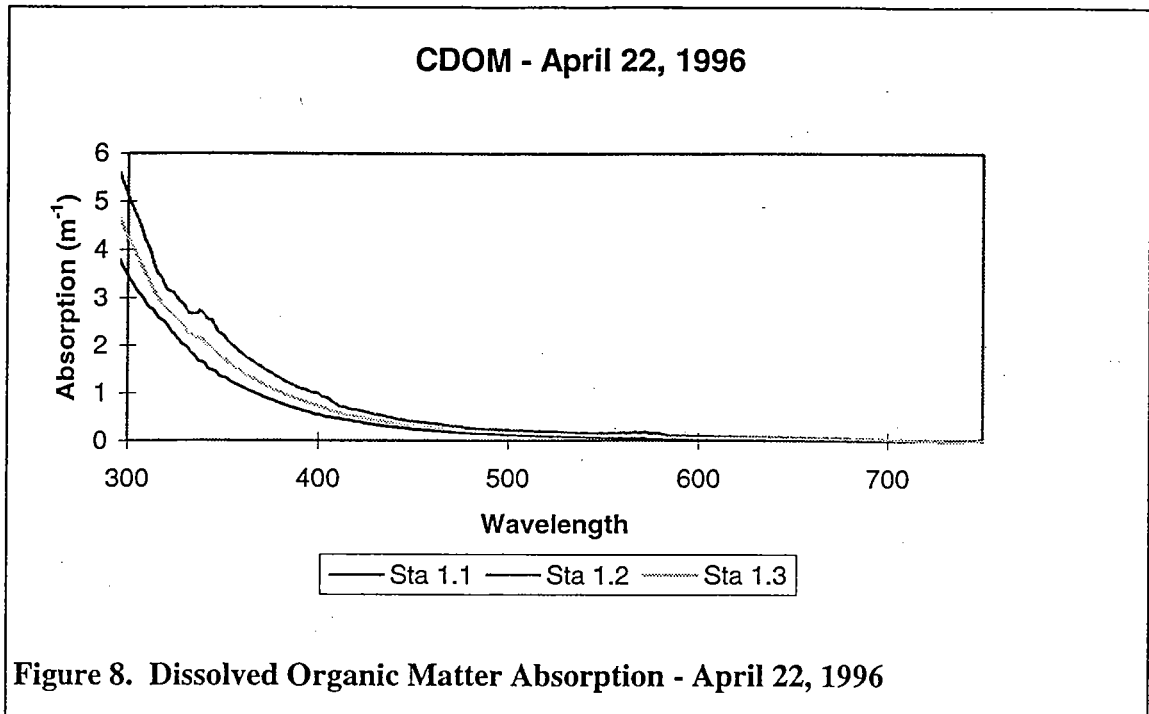

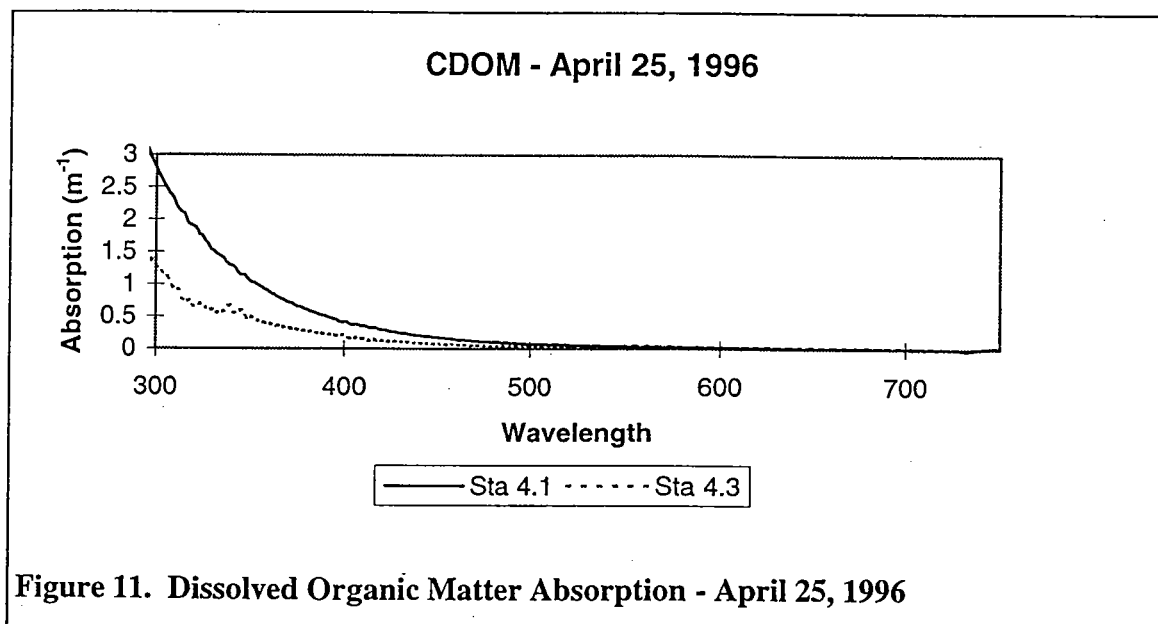
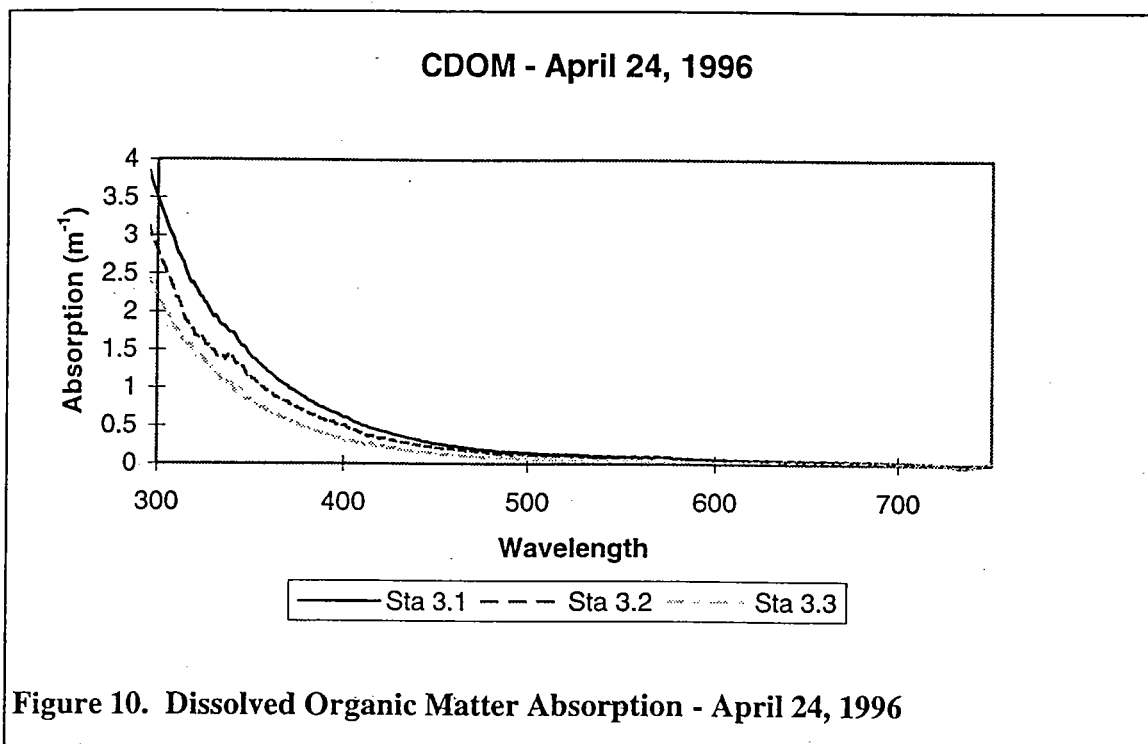

B. Optical Data

The profiles of light, temperature, scattering, fluorescence, and beam transmission are shown in Figures A1-A32 (Appendix A). Many of the optical casts (stations 2.1, 2.2 downcast, 2.4 upcast, 2.5 upcast, 2.6 downcast, 2.7, 3.1 downcast, and 3.2 upcast) appear to be compromised by ship shadow, presumably because the "A-frame" used to lower the PRR cage extended only 1-meter off the side of the ship. Due to rough weather, the PRR cage was often rapidly lowered to a depth of about 2 meters, to prevent the cage from banging against the side of the ship. This action reduced the data density near surface; therefore, some of the estimates of the sub-surface light field are not valid (stations 1.1 downcast, 2.3 upcast, 2.4 downcast, 2.5 downcast, 2.6 downcast, 3.1 downcast, 3.2 downcast, 3.3, 4.1 downcast, 4.2, and 4.3). Also highly attenuating waters of the inshore stations did not allow a valid calculation of the sub-surface light field (e.g. station 2.1). Upwelling radiance profiles from the mid-shelf stations (3.2, 4.2, and 4.3) show evidence of bottom reflection. The statistics for the calculation of the sub-surface light field are given in Appendix B.

V. Summary

This study further demonstrates the existence of a coastal front that separates the turbid inshore waters from the clearer mid-shelf waters discussed by Nelson and Guarda (1995). The particulate and dissolved organic matter absorption spectra can be used to delineate between the inshore stations and the mid-shelf ones. This coastal front runs very close to the boundaries of the GRNMS – stations 2.5, 3.3, 4.1, and 4.2 are within the GRNMS boundaries – and it is possible that at certain times of the year with high river out flow, terrestrially influenced waters will affect the visibility and water quality in the GRNMS.

VI. References

Cleveland, J. S. and A. D. Weidemann (1993). "Quantifying absorption by aquatic particles: A multiple scattering correcting for glass fiber filters." *Limnology and Oceanography* 38(6): 1321-1327.

Mitchell, B. G. (1990). "Algorithms for determining the absorption coefficient of aquatic particulates using the Quantitative Filter Technique (QFT)." *Ocean Optics X*, Orlando, FL, SPIE.

Mueller, J. L. and R. W. Austin (1995). Ocean Optics Protocols for SeaWiFS Validation, Revision 1. *SeaWiFS Technical Report Series, Vol. 25*. Eds: Hooker, S.B. and Firestone, E. R. 66 pp.

Nelson, J. R. and S. Guarda (1995). "Particulate and dissolved spectral absorption on the continental shelf of the southeastern United States." *Journal of Geophysical Research* 100(C5): 8715-8732.

Siegel, D. A., M. C. O'Brien, J. C. Sorensen, D. A. Konnoff and E. Fields (1995). "BBOP Data Processing and Sampling Procedures." Vol: 19, Institute for Computational Earth System Science, UC Santa Barbara, Santa Barbara, CA, 23 pp.

Welschmeyer, N. (1994). "Fluorometric analysis of chlorophyll *a* in the presence of chlorophyll *b* and pheopigments." *Limnology and Oceanography* 39(8): 1985-1992.

Wright, S. W., S. W. Jeffrey, R. F. C. Mantoura, C. A. Llewellyn, T. Bjornland, D. Repeta and N. A. Welschmeyer (1991). "Improved HPLC method for the analysis of chlorophylls and carotenoids from marine phytoplankton." *Marine Ecology Progress Series* 77: 183-196.

VII. Metadata

The metadata, including points of contact, parameters measured, and measurement methods for the cruise are given below.

A. Core Documentation

Identification_Information

Citation

Citation_Information

Originator: National Oceanic and Atmospheric Administration Coastal Services Center

Publication_Date: 1997

Title: NOAA CSC/CRS Cruise APR96FER: Gray's Reef Cruise

Online Linkage: <http://www.csc.noaa.gov/crs/cruises/apr96fer/index.html>

Description

Abstract: The Gray's Reef National Marine Sanctuary (GRNMS) is one of the most popular recreational fishing and diving areas off the Georgia Coast. Thus primary production - the production rate of phytoplankton, the bottom of the food chain - and the water quality of this region are of great interest to sanctuary managers. These parameters impact fish populations and recreational diving. Ocean color satellites provide daily synoptic data of the region and could be a useful tool to sanctuary managers. However, for this tool to be truly useful, algorithms that relate satellite data to chlorophyll biomass, primary production, and water column visibility need to be developed and validated.

Measurements of surface chlorophyll pigment biomass, particulate absorption, dissolved organic material absorption, and spectral fluorescence were made during a cruise from April 22 to 25, 1996 in the vicinity of Gray's Reef National Marine Sanctuary. Water column profiles of temperature, conductivity, salinity, chlorophyll fluorescence, scattering, beam transmittance, upwelling radiance and downwelling irradiance were made at 16 stations.

Purpose: The objective of this cruise was to determine the optical properties and variability within GRNMS and the surrounding area.

Supplemental_Information:

StartDate: 19962204

StopDate: 19962504

Preview: <http://www.csc.noaa.gov/crs/cruises/index.html>

Time_Period_of_Content
Time_Period_Information
Single_Date/Time
Calendar_Date: 1996
Currentness_Reference: Publication Date

Status
Progress: Complete
Maintenance_and_Update_Frequency: Unknown

Spatial Domain
Bounding Coordinates:
West Bounding Coordinate: -81.24
East Bounding Coordinate: -80.45
North Bounding Coordinate: 31.97
South Bounding Coordinate: 31.33

Keywords

Theme

Theme_Keyword_Thesaurus: None
Theme_Keyword: oceanography
Theme_Keyword: bio-optical
Theme_Keyword: turbidity
Theme_Keyword: water clarity
Theme_Keyword: blooms
Theme_Keyword: resuspension
Theme_Keyword: spatial variability
Theme_Keyword: river plumes
Theme_Keyword: coastal water optics
Theme_Keyword: case II algorithms
Theme_Keyword: absorption
Theme_Keyword: attenuation
Theme_Keyword: AVHRR
Theme_Keyword: reflectance difference
Theme_Keyword: in-situ optical profiling
Theme_Keyword: ocean color satellites
Theme_Keyword: coastal ocean algorithm development

Place

Place_Keyword_Thesaurus: None
Place_Keyword: Gray's Reef National Marine Sanctuary
Place_Keyword: Sapelo Sound
Place_Keyword: Georgia Bight

Place_Keyword: South Atlantic Bight

Place_Keyword: Georgia

Place_Keyword: United States

Time

Temporal_Keyword: Spring freshet

Temporal_Keyword: April, 1996

Parameters Measured

Parameter_Keyword: spectral downwelling irradiance

Parameter_Keyword: spectral upwelling radiance

Parameter_Keyword: temperature

Parameter_Keyword: chlorophyll concentration

Parameter_Keyword: phytoplankton pigment concentration

Parameter_Keyword: particulate absorption

Parameter_Keyword: dissolved organic matter absorption

Parameter_Keyword: salinity

Parameter_Keyword: spectral fluorescence

Parameter_Keyword: particulate organic nitrogen concentration

Parameter_Keyword: particulate organic carbon concentration

Parameter_Keyword: beam attenuation at 660 nm

Parameter_Keyword: *in-situ* fluorescence

Parameter_Keyword: scalar quantum irradiance

Parameter_Keyword: light scattering

Point_of_Contact:

Contact_Information:

Contact_Organization_Primary:

Contact_Organization: NOAA Coastal Services Center

Contact_Person: Dr. A. Subramaniam

Contact_Address:

Address_Type: mailing and physical

Address: 2234 Hobson Avenue

City: Charleston

State: South Carolina

Postal_Code: 29405-2413

Country: USA

Contact_Voice_Telephone: (800)789-2234

Contact_Electronic_Mail_Address: crs@csc.noaa.gov

Hours_of_Service: 8AM-5PM, M-F

B. Citation Information

Source Citation: Subramaniam, A., K.J. Waters, A.W. Meredith, E.M. Armstrong, R.M. Bohne, W.G. Keull, J.R. Nelson, G.R. DiTullio, and J.C. Brock. 1997. NOAA CSC/CRS Cruise APR96FER: Gray's Reef Cruise. CSC Technical Report CSC/7-97/001. NOAA Coastal Services Center. Charleston, SC. Pp38.

Currentness: July 1997

Access Constraints: None

Use Constraints: This data was acquired for scientific research and is applicable for algorithm validation purposes. Knowledge of in-water optics is expected of users for interpretation of the data. Users of this data are required to provide appropriate attribution in the form of co-authorship for any publications that use this data, unless formal permission to do otherwise is granted by NOAA/CSC.

C. Data Quality

Process Description: See Methods, page 1

Spectroradiometer measurements: Spectral downwelling irradiance (*in-situ* and above surface), spectral upwelling radiance, temperature

Instruments: PRR600s, PRR610
Manufacturer: Biospherical Instruments, Inc.
Address: 5340 Riley Street
San Diego, CA 92110-2621
Phone: (619) 686.1888

Beam attenuation: C660
Instrument: SeaTech transmissometer
Manufacturer: Sea Tech, Inc.
Address: 825 NE Circle Blvd.
Corvallis, OR 97330
Phone: (206) 757-9716

Fluorescence: Fluorometer
Instrument: WetStar fluorometer
Manufacturer: WET Labs, Inc
Address: 620 Applegate Street
Philomath, OR 97370
Phone: (541) 929-5650

Light scattering
Instrument: SeaTech LSS
Manufacturer: Sea Tech, Inc.
Address: 825 NE Circle Blvd.
Corvallis, OR 97330
Phone: (206) 757-9716

Quantum scalar irradiance.

Instrument: QSP200
Manufacturer: Biospherical Instruments, Inc.
Address: 5340 Riley Street
San Diego, CA 92110-2621
Phone: (619) 686.1888

Spectral fluorescence

Instrument: WetLabs SAFire
Manufacturer: WET Labs, Inc
Address: 620 Applegate Street
Philomath, OR 97370
Phone: (541) 929-5650

GPS position and time

Instrument: Unknown
Manufacturer: Unknown

Surface temperature, salinity.

Instrument: Hydrolabs Datasonde-3
Manufacturer: Hydrolab Corporation
P.O. Box 50116
Austin, TX 78763
Phone: 1-800-949-3766

Operator: Kirk Waters
Address: see point of contact

Chlorophyll measurements:

Methods reference: Welschmeyer, N. (1994). "Fluorometric analysis of chlorophyll *a* in the presence of chlorophyll *b* and pheopigments." *Limnology and Oceanography* 39(8): 1985-1992.

Phytoplankton pigment measurements:

Methods reference: Wright, S. W., S. W. Jeffrey, R. F. C. Mantoura, C. A. Llewellyn, T. Bjornland, D. Repeta and N. A. Welschmeyer (1991). "Improved HPLC method for the analysis of chlorophylls and carotenoids from marine phytoplankton." *Marine Ecology Progress Series* 77: 183-196.

Analyst: Mark Geesey
Address: Grice Marine Biological Laboratory
205 Fort Johnson Road
Charleston, SC 29412
Telephone: (803) 406-4000.

Absorption measurements:

Methods reference: Nelson, J. R. and S. Guarda (1995). "Particulate and dissolved spectral absorption on the continental shelf of the southeastern United States." *Journal of Geophysical Research* 100(C5): 8715-8732.

Analysts: Jim Nelson
Address: Skidaway Institute of Oceanography
10 Ocean Science Circle
Savannah, GA 31411
Telephone: (912) 598-2687.

Attribute Accuracy: See Appendix D

Horizontal Positional Accuracy: 10 m

Entity and Attribute Overview Description: See Methods, page 1

D. Metadata Reference Information

Metadata Date: 25 July, 1997

Contact Organization: NOAA/Coastal Services Center

Contact Person: Lauren Parker

Full Address: see point of contact

Metadata Standard Name: Content Standards for Digital Geospatial Metadata Workbook.

Metadata Standard Version: Version 1.0

The core documentation section is designed for the purposes of the Coastal Information Directory (CID). The metadata in this section is used in building the CID's database.

VIII. Appendix A - Water Column Profile Data Figures

The following pages contain figures that show the *in-situ* water column profile data.

Figure A.1a - Station 1.1 Downcast

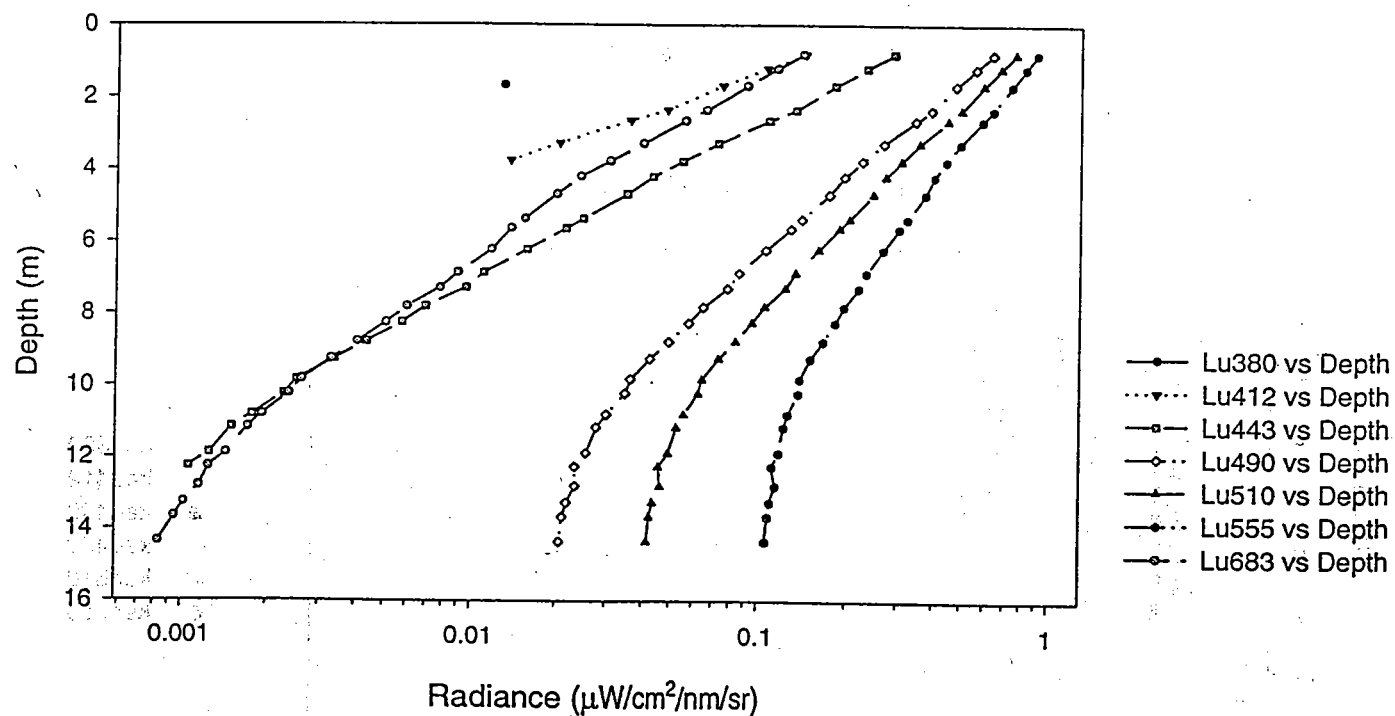
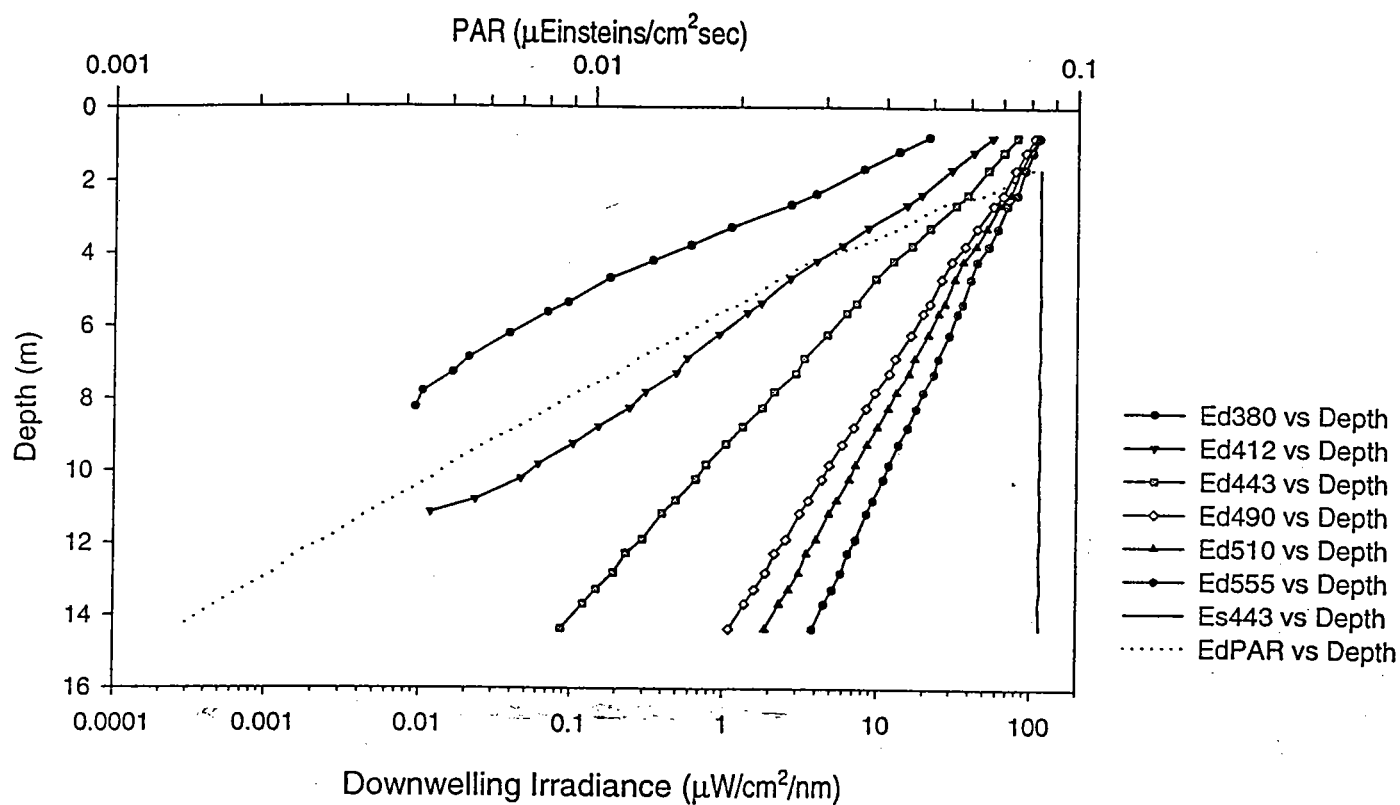
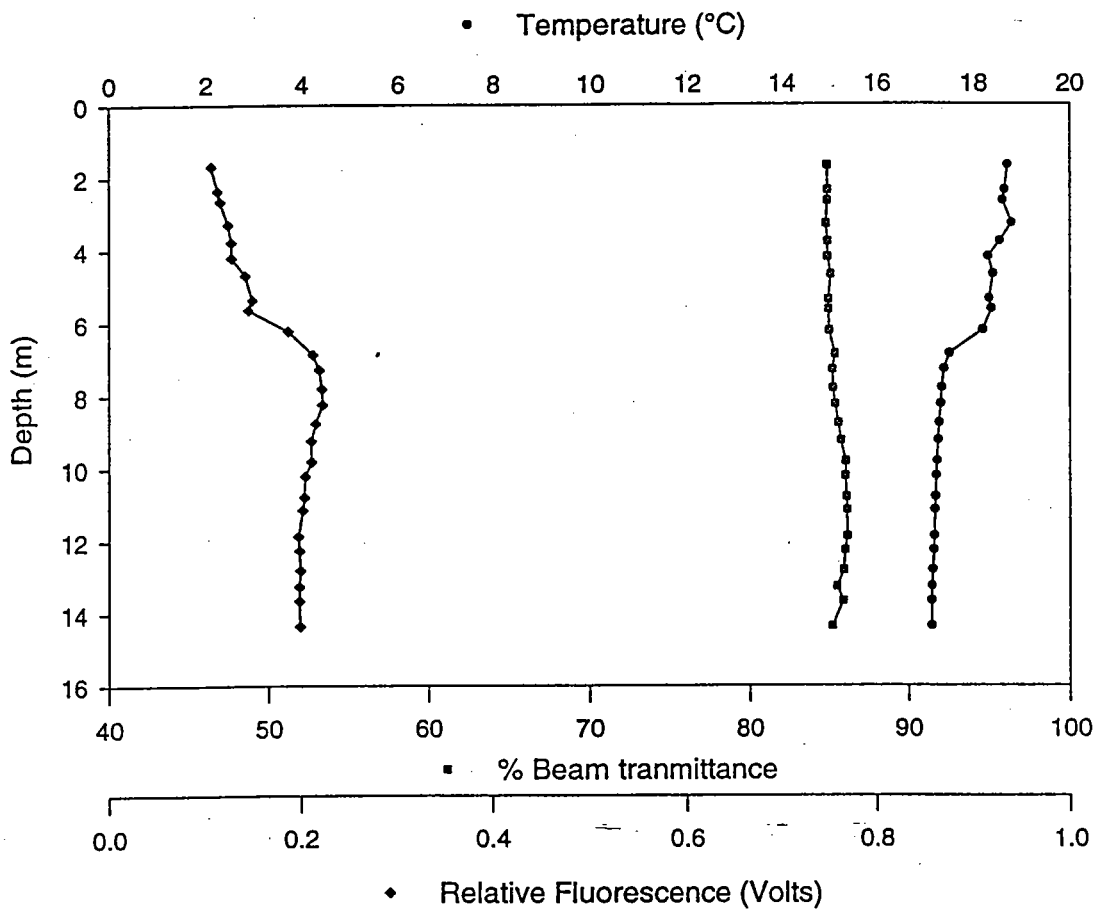

Figure A.1b - Station 1.1 Downcast



Diffuse Attenuation Coefficient ($k\lambda$)

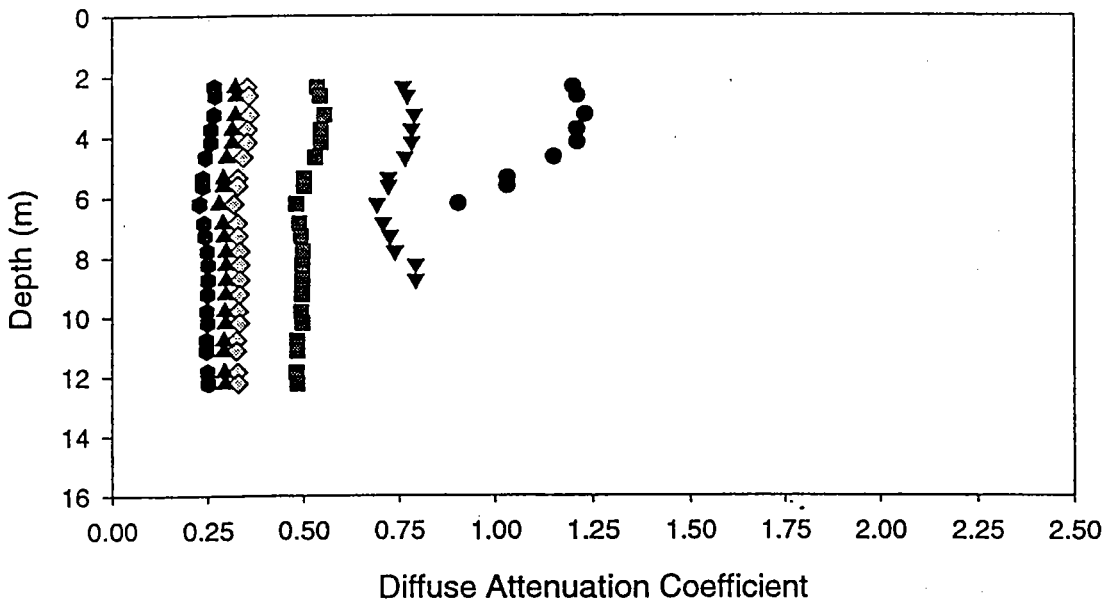

Figure A.2a - Station 1.1 Upcast

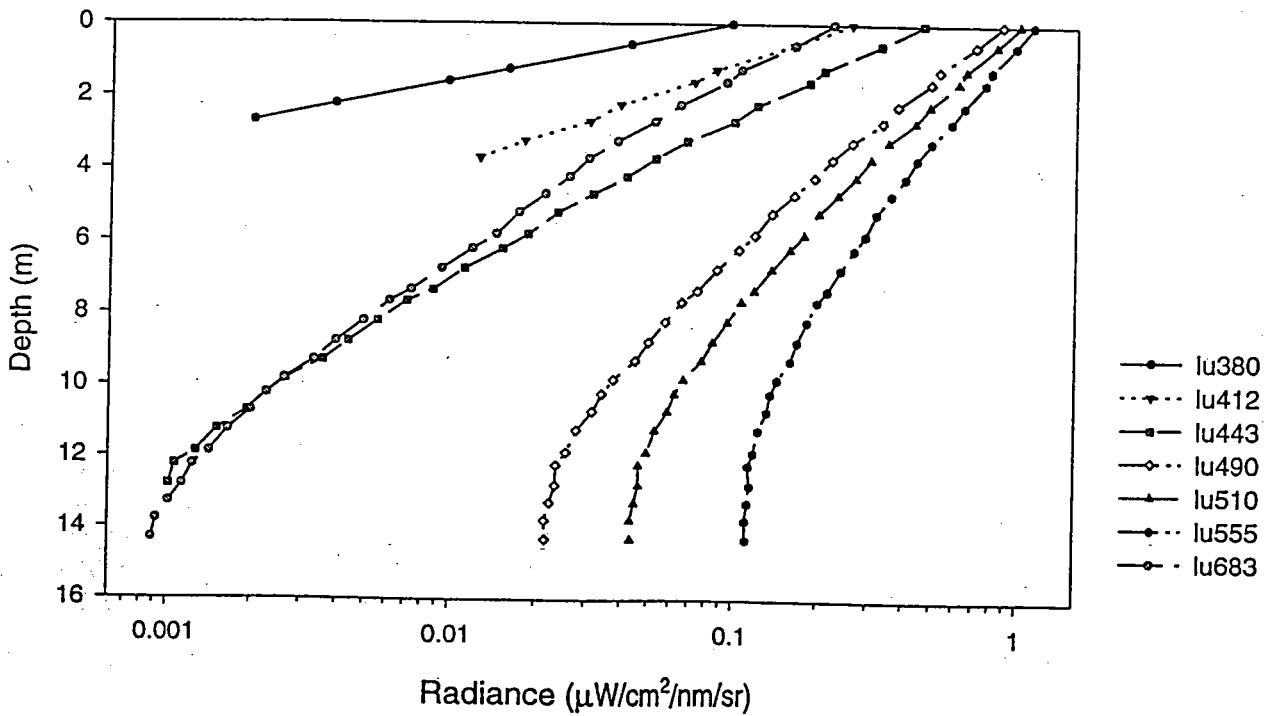
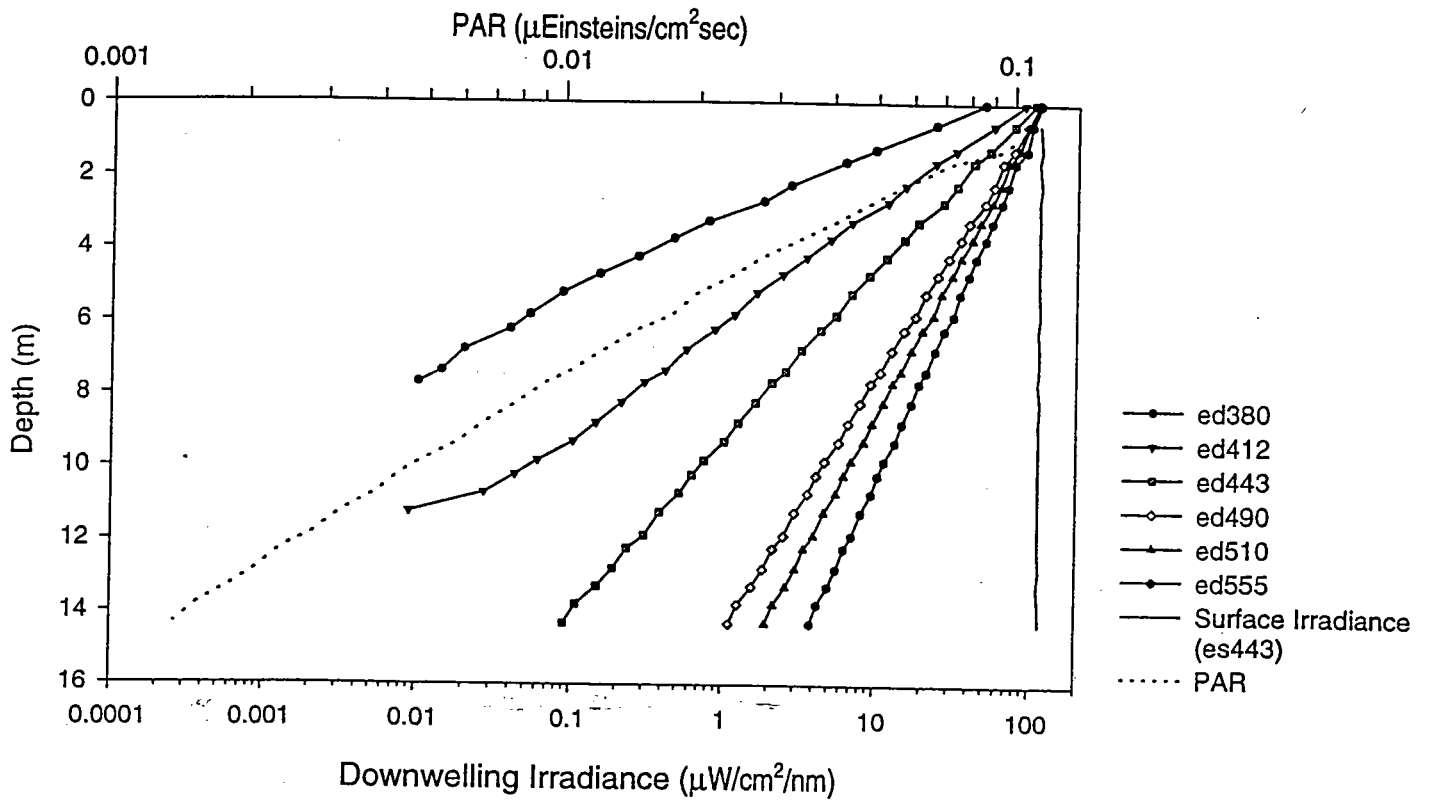
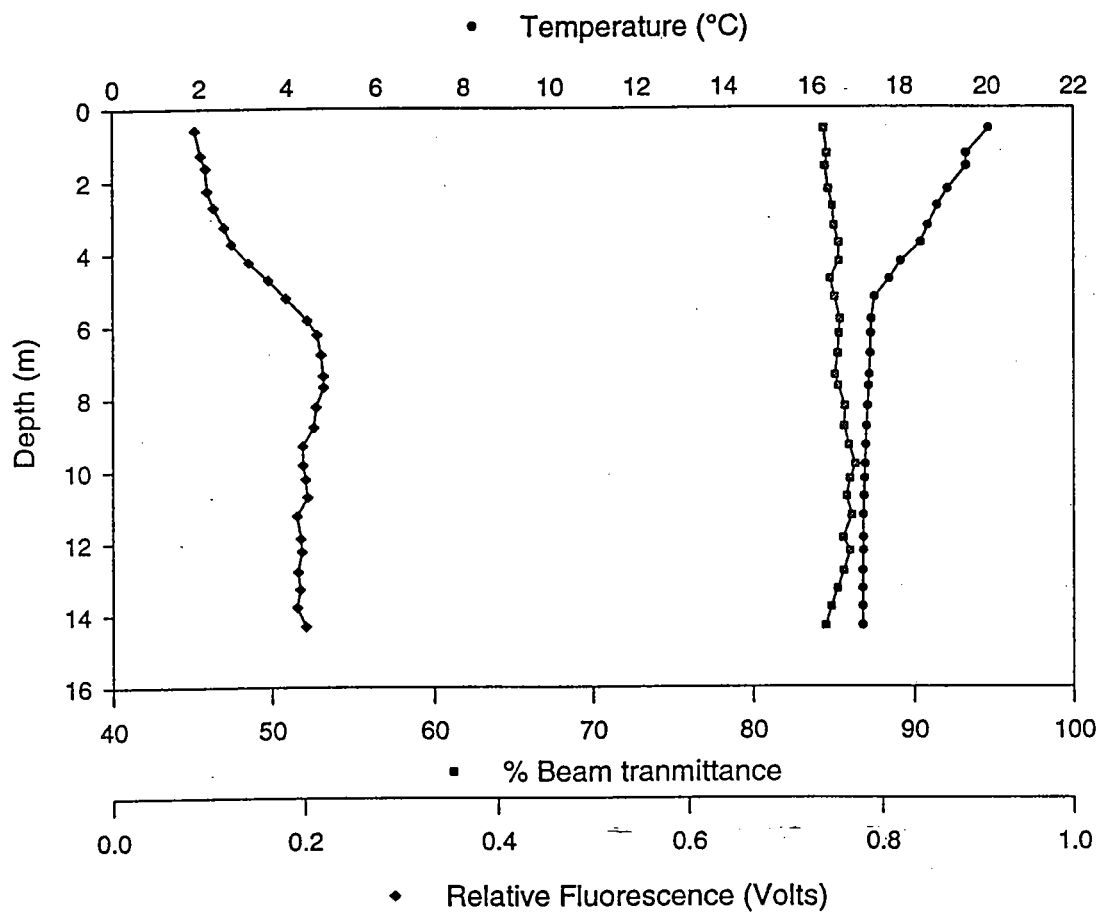

Figure A.2b - Station 1.1 Upcast



Diffuse Attenuation Coefficient ($k\lambda$)

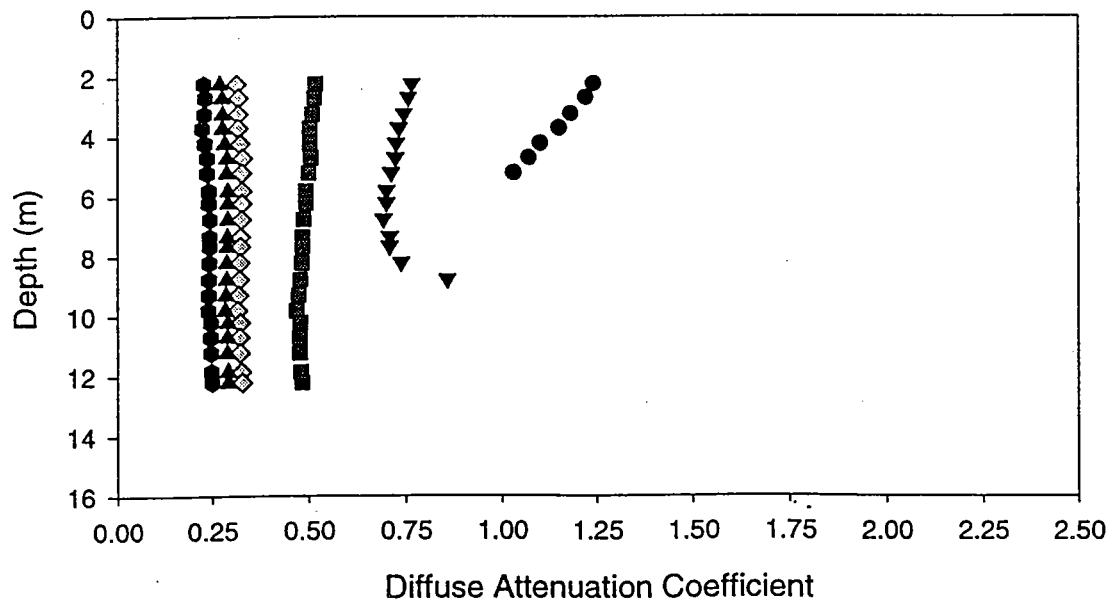

Figure A.3a - Station 1.2 Downcast

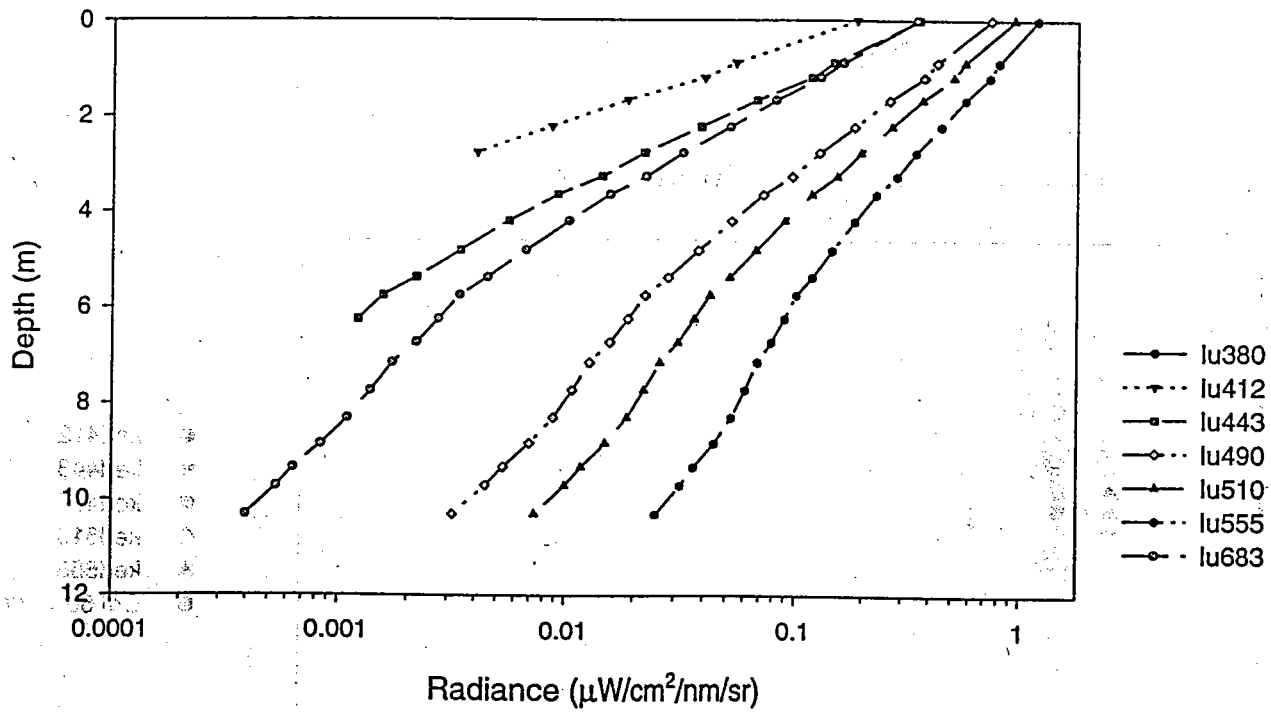
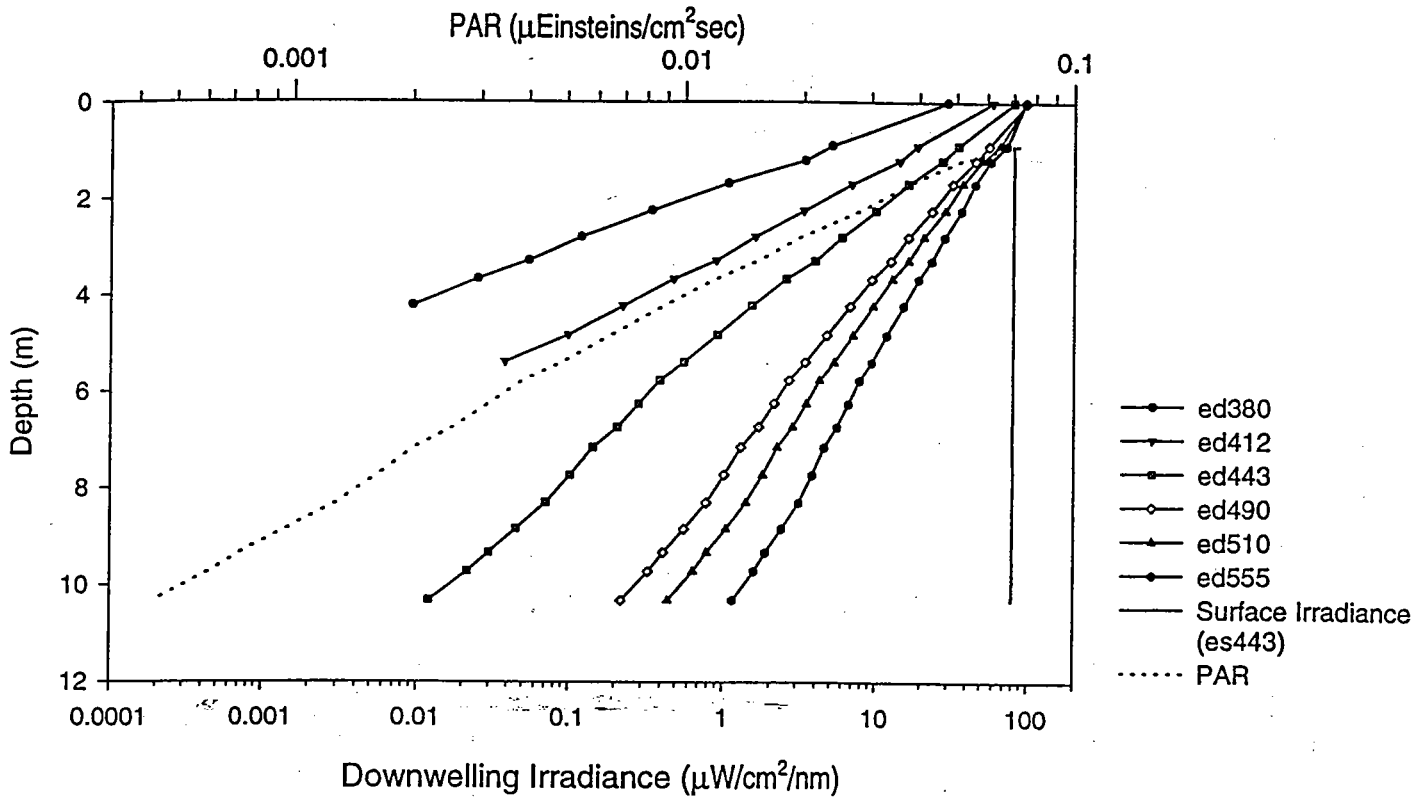
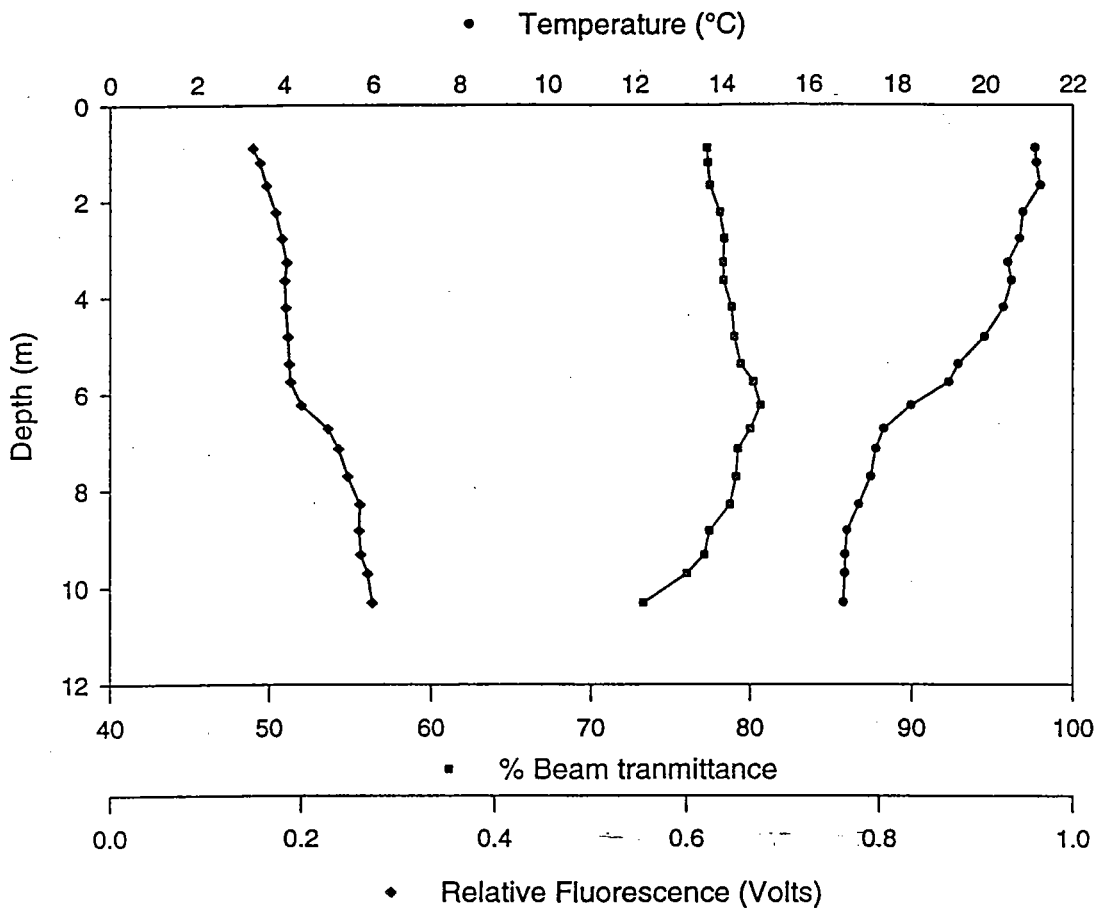

Figure A.3b - Station 1.2 Downcast



Diffuse Attenuation Coefficient ($k\lambda$)

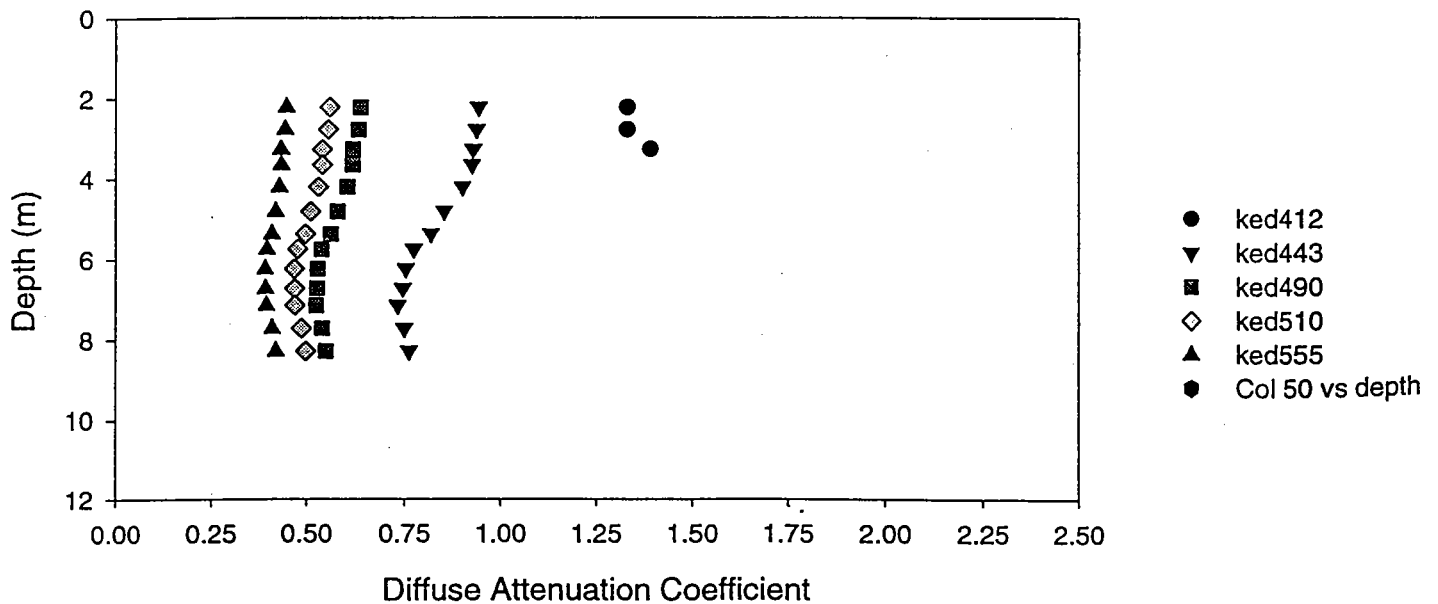

Figure A.4a - Station 1.2 Upcast

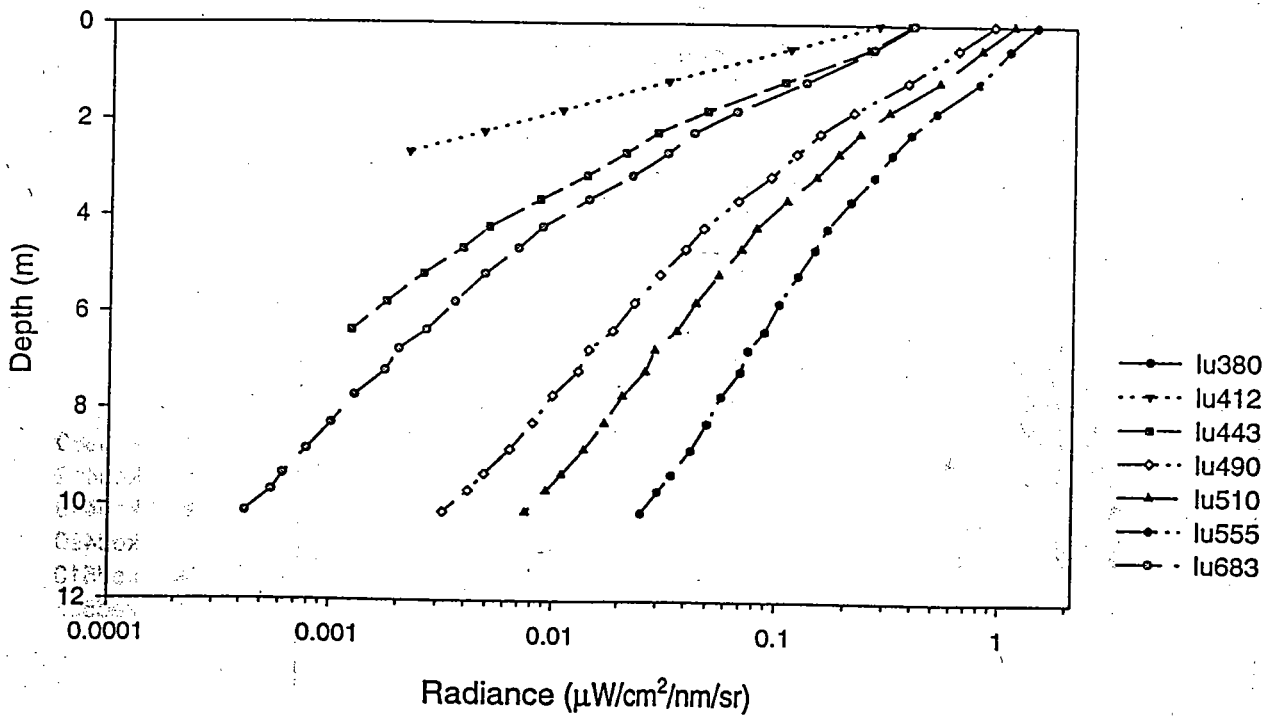
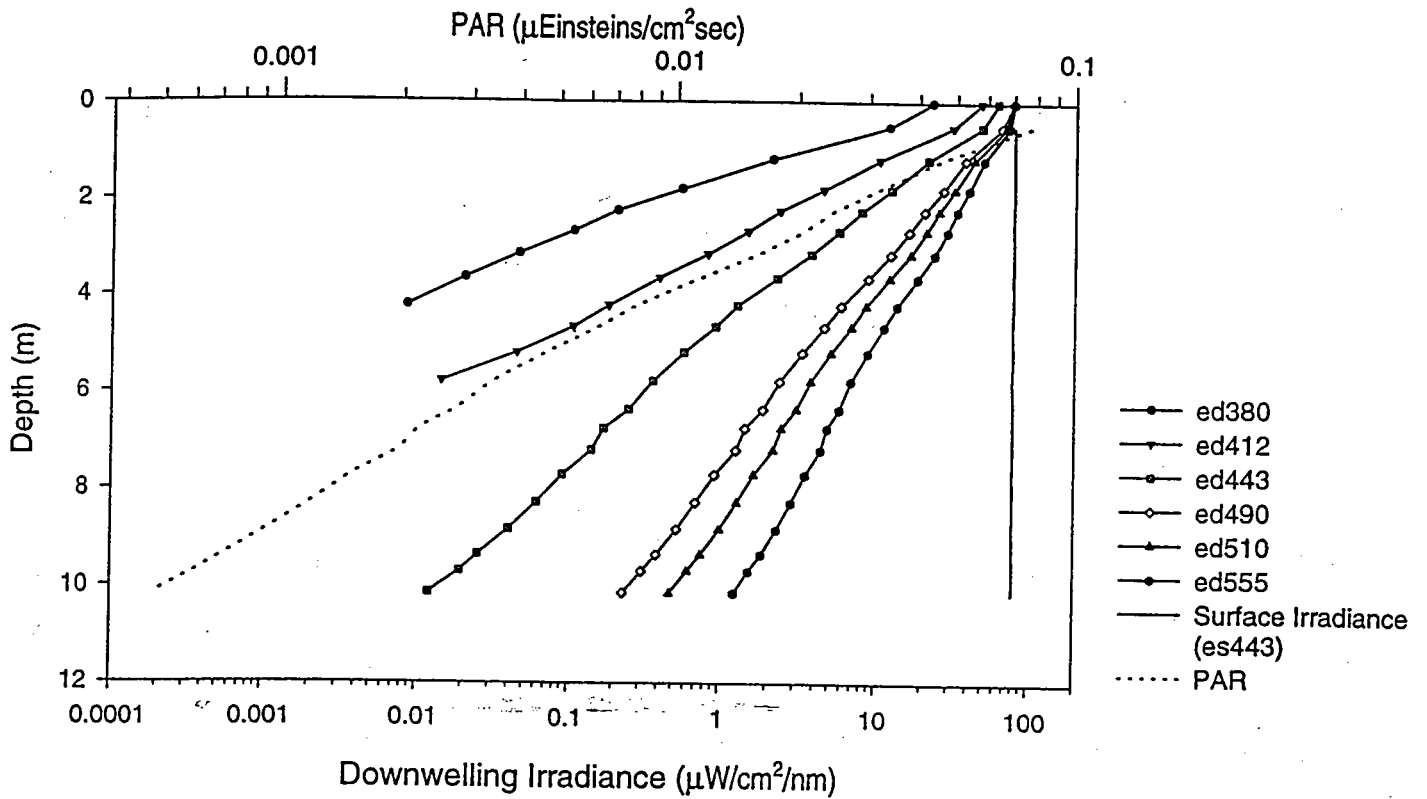
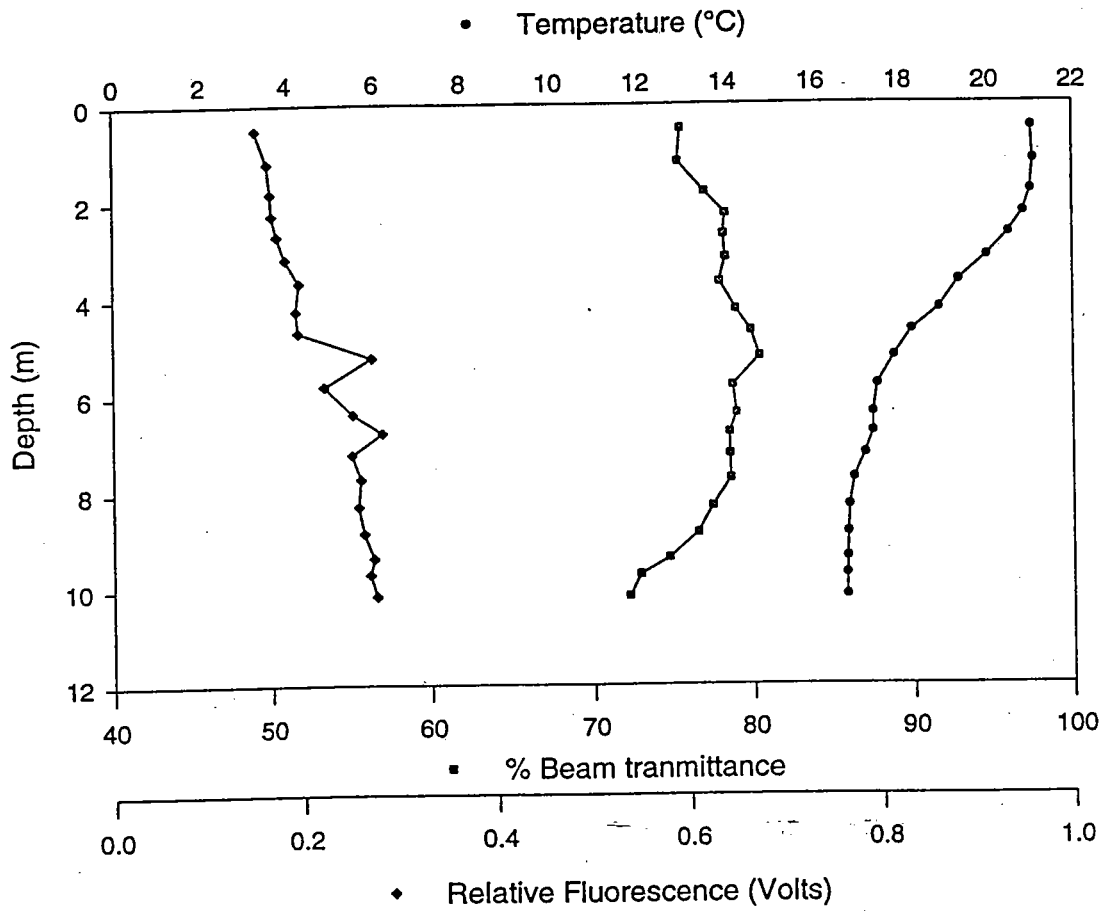

Figure A.4b - Station 1.2 Upcast



Diffuse Attenuation Coefficient ($k\lambda$)

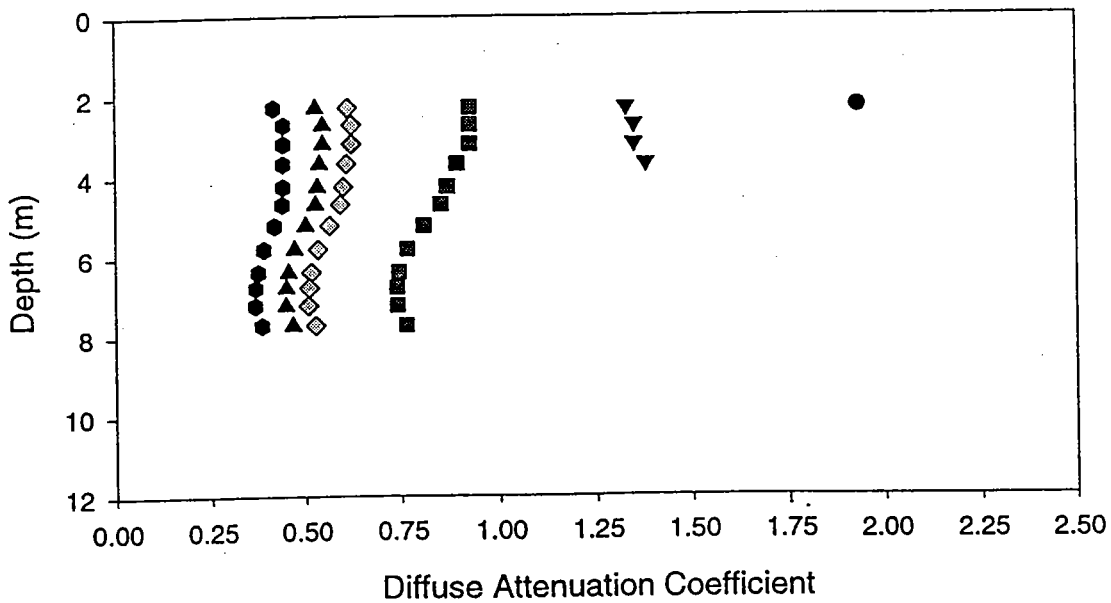

Figure A.5a - Station 1.3 Downcast

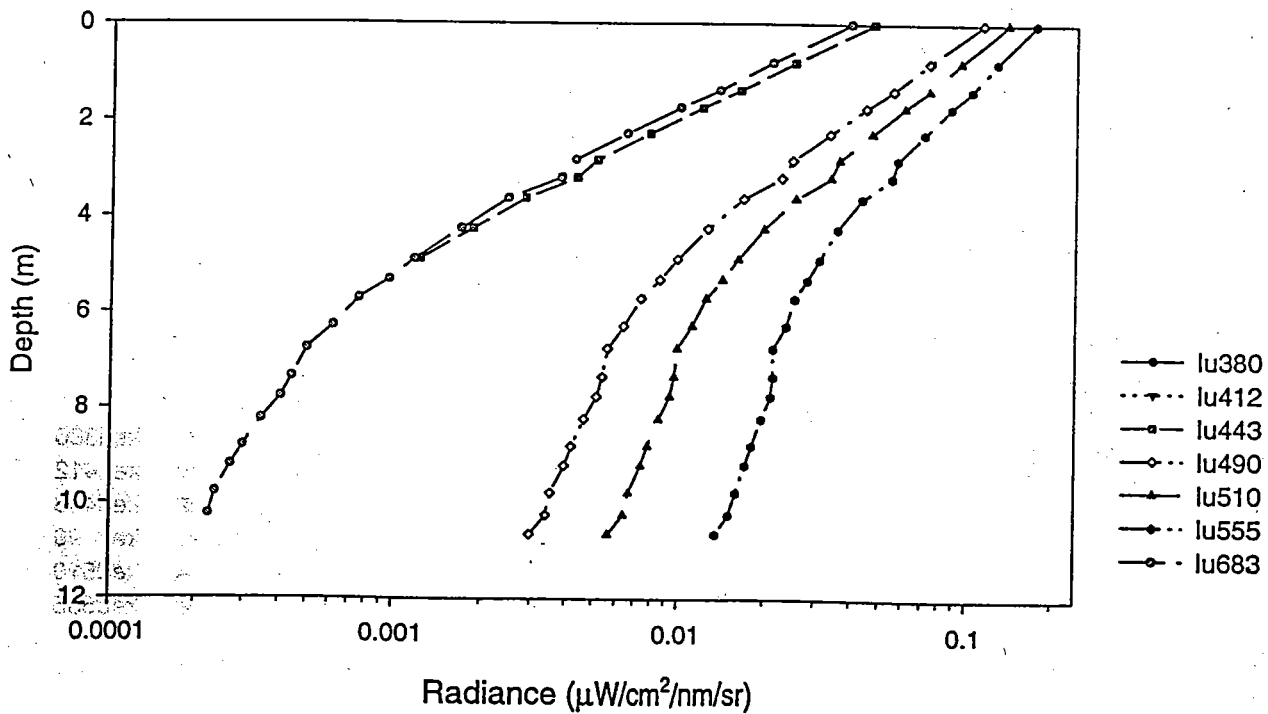
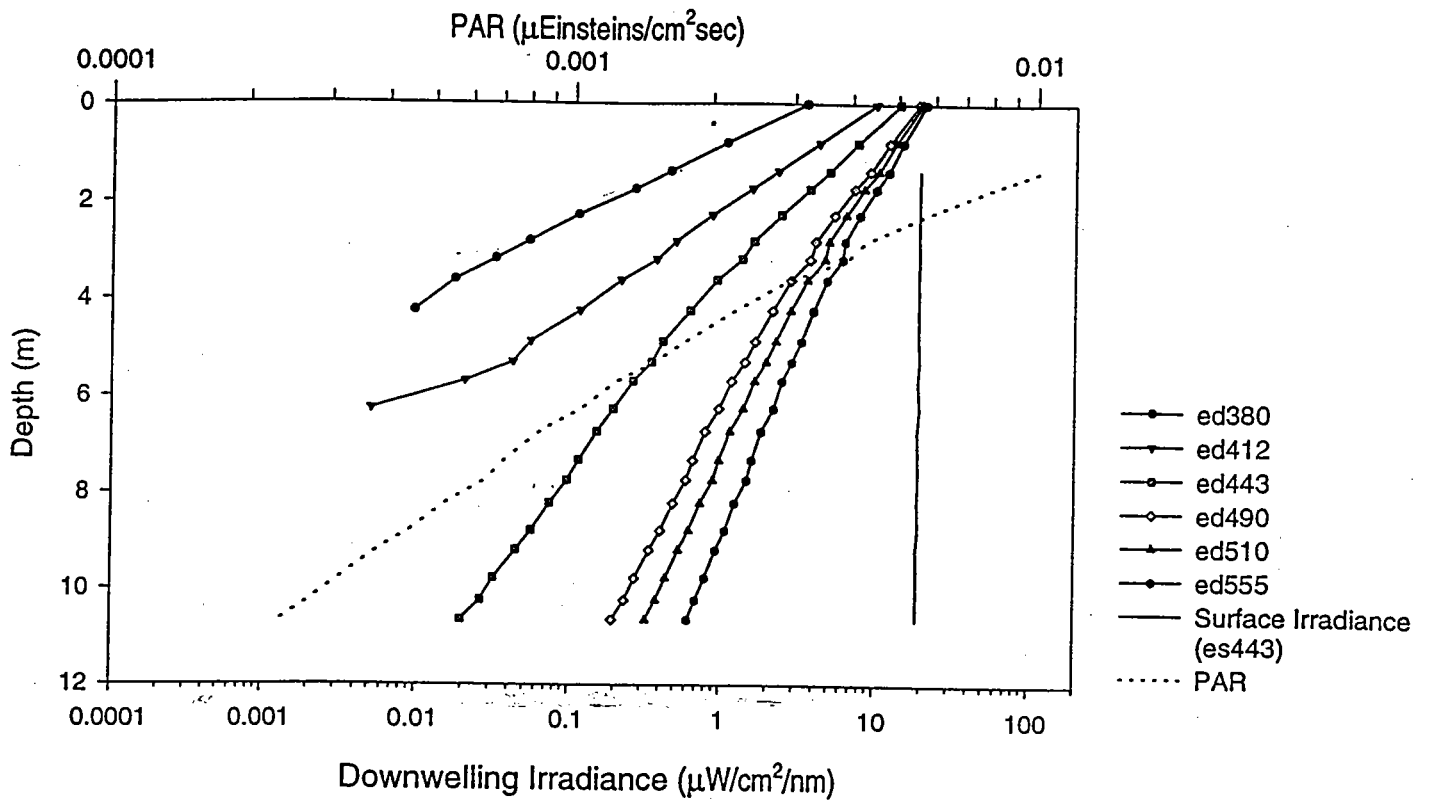
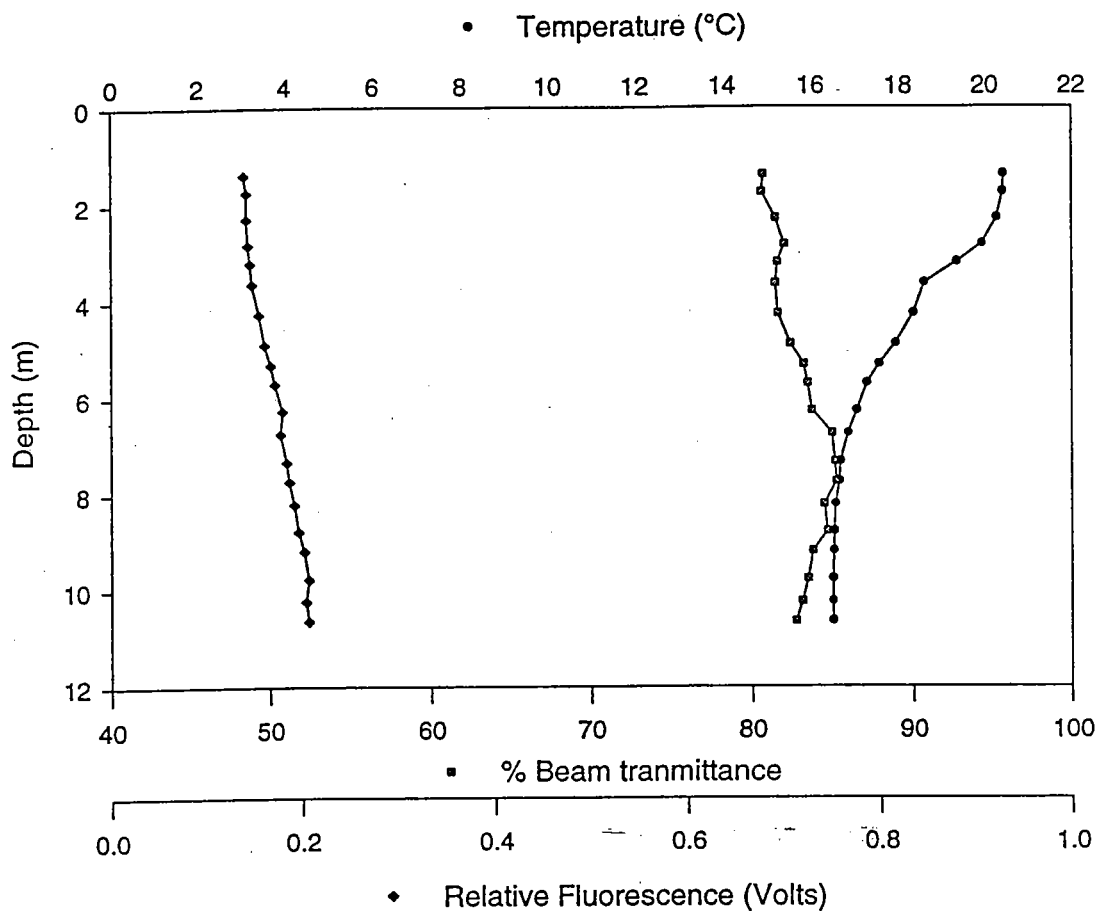

Figure A.5b - Station 1.3 Downcast



Diffuse Attenuation Coefficient ($k\lambda$)

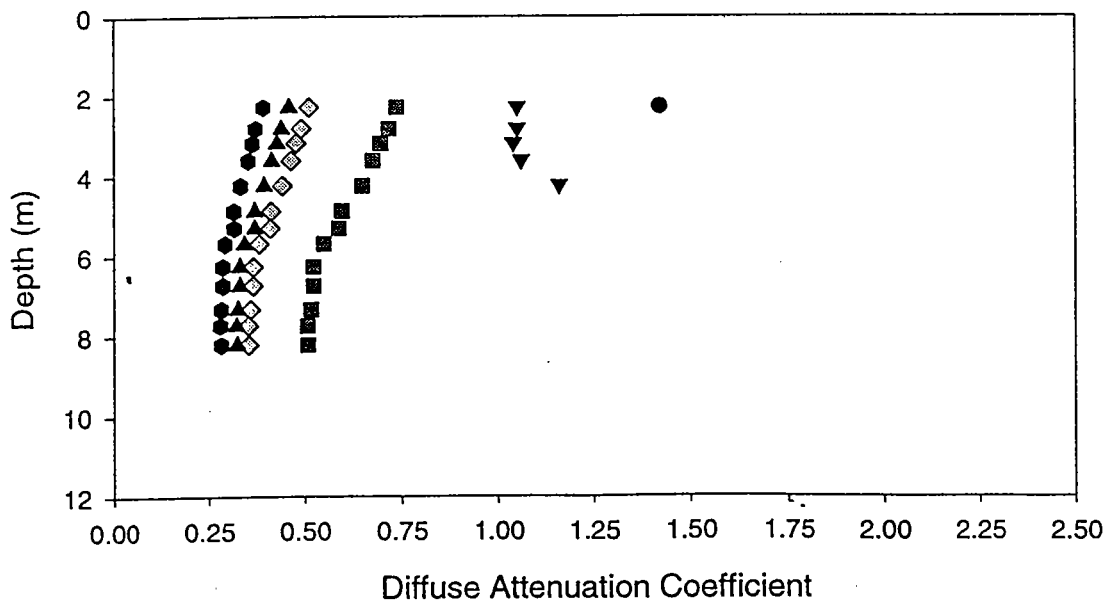

Figure A.6a - Station 1.3 Upcast

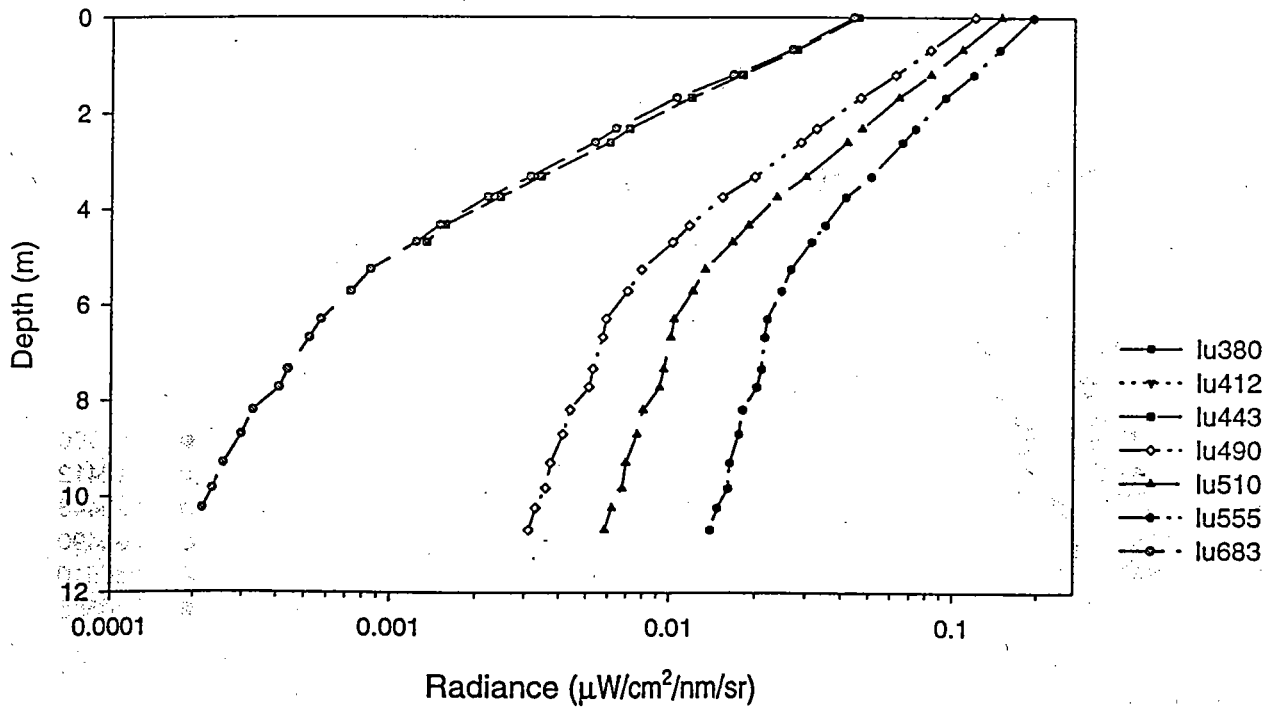
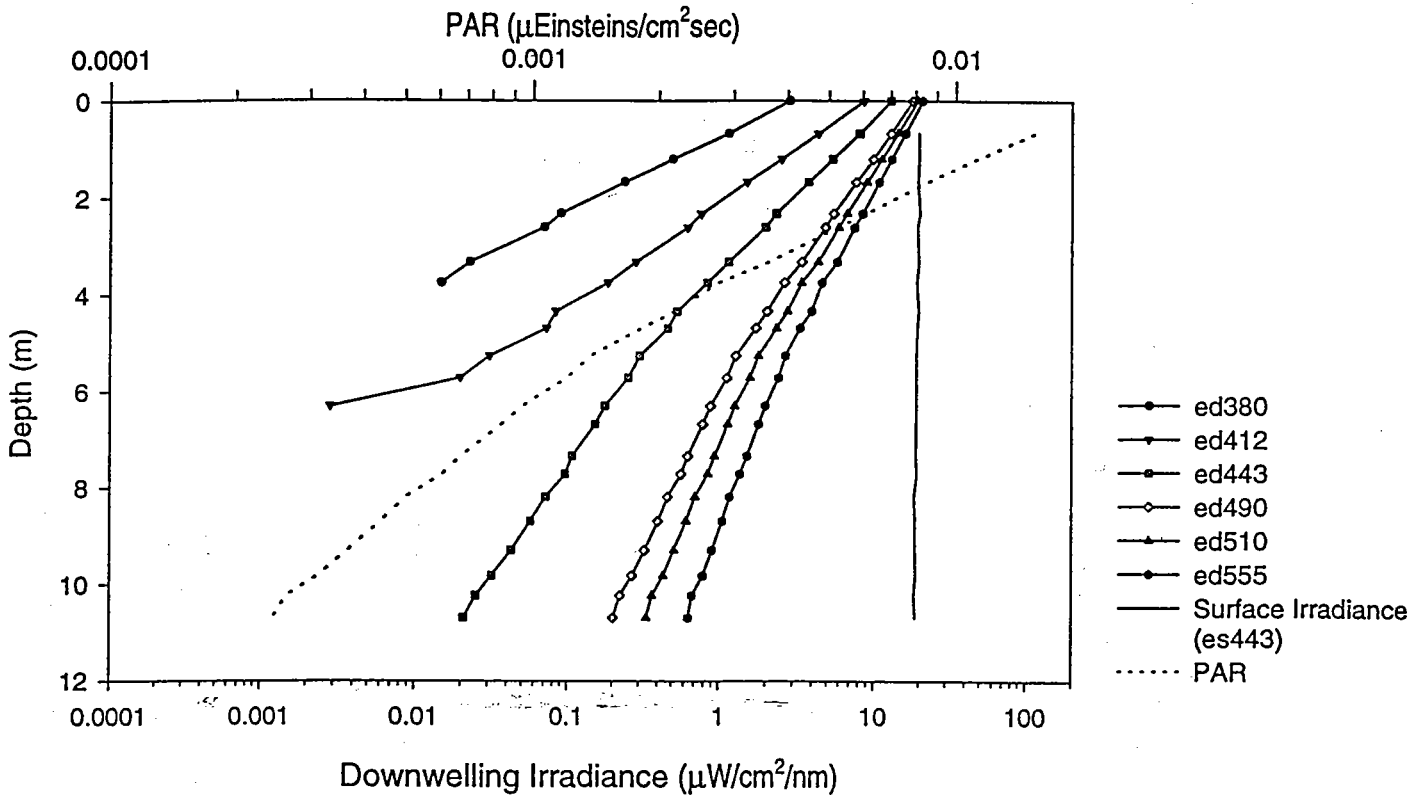
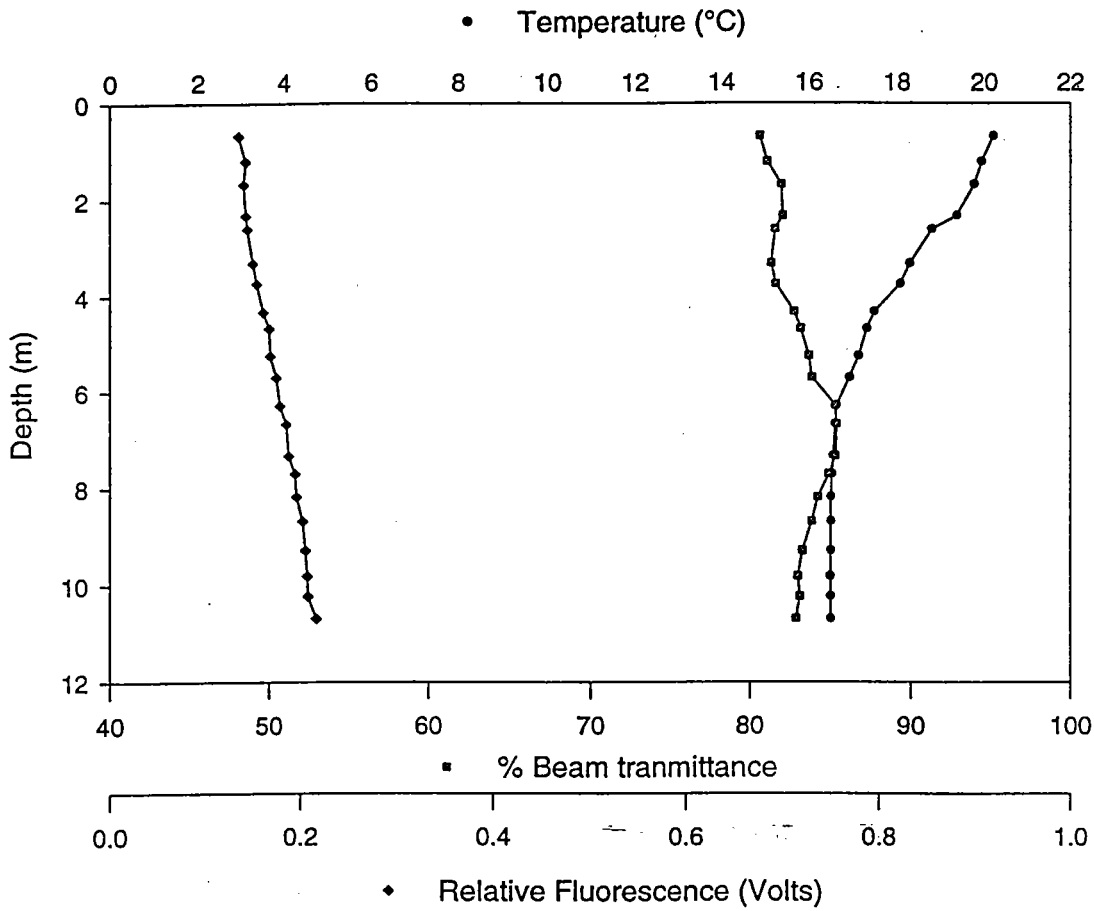

Figure A.6b - Station 1.3 Upcast



Diffuse Attenuation Coefficient ($k\lambda$)

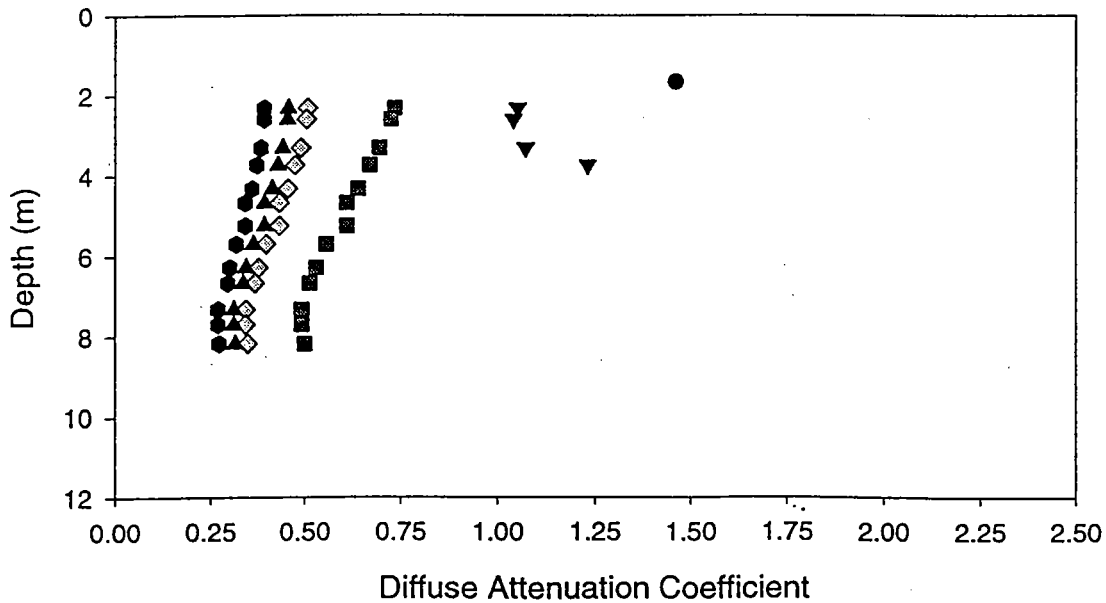

Figure A.7a - Station 2.1 Downcast

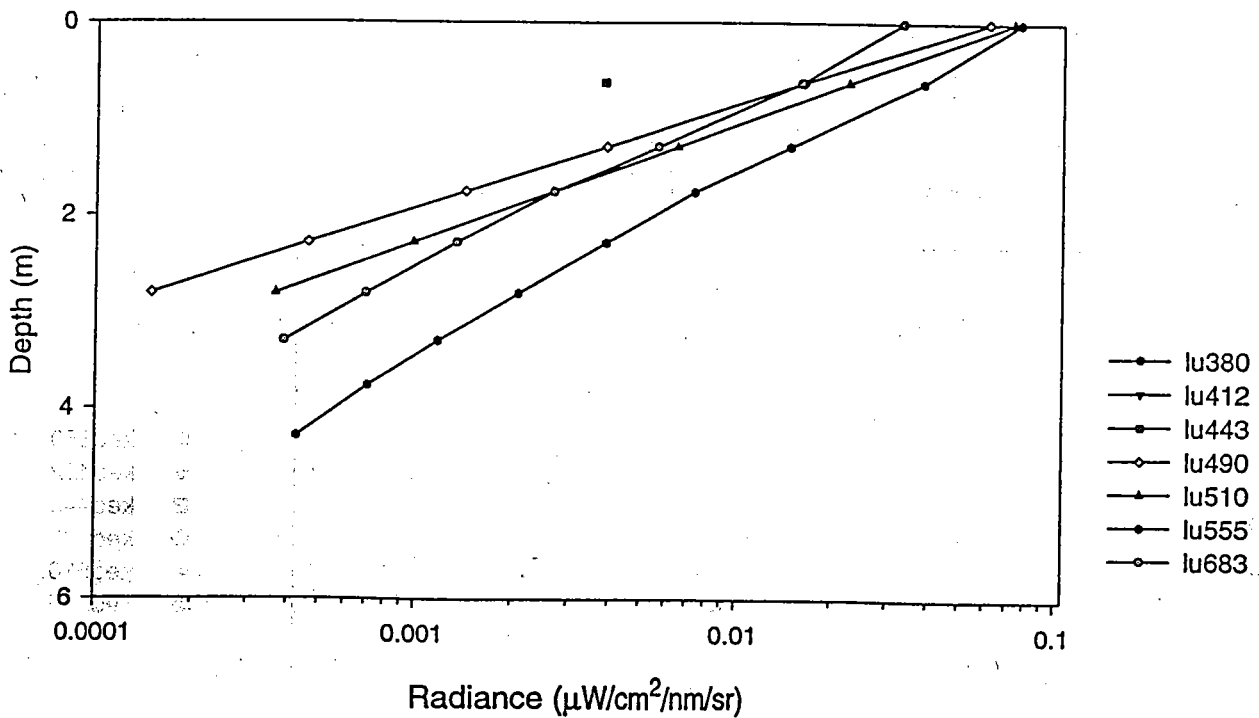
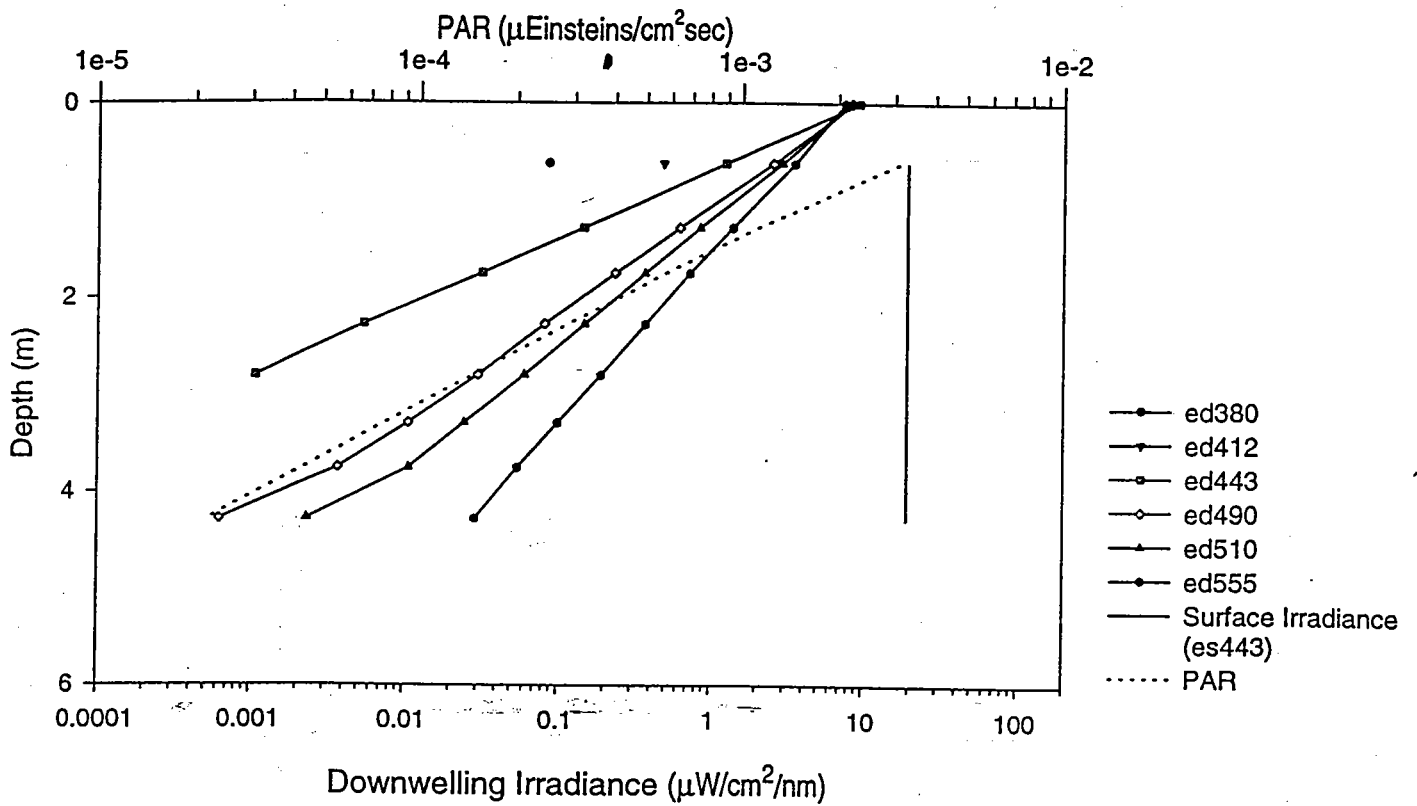
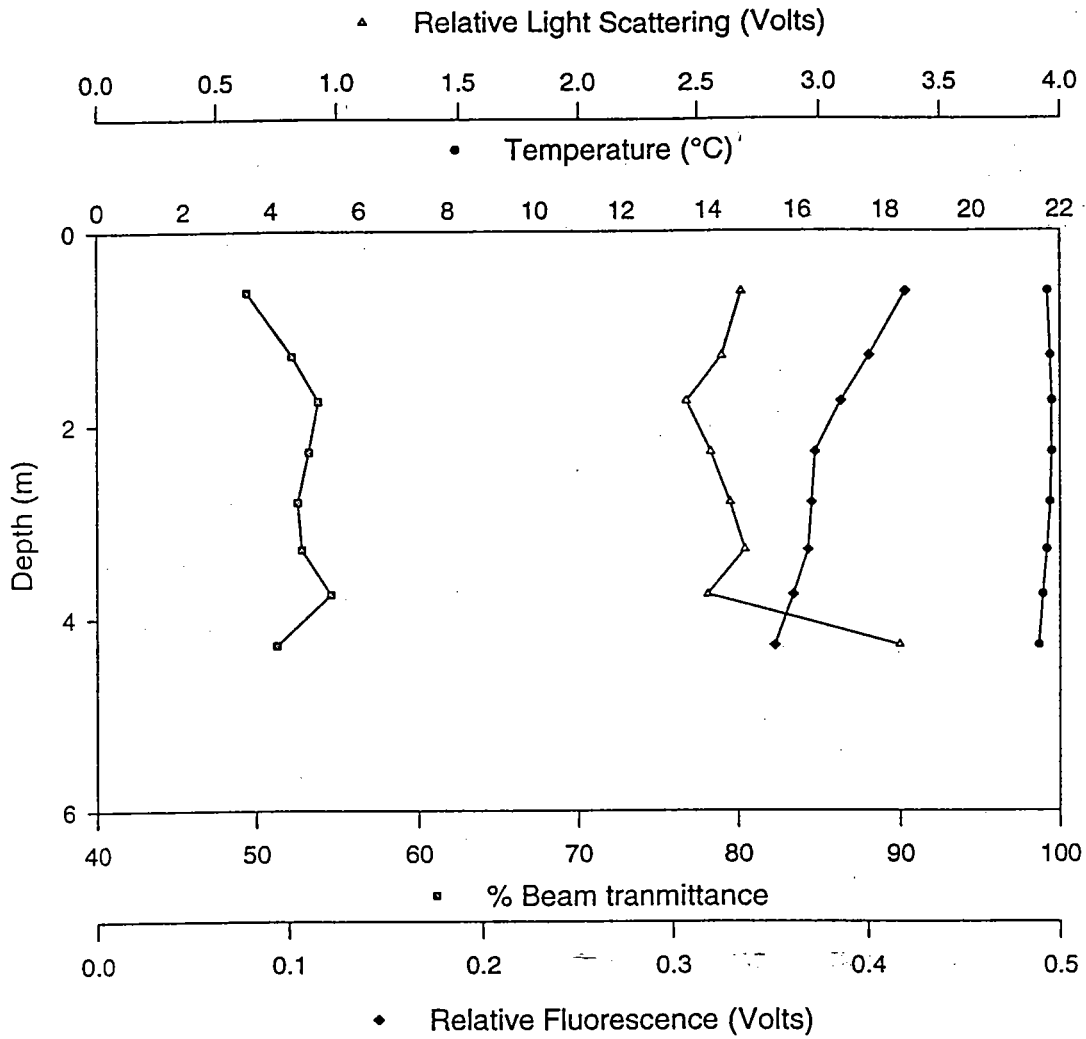

Figure A.7b - Station 2.1 Downcast



Diffuse Attenuation Coefficient ($k\lambda$)

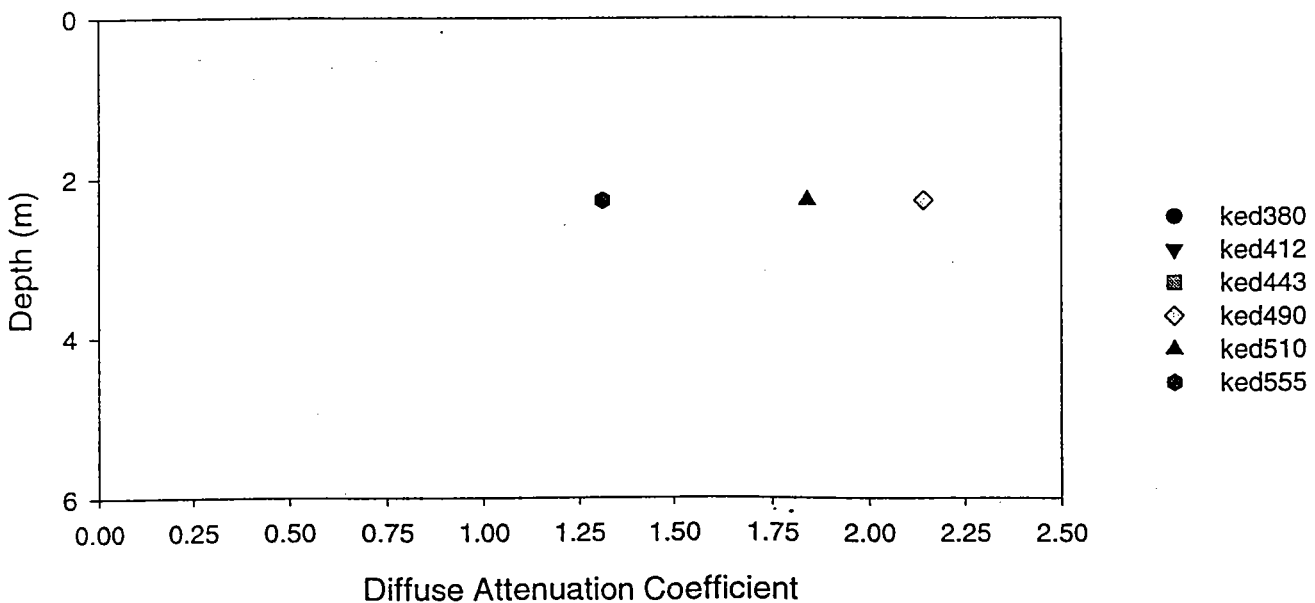

Figure A.8a - Station 2.1 Upcast

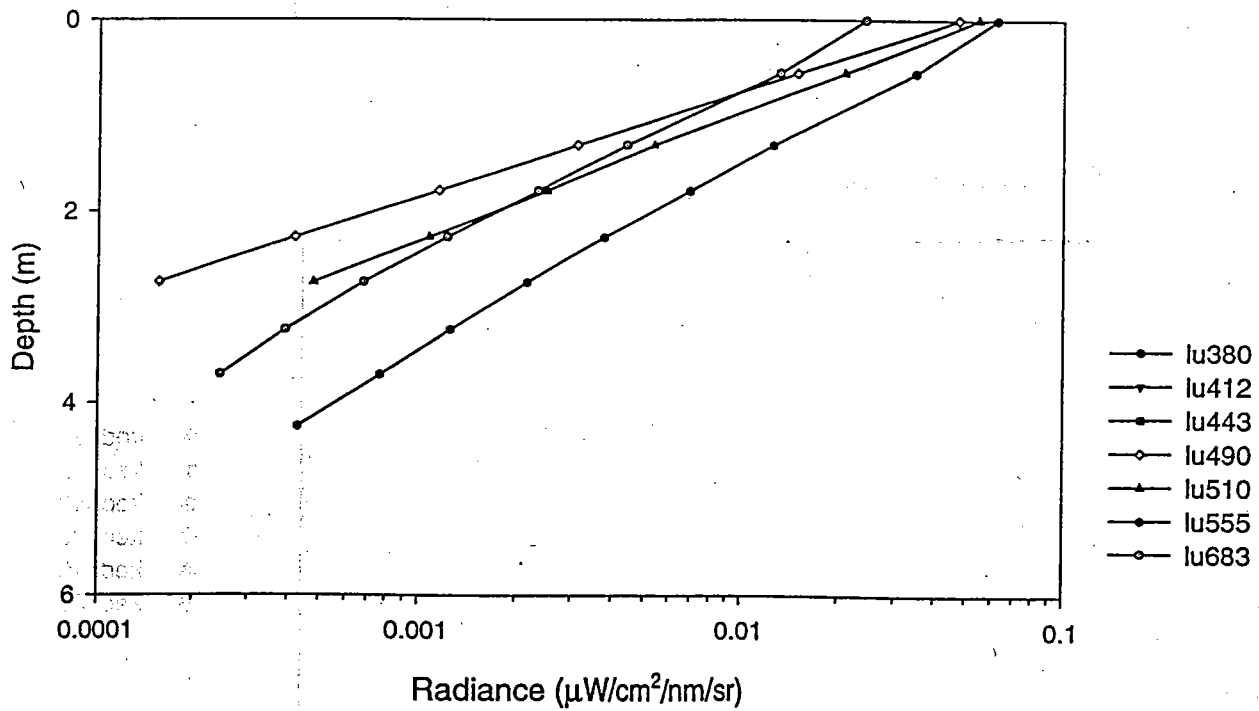
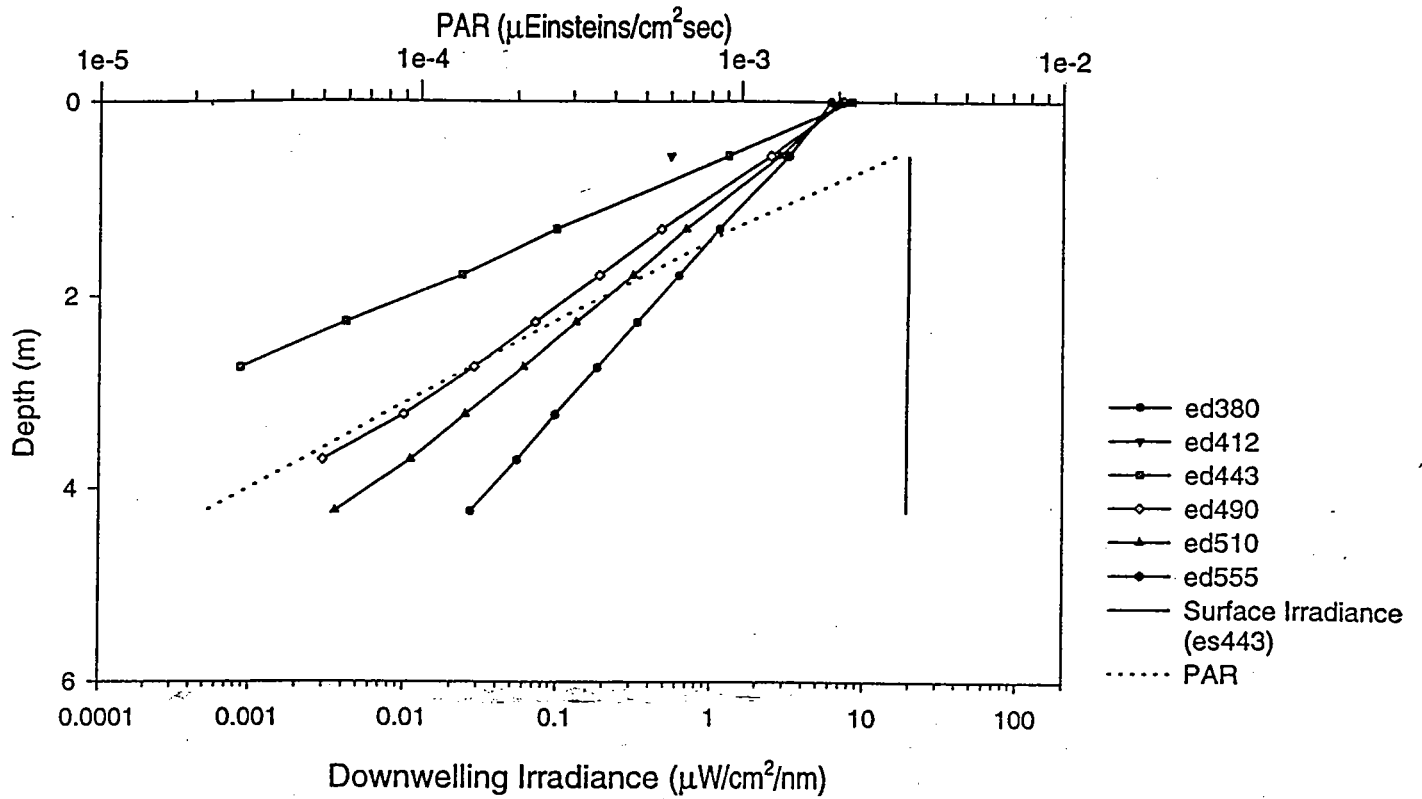
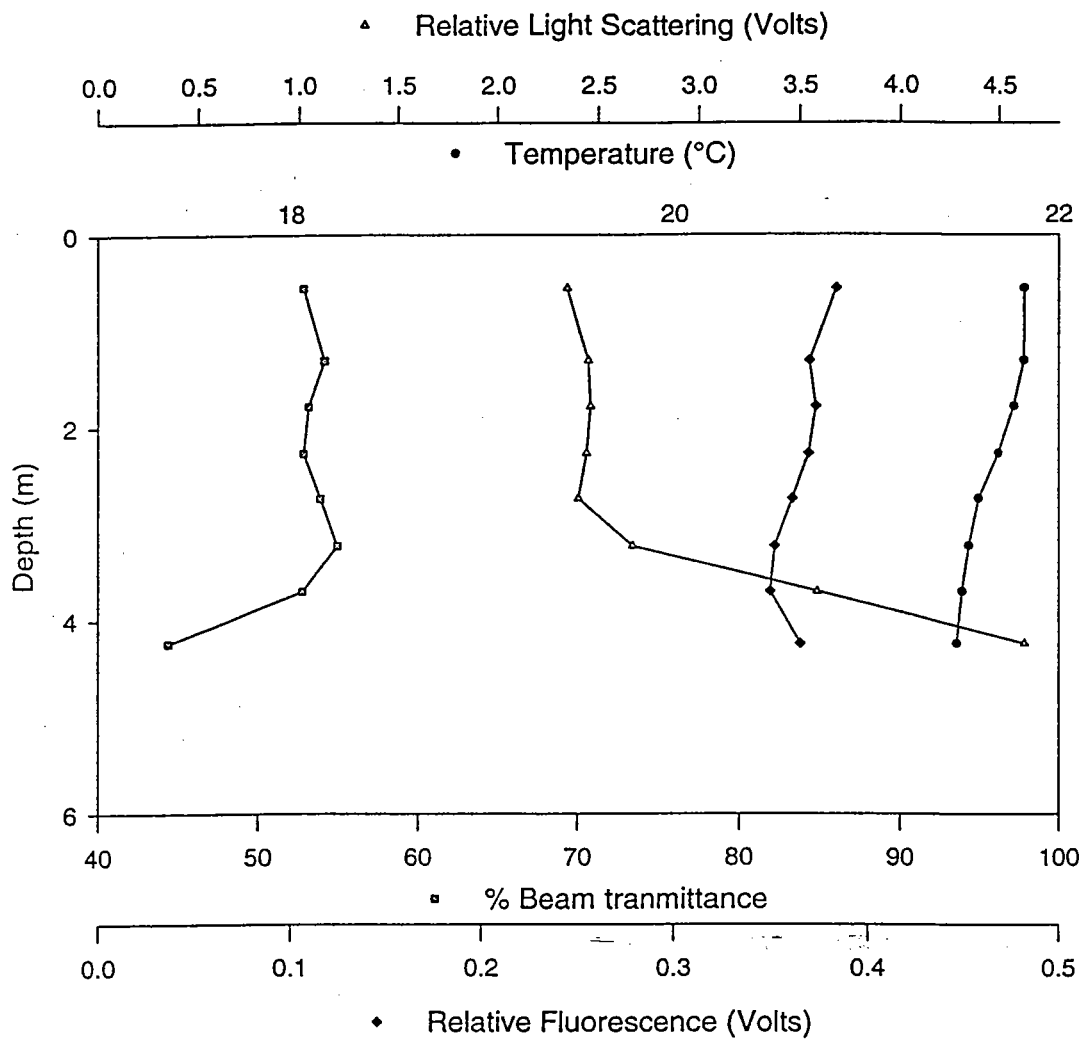

Figure A. 8b - Station 2.1 Upcast



Diffuse Attenuation Coefficient ($k\lambda$)

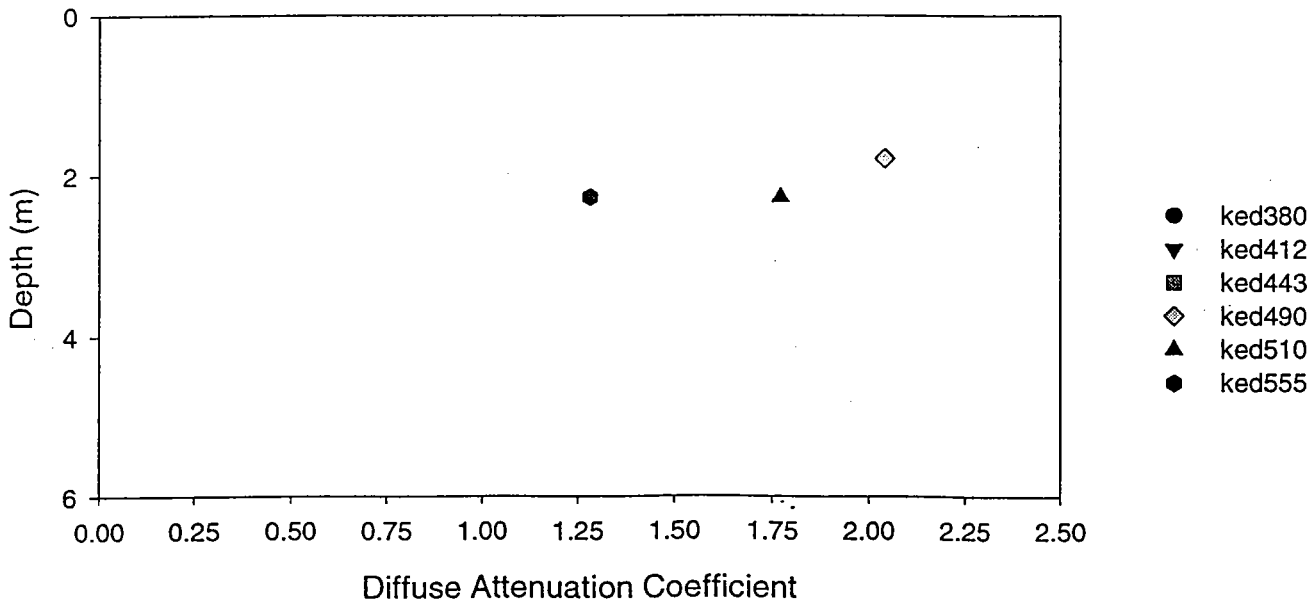

Figure A.9a - Station 2.2 Downcast

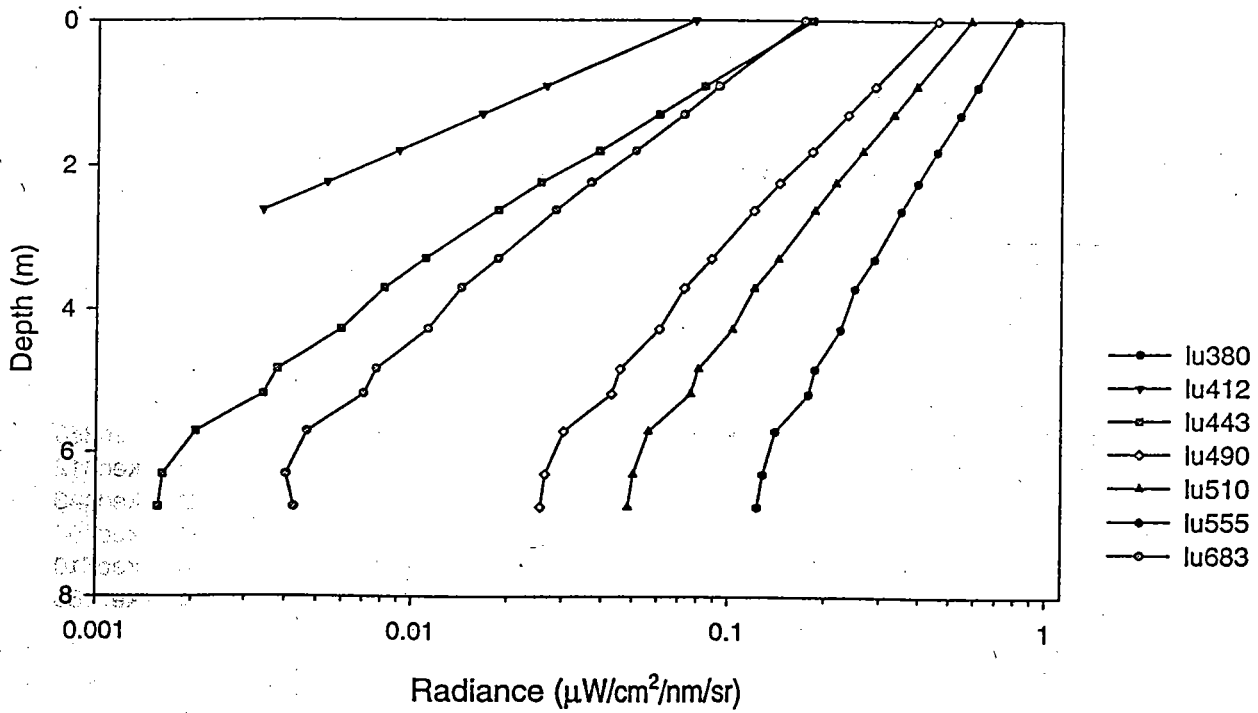
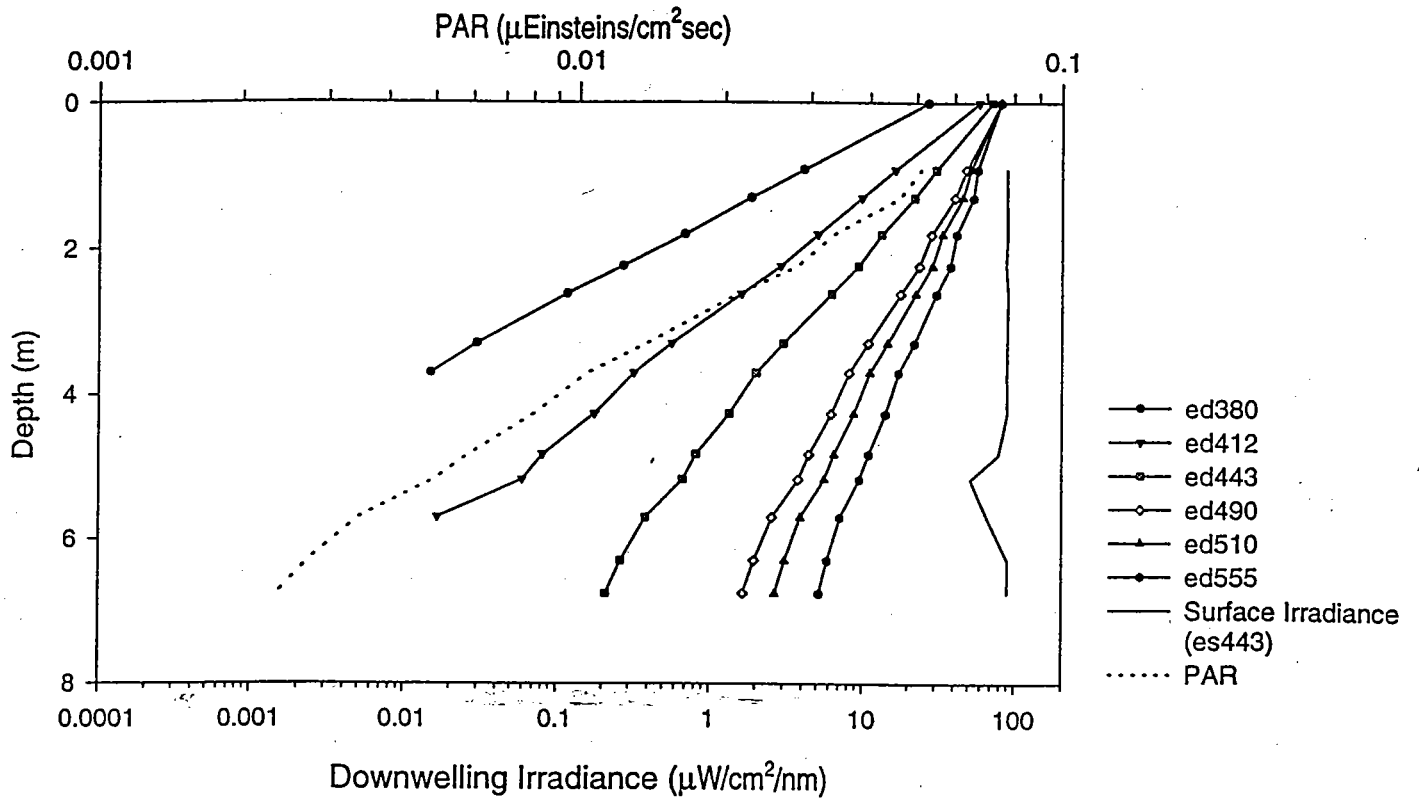
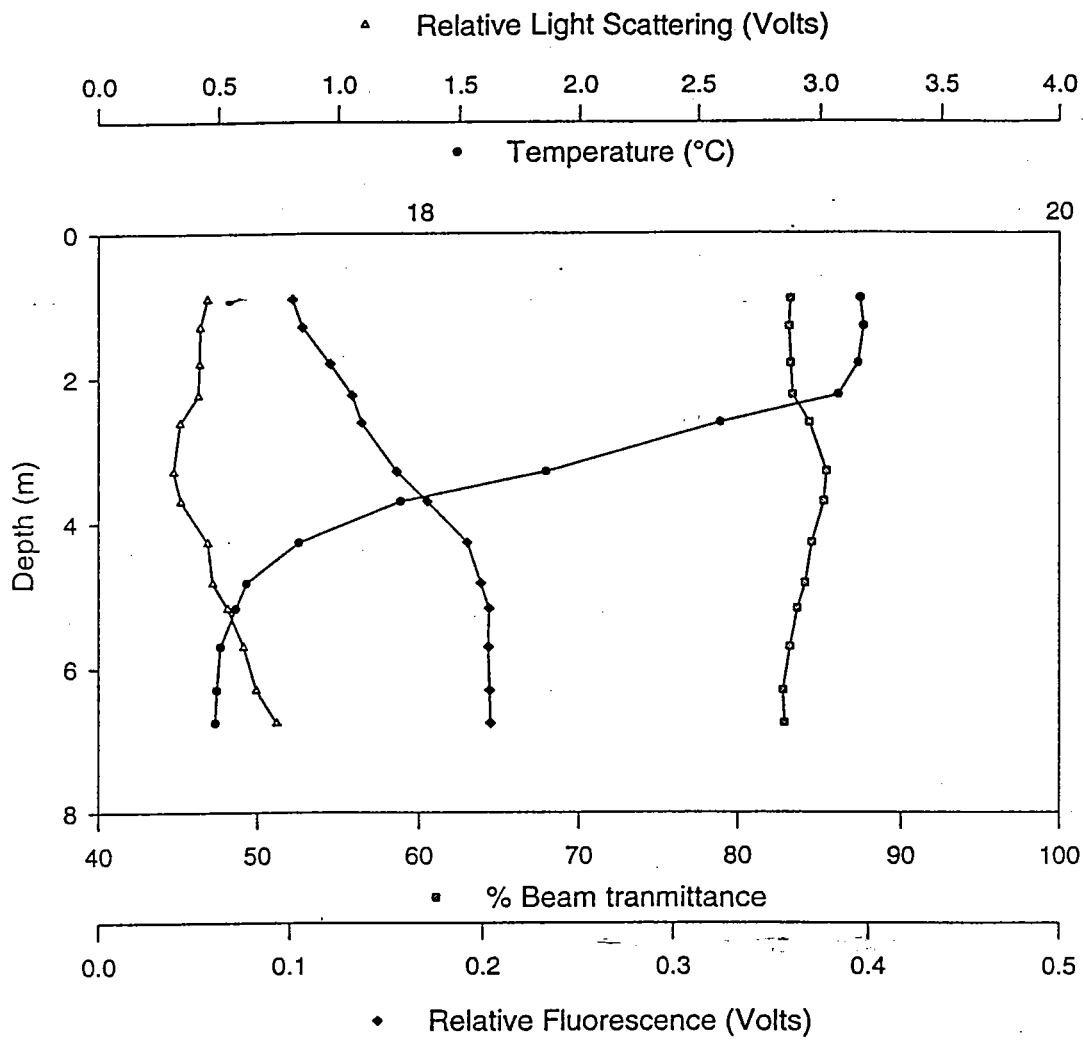

Figure A. 9b - Station 2.2 Downcast



Diffuse Attenuation Coefficient (k_{λ})

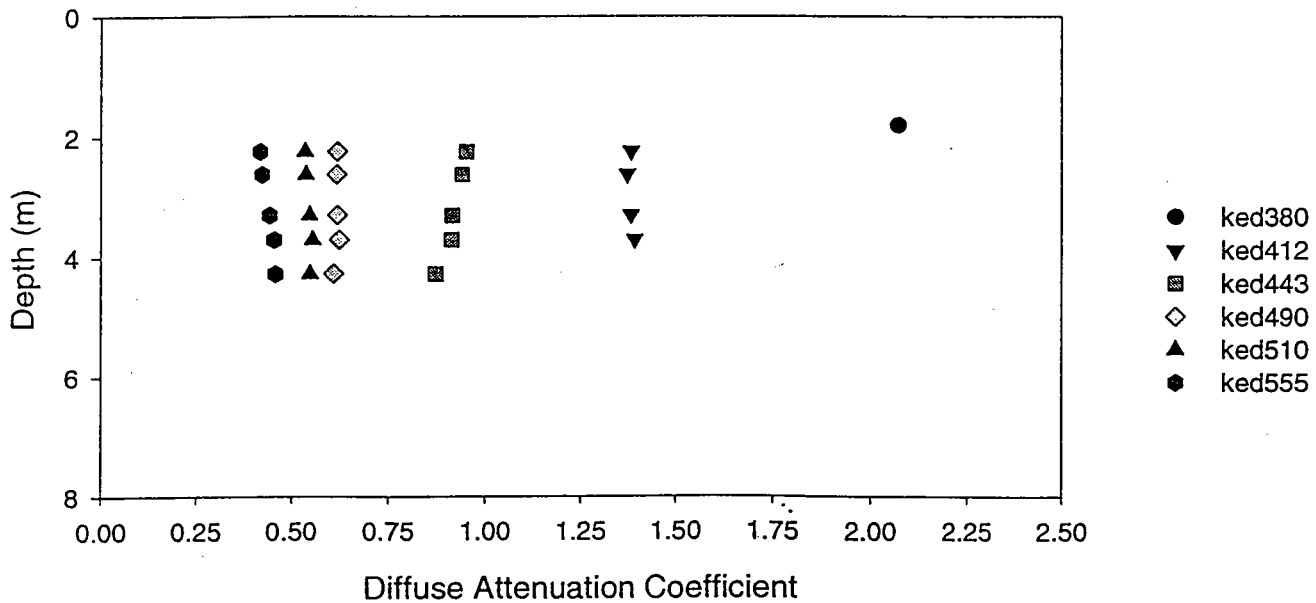

Figure A.10a - Station 2.2 Upcast

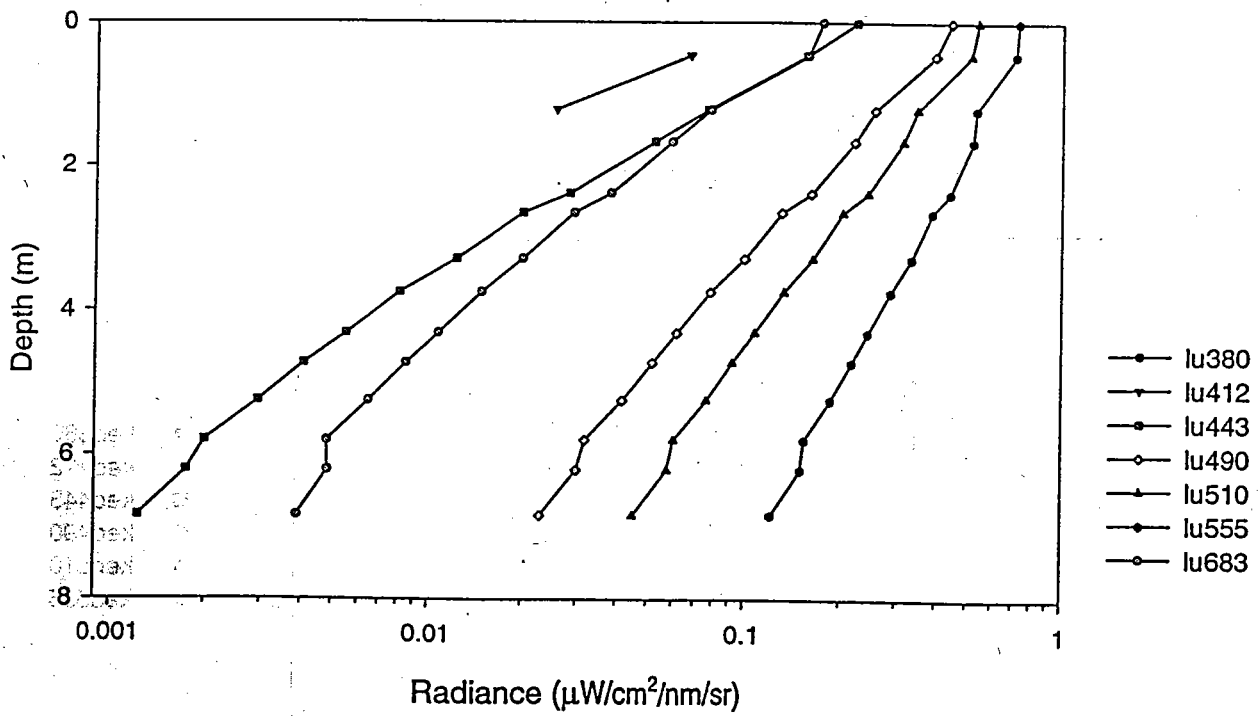
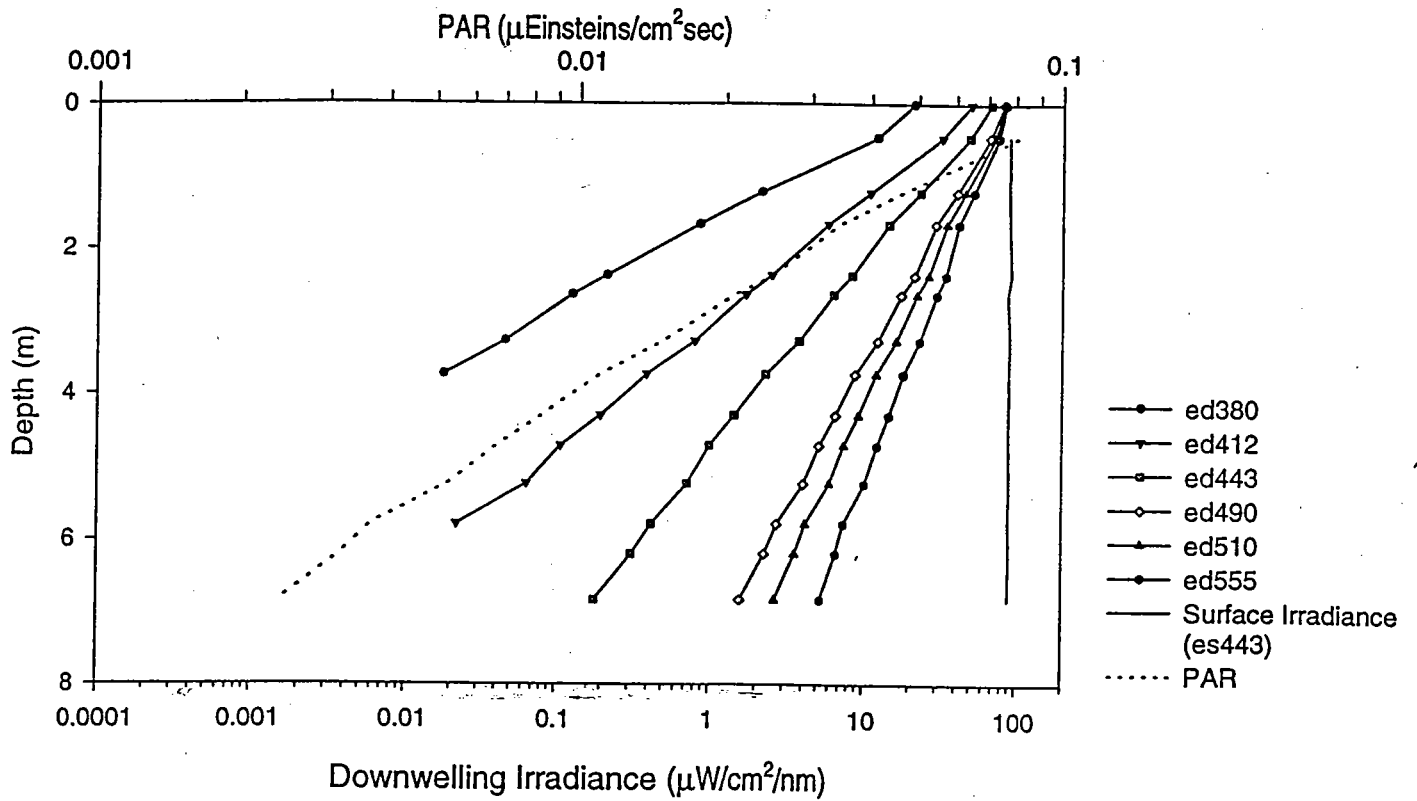
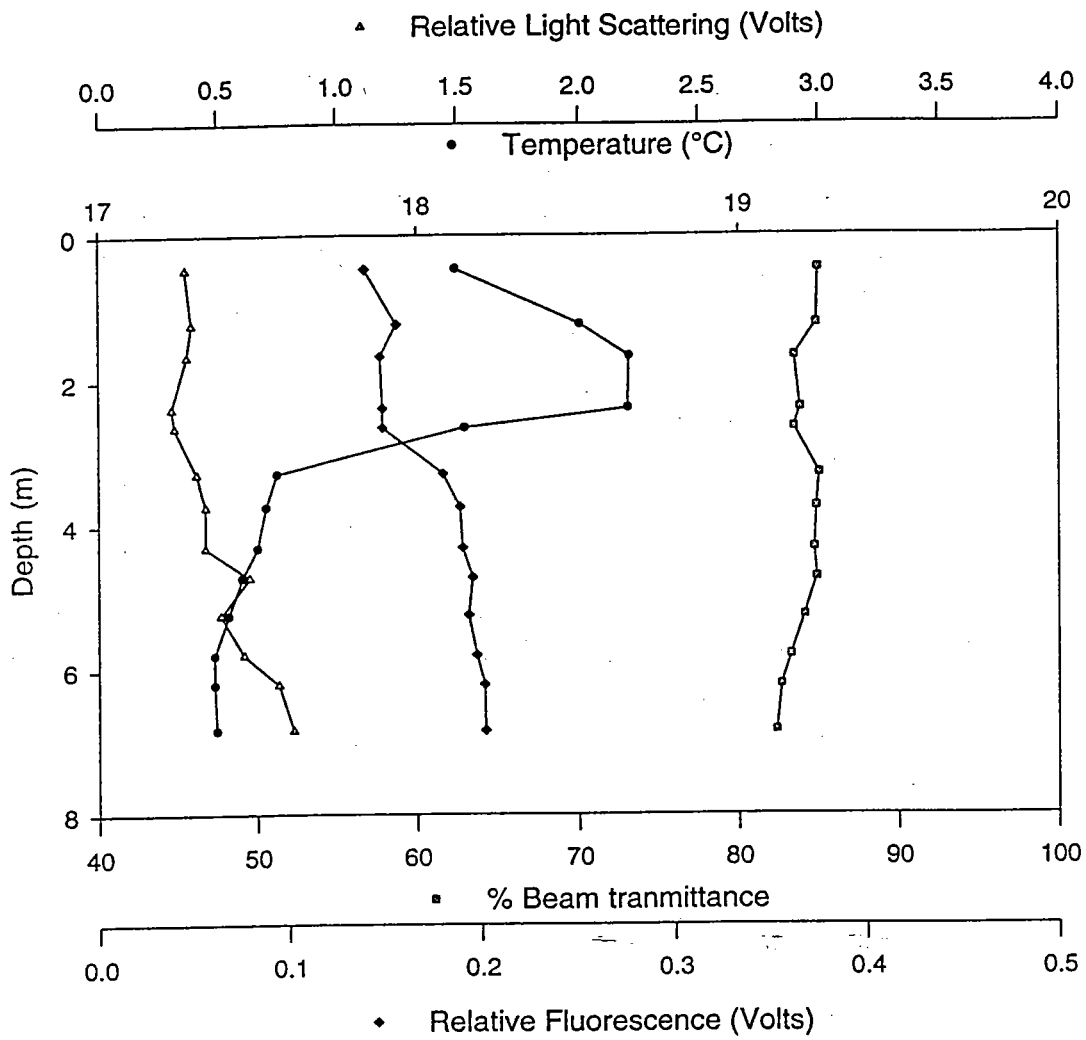

Figure A.10b - Station 2.2 Upcast



Diffuse Attenuation Coefficient ($k\lambda$)

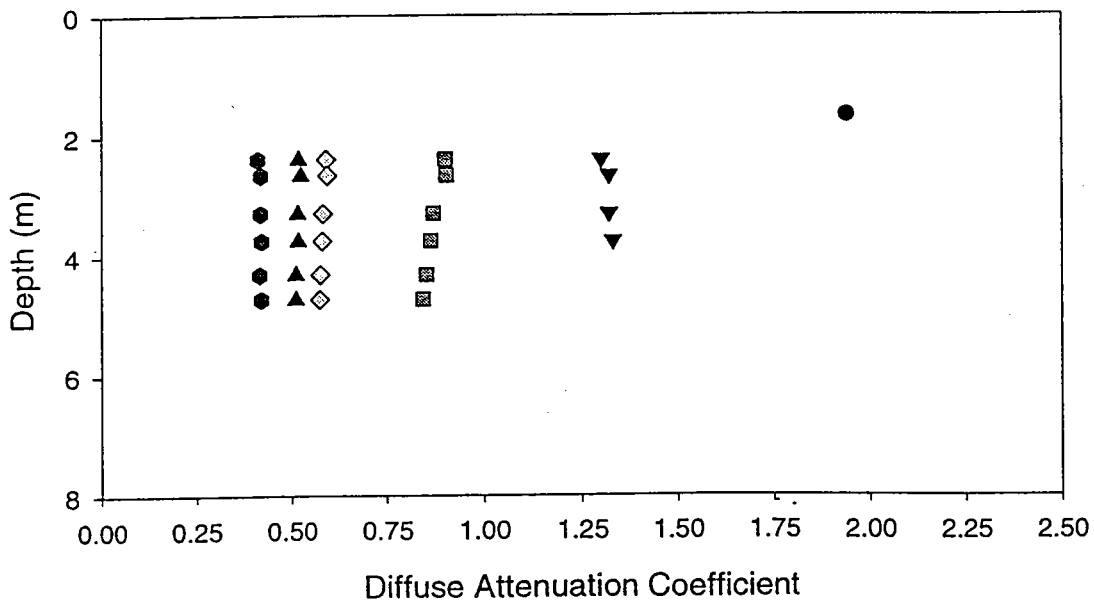

Figure A.11a - Station 2.3 Downcast

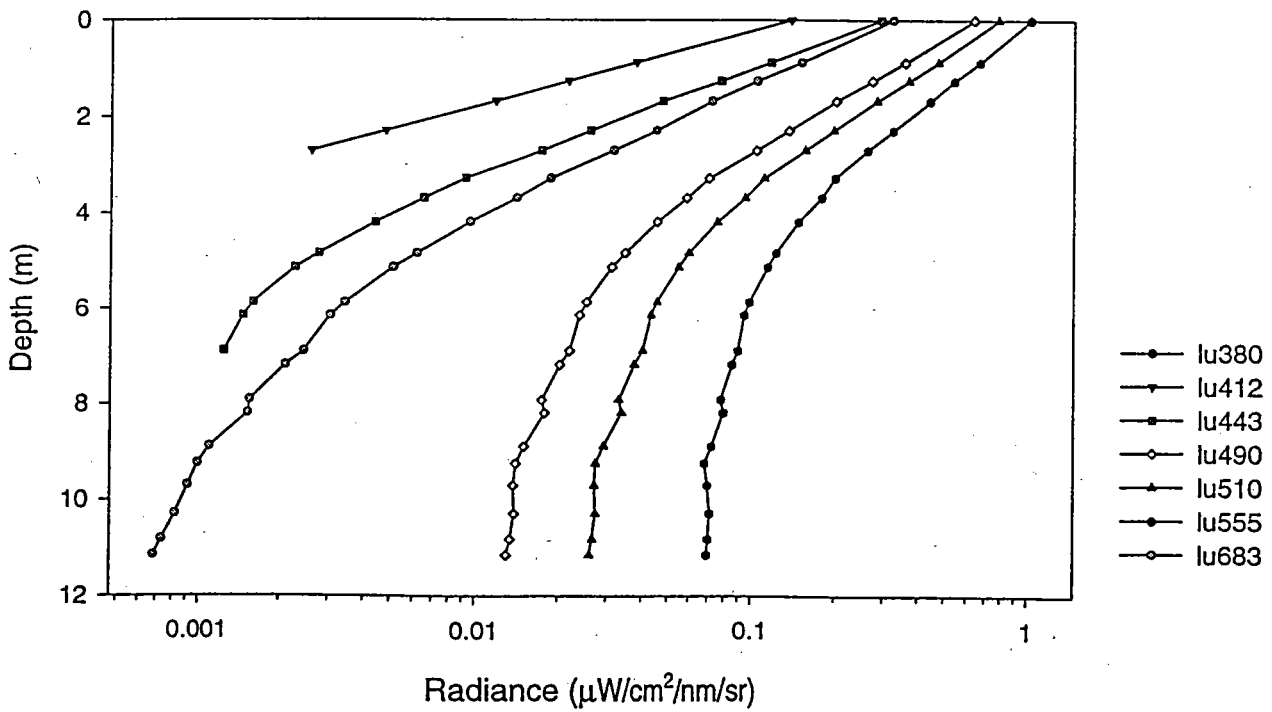
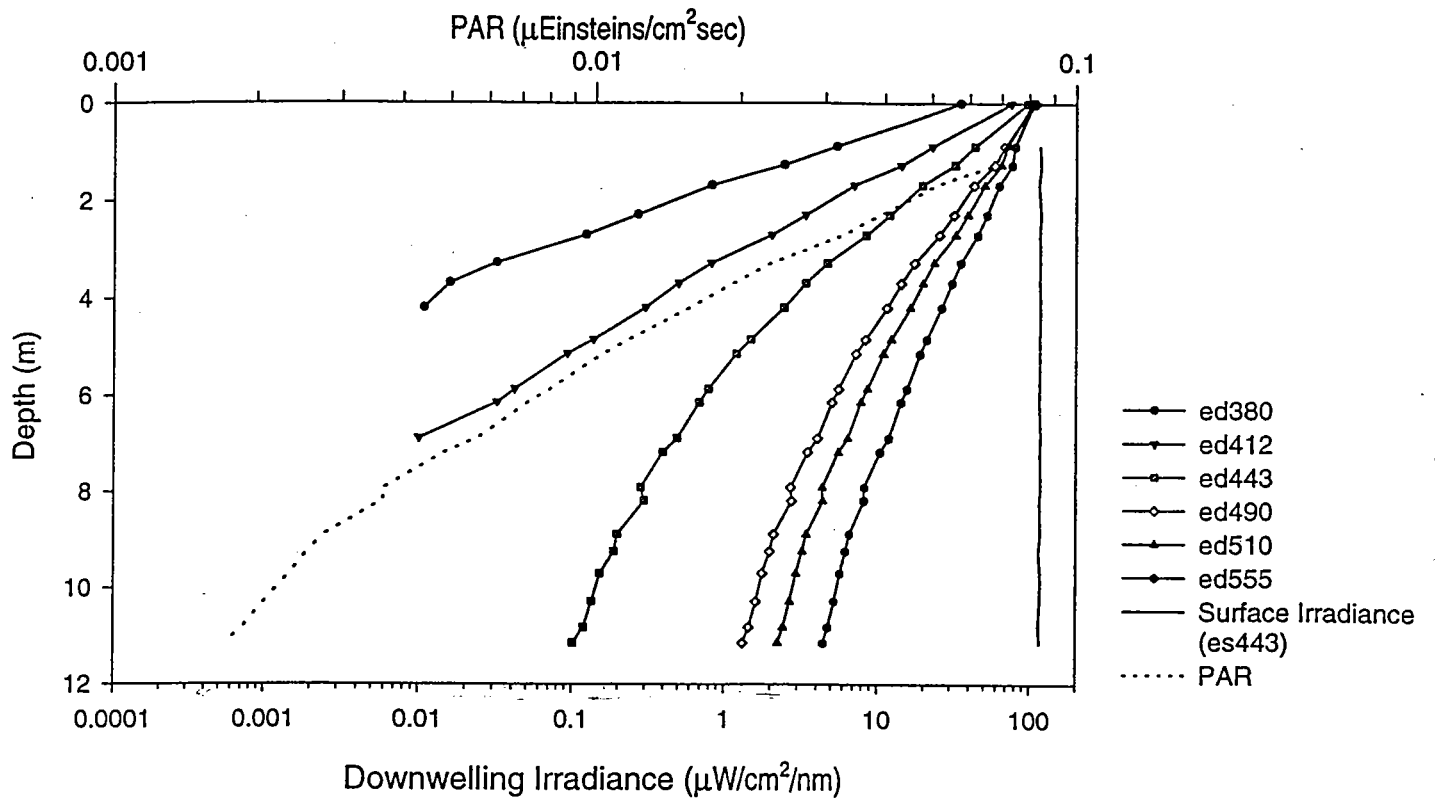
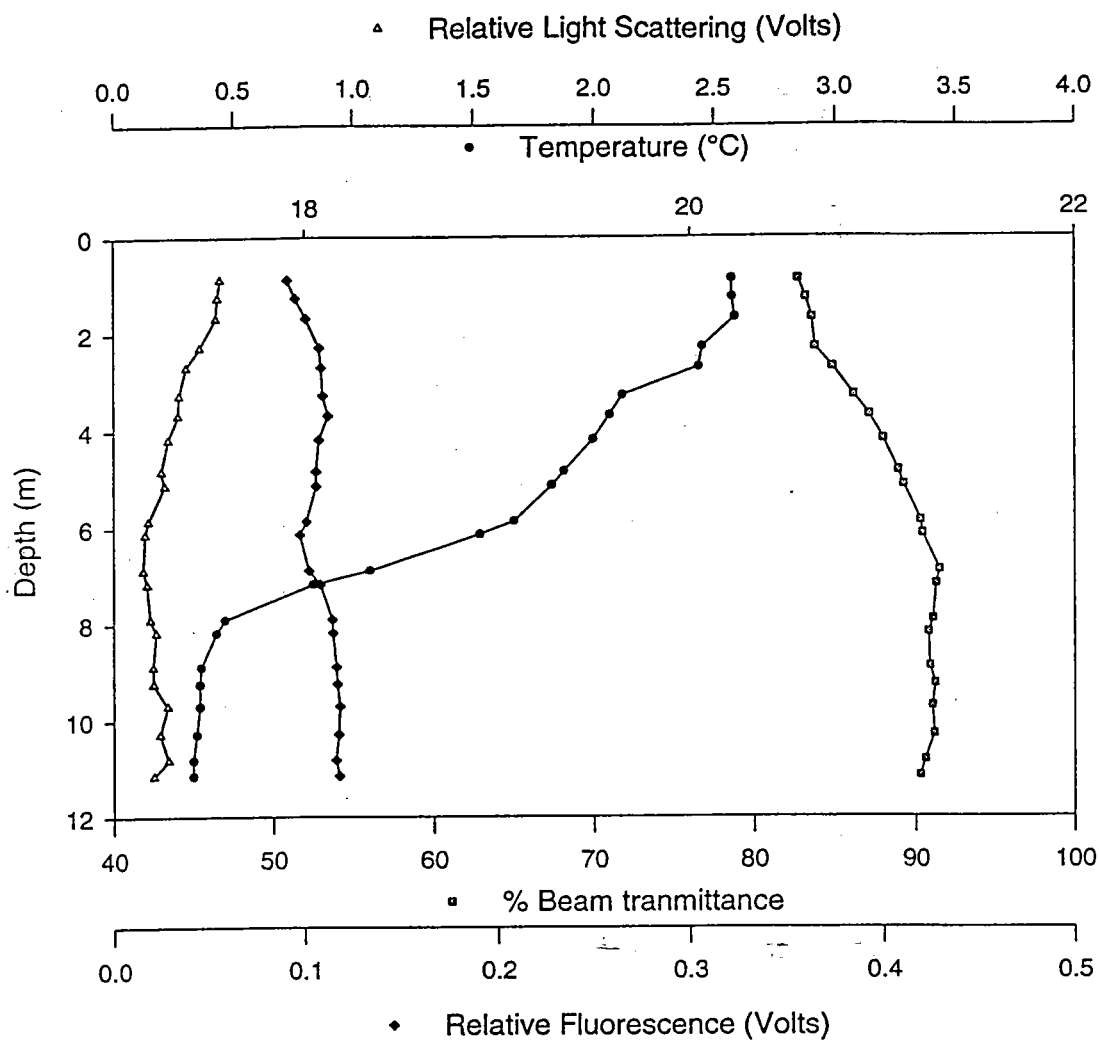

Figure A.11b - Station 2.3 Downcast



Diffuse Attenuation Coefficient ($k\lambda$)

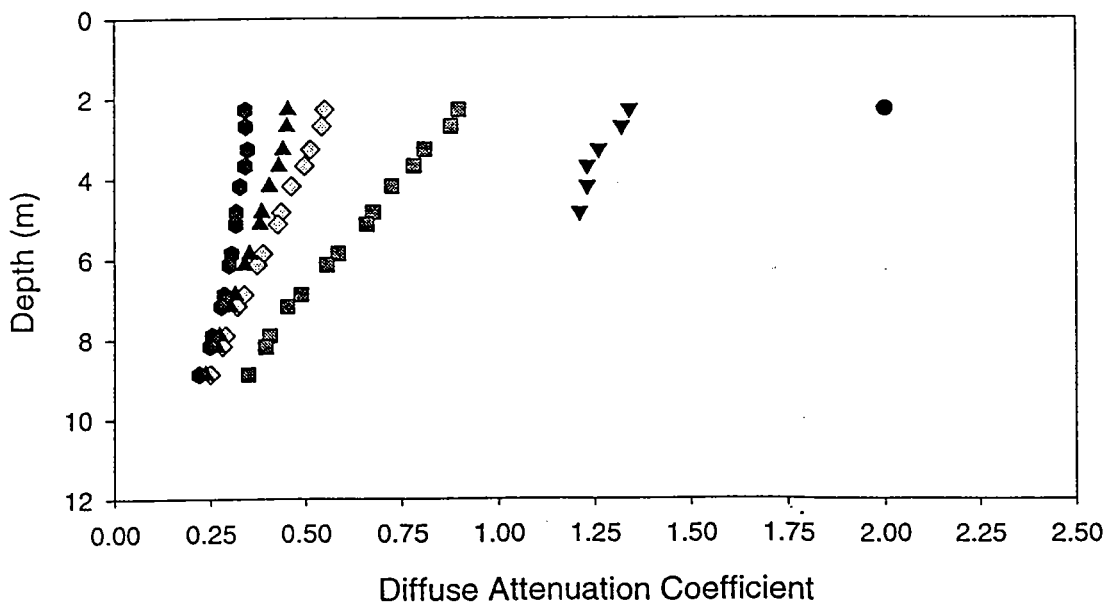

Figure A.12a - Station 2.3 Upcast

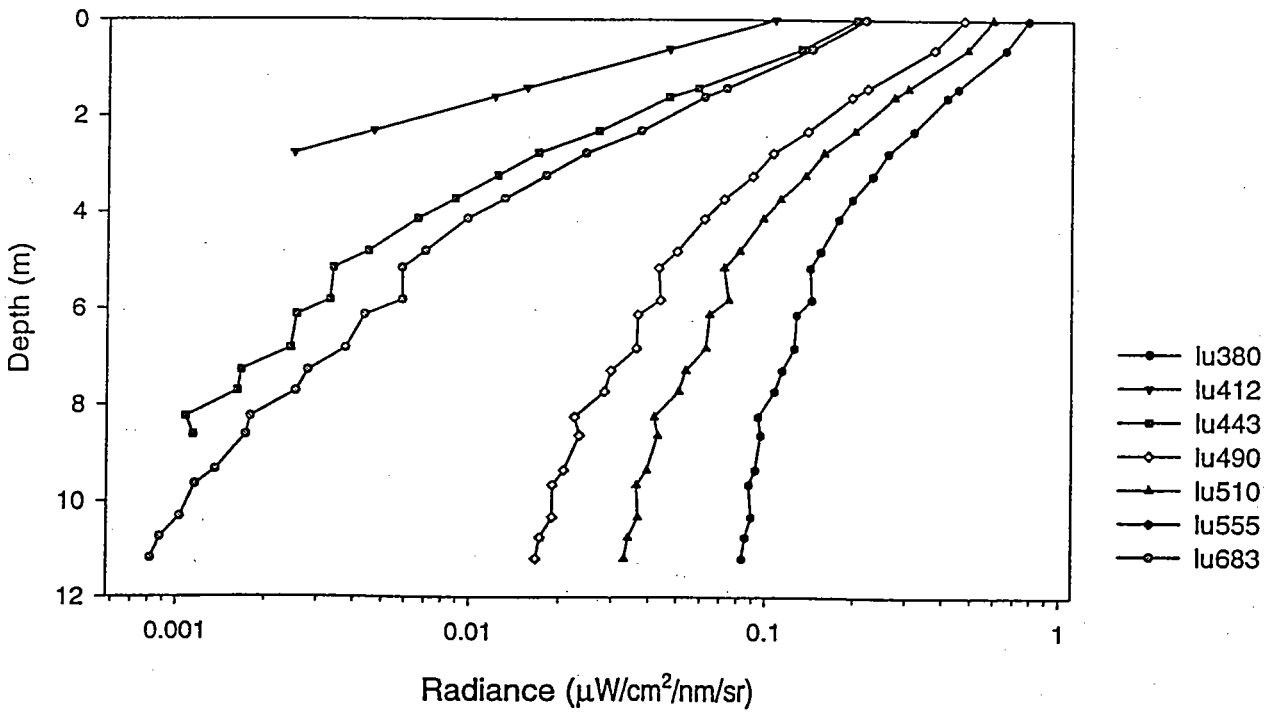
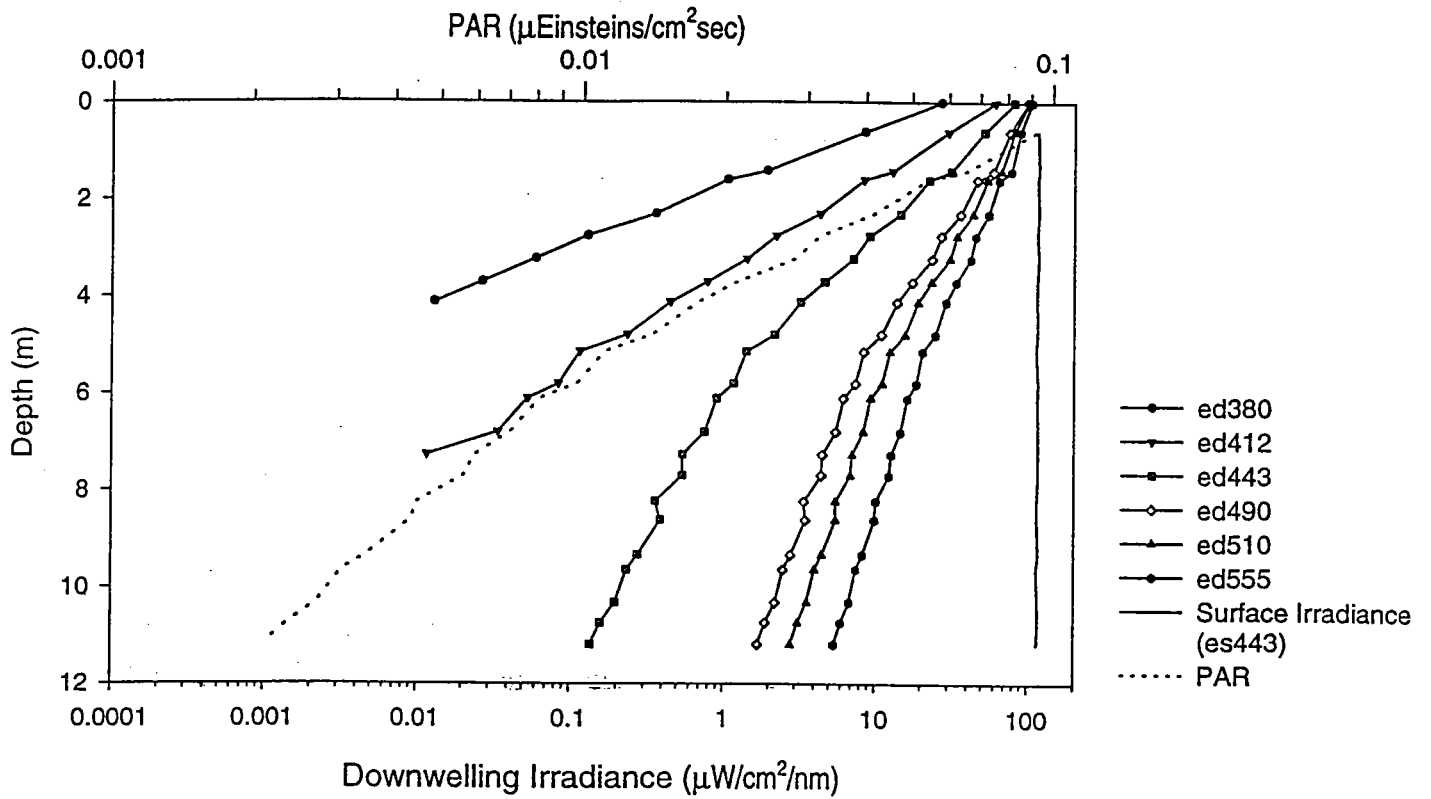
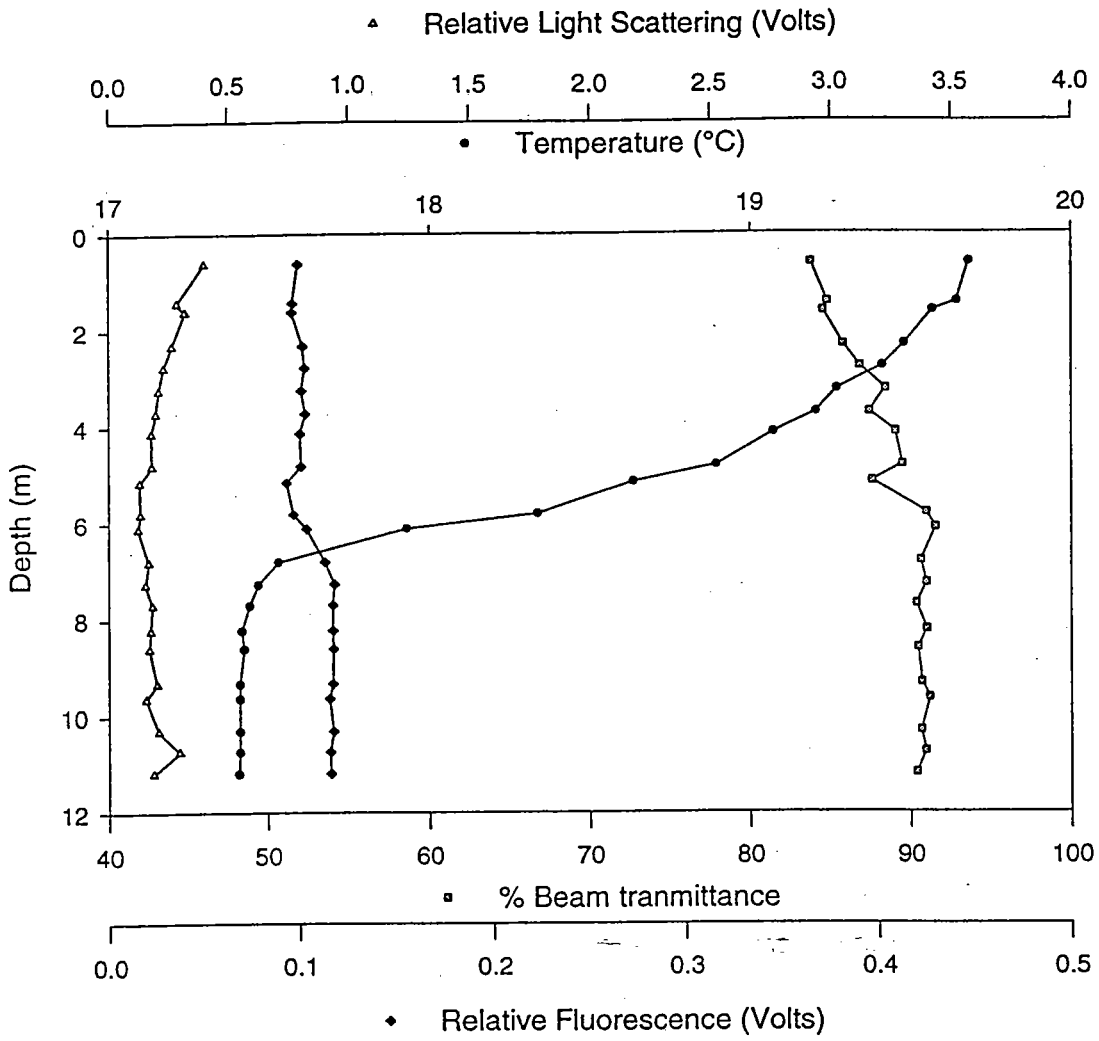

Figure A.12b - Station 2.3 Upcast



Diffuse Attenuation Coefficient ($k\lambda$)

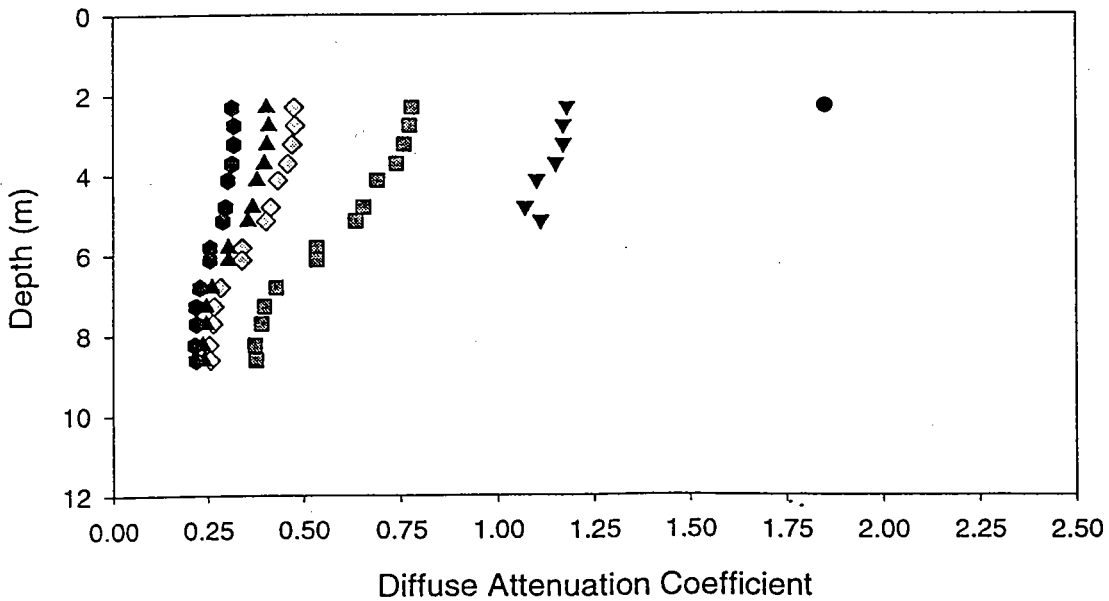

Figure A.13a - Station 2.4 Downcast

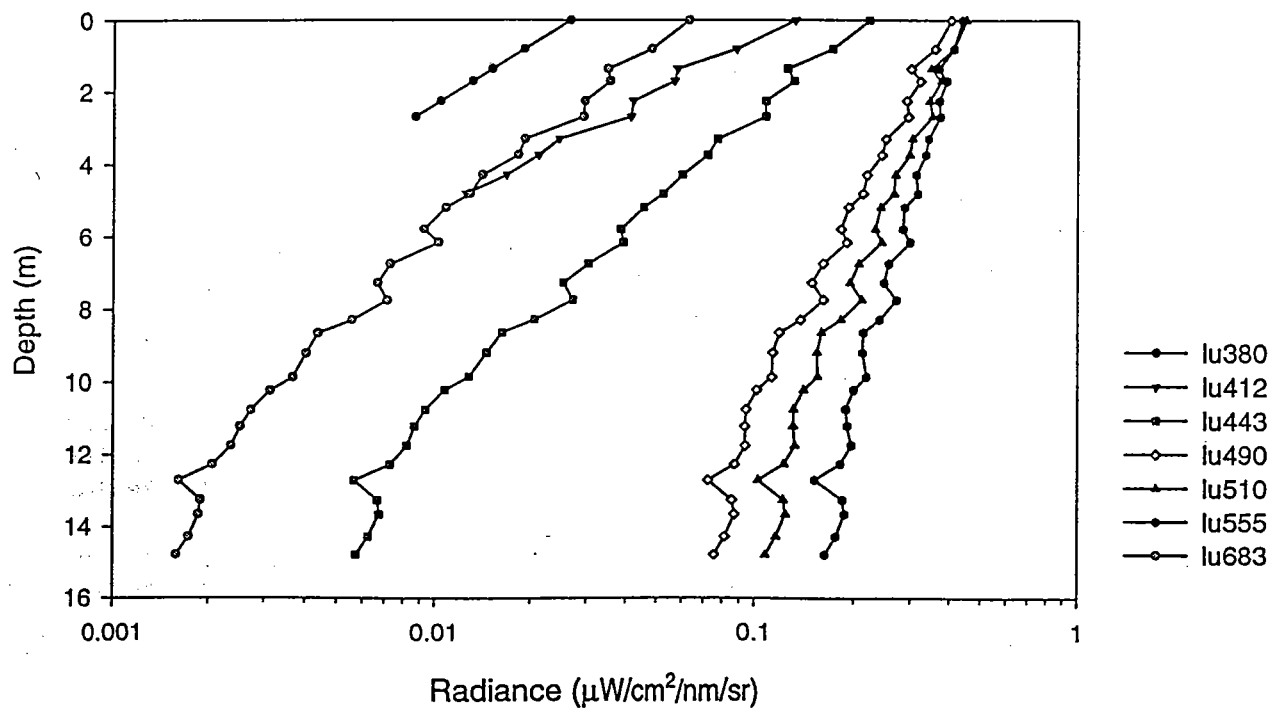
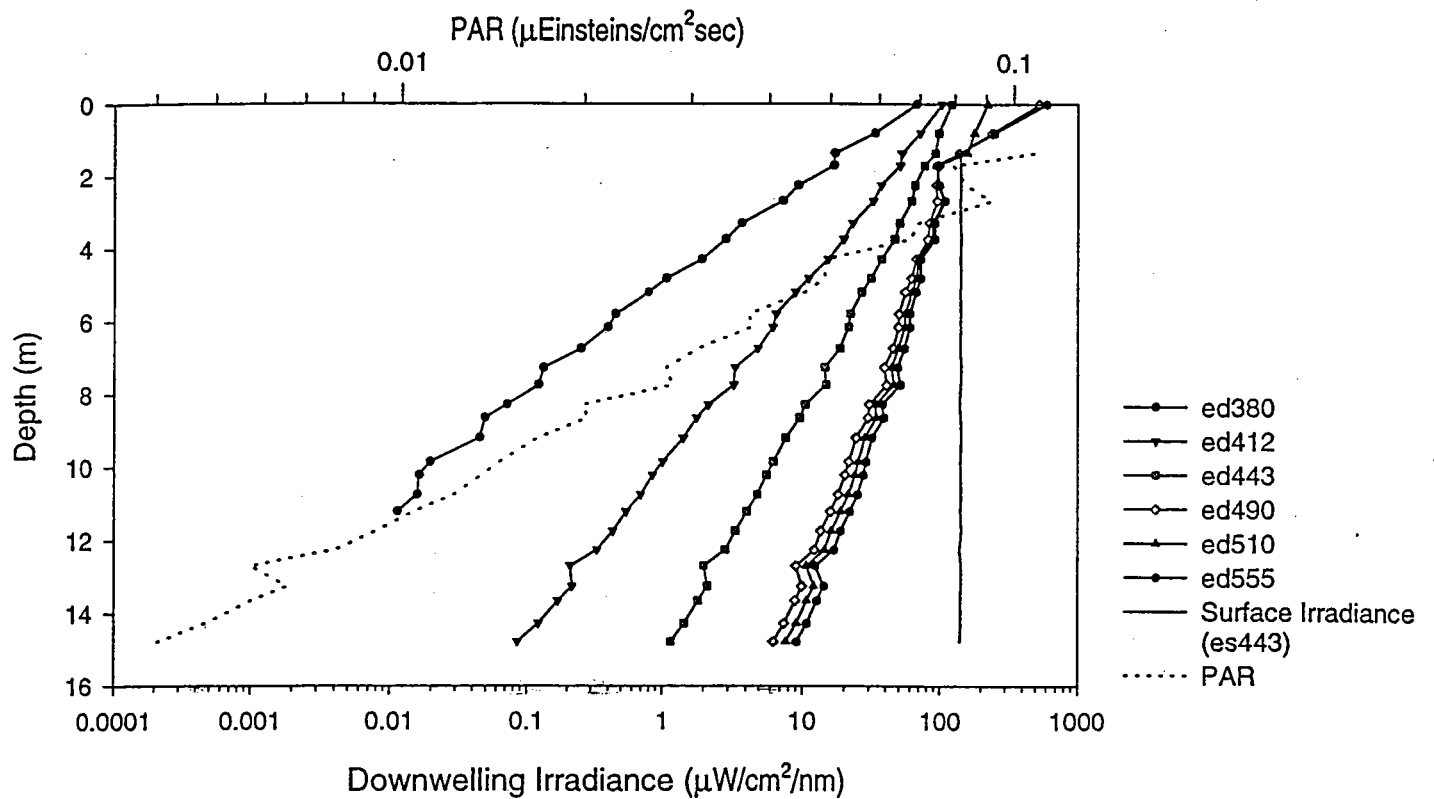
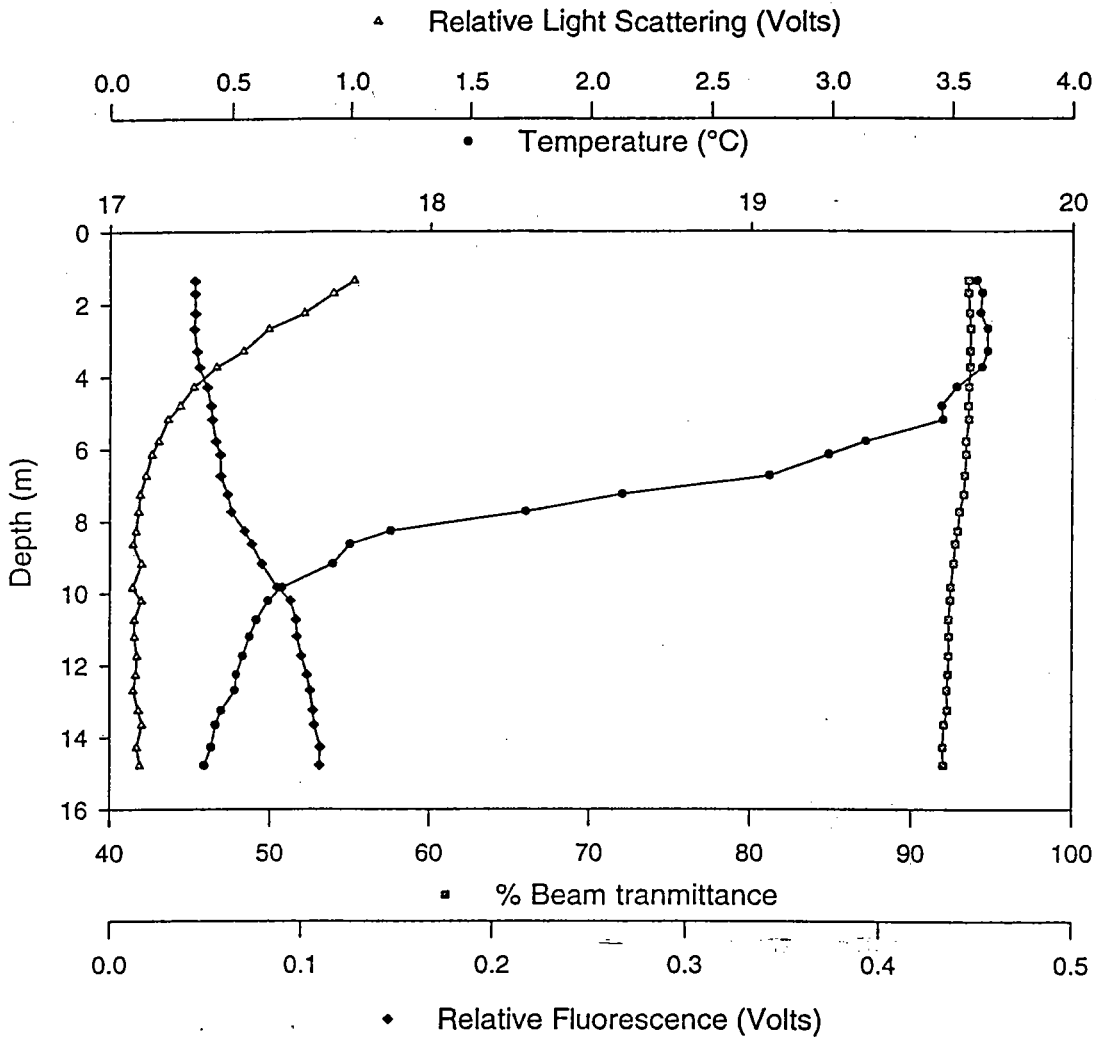

Figure A.13b - Station 2.4 Downcast



Diffuse Attenuation Coefficient ($k\lambda$)

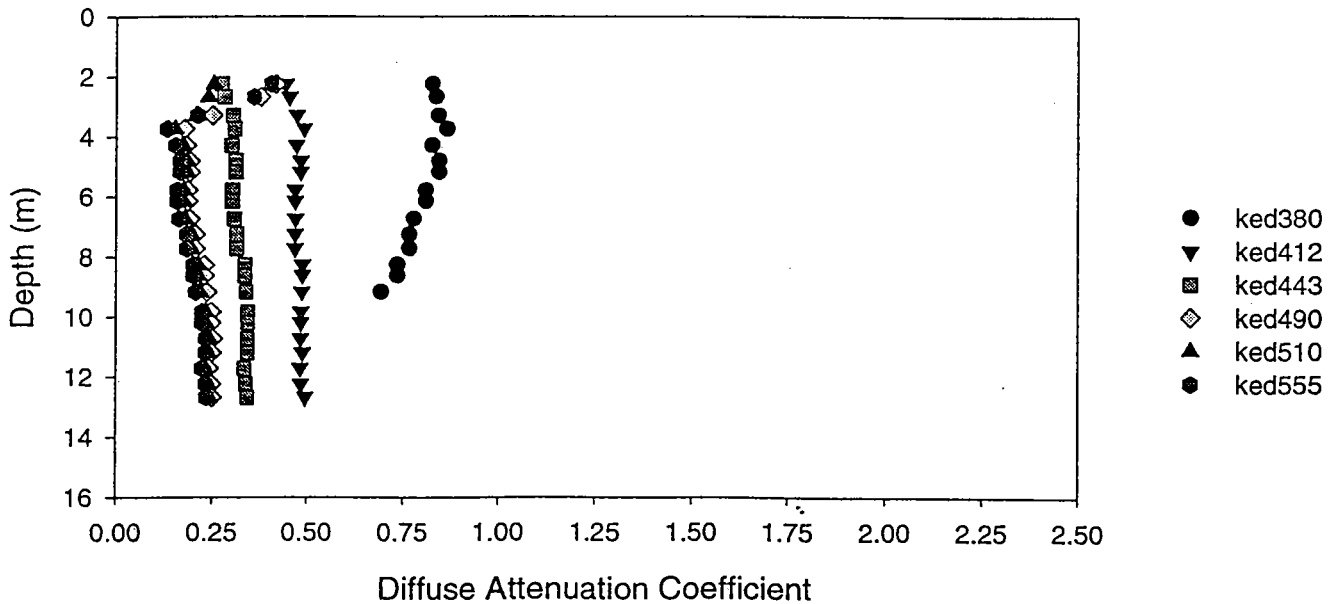

Figure A.14a - Station 2.4 Upcast

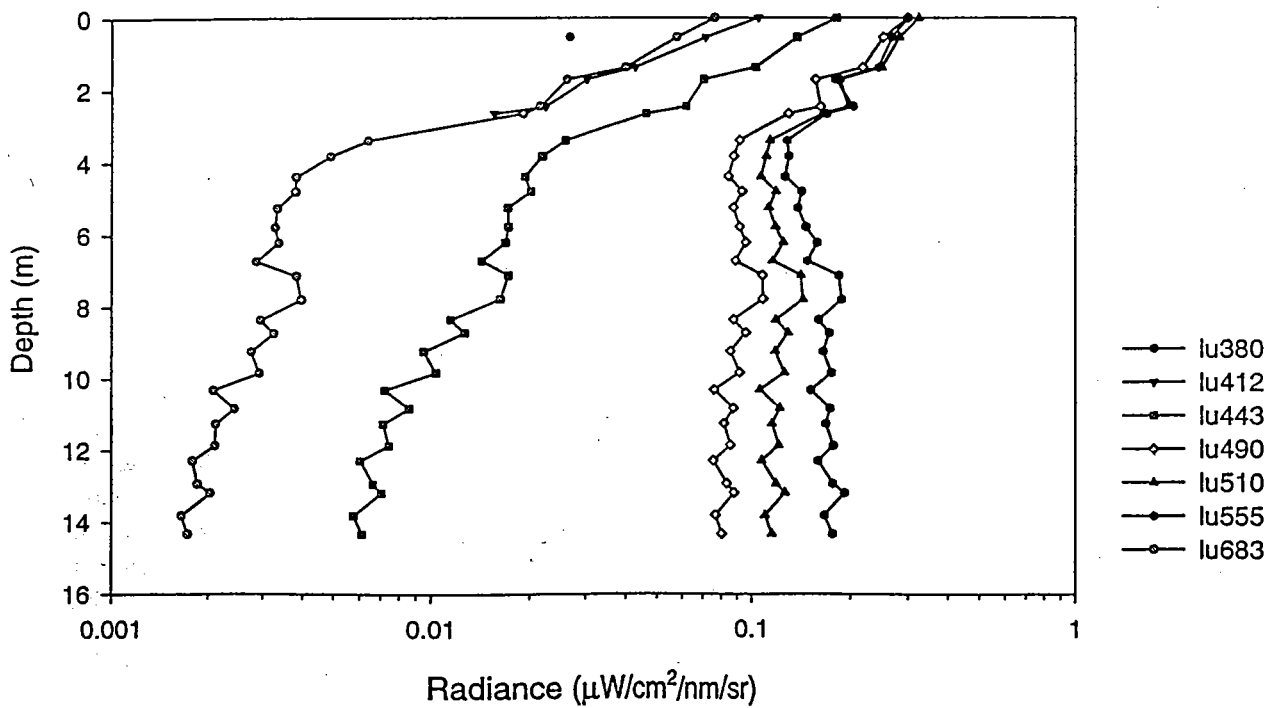
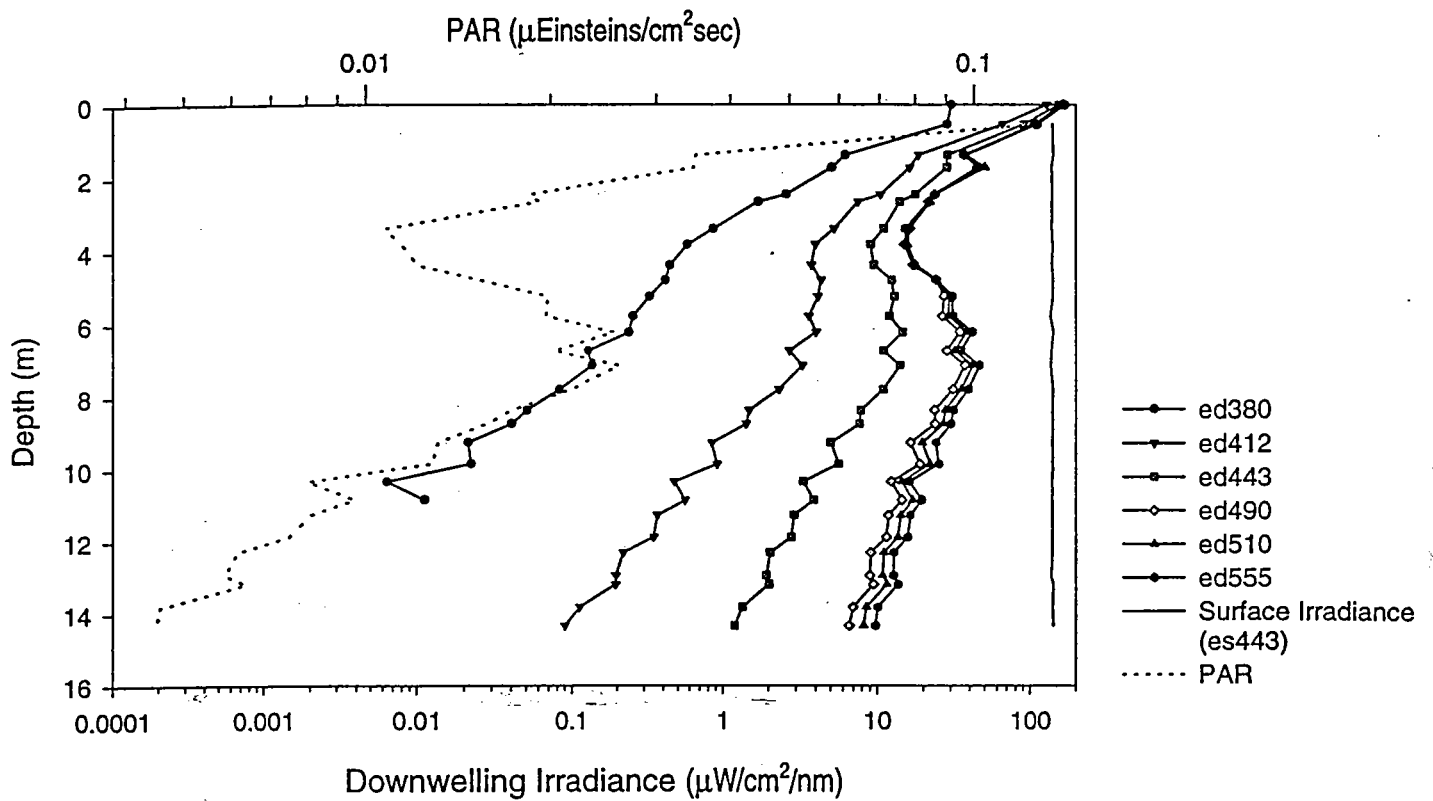
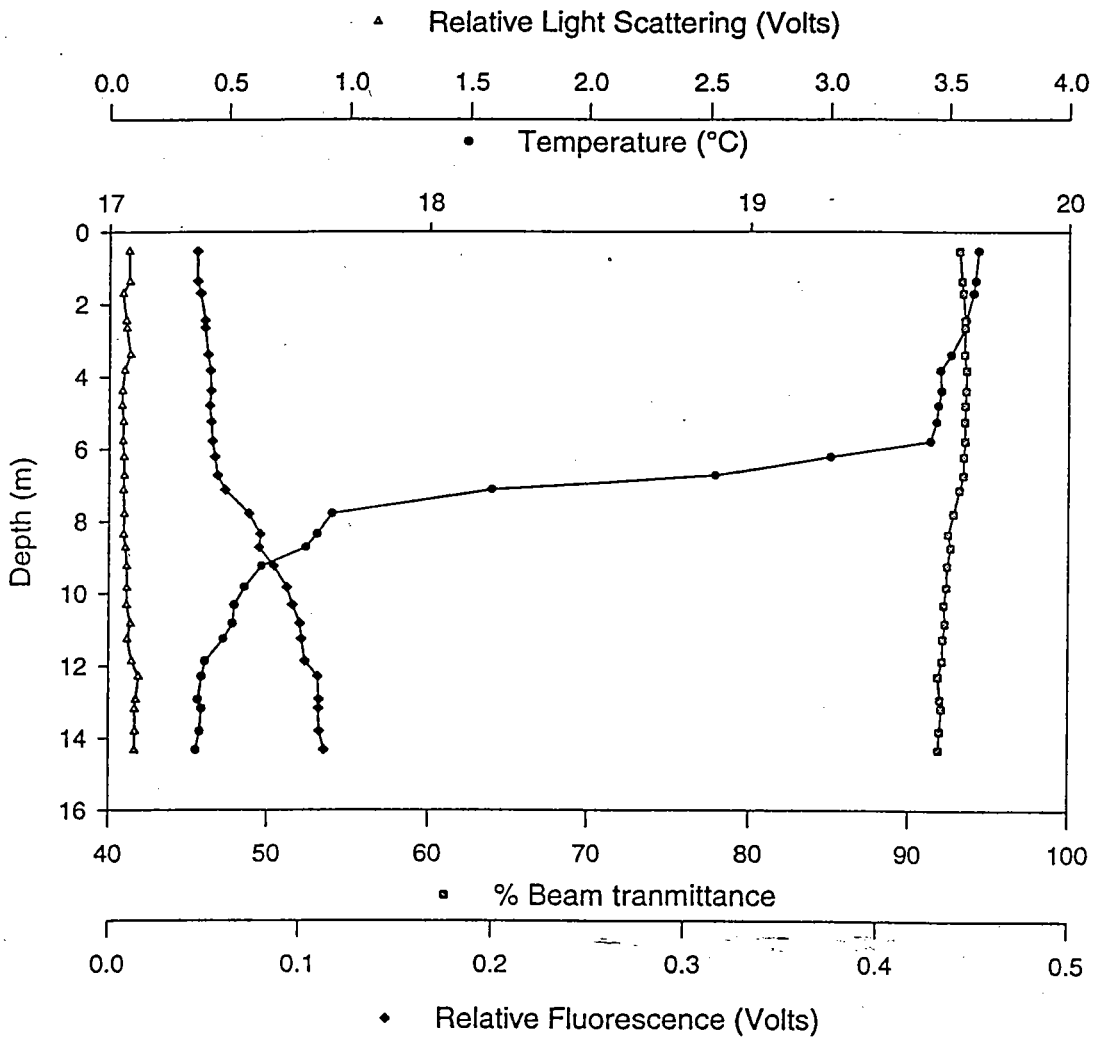

Figure A.14b - Station 2.4 Upcast



Diffuse Attenuation Coefficient ($k\lambda$)

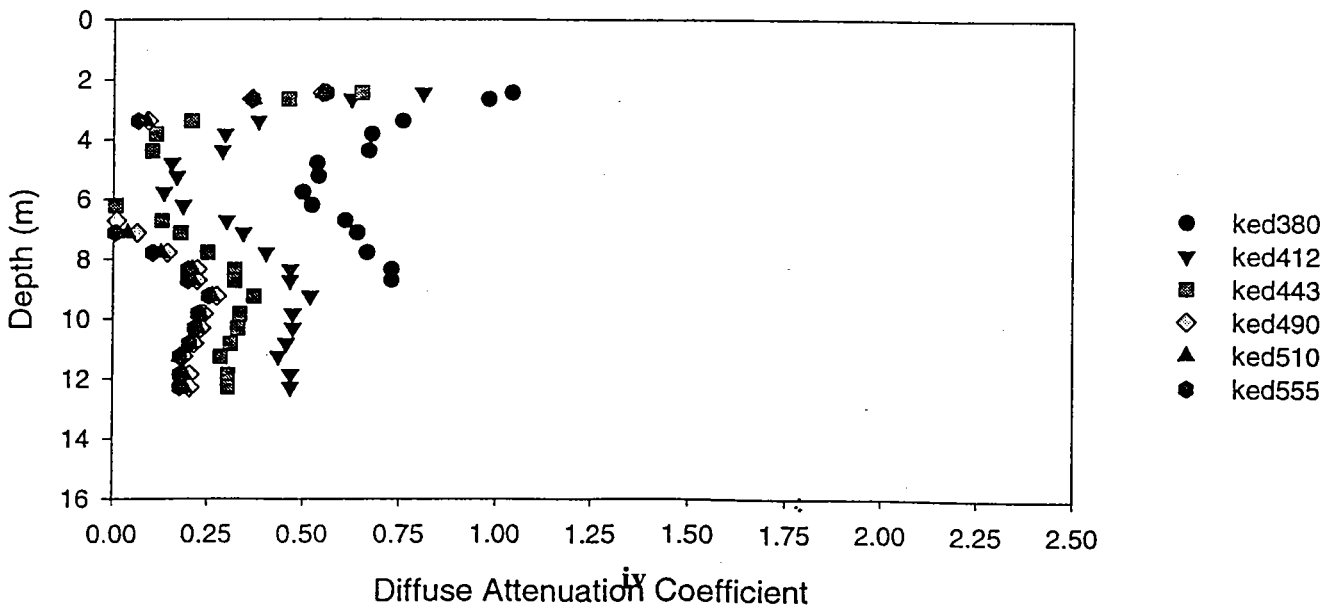

Figure A.15a - Station 2.5 Downcast

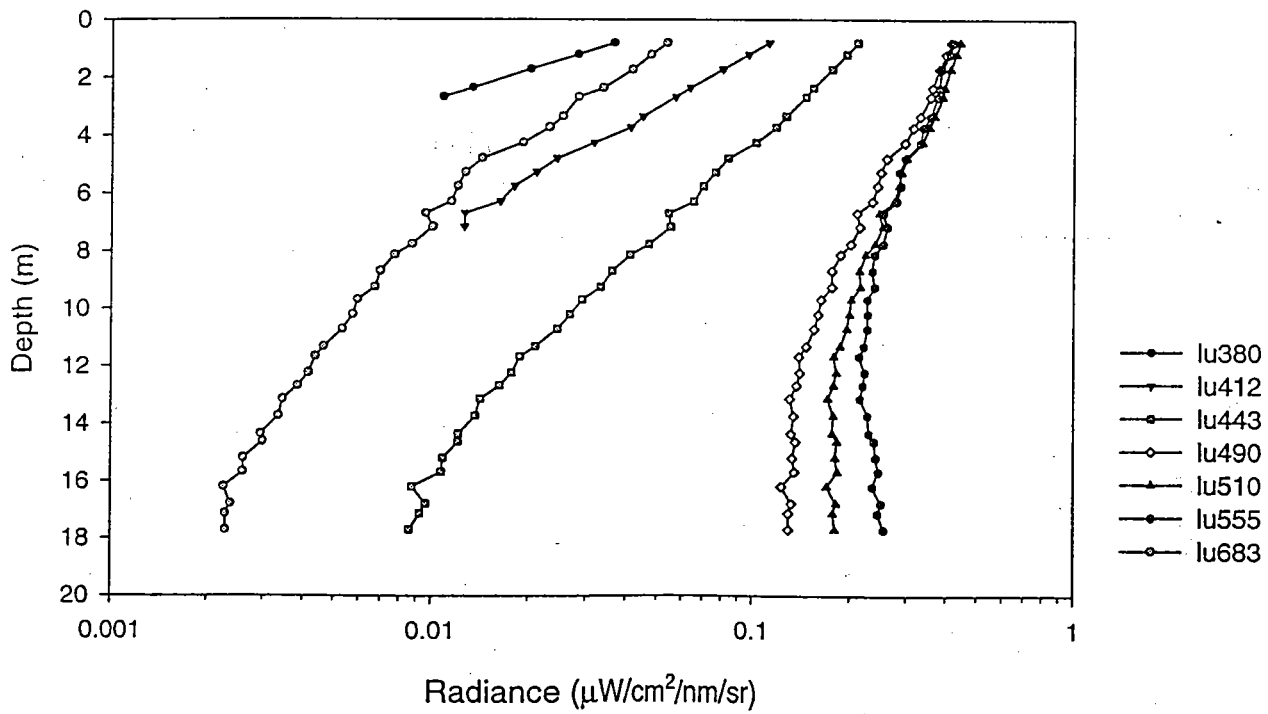
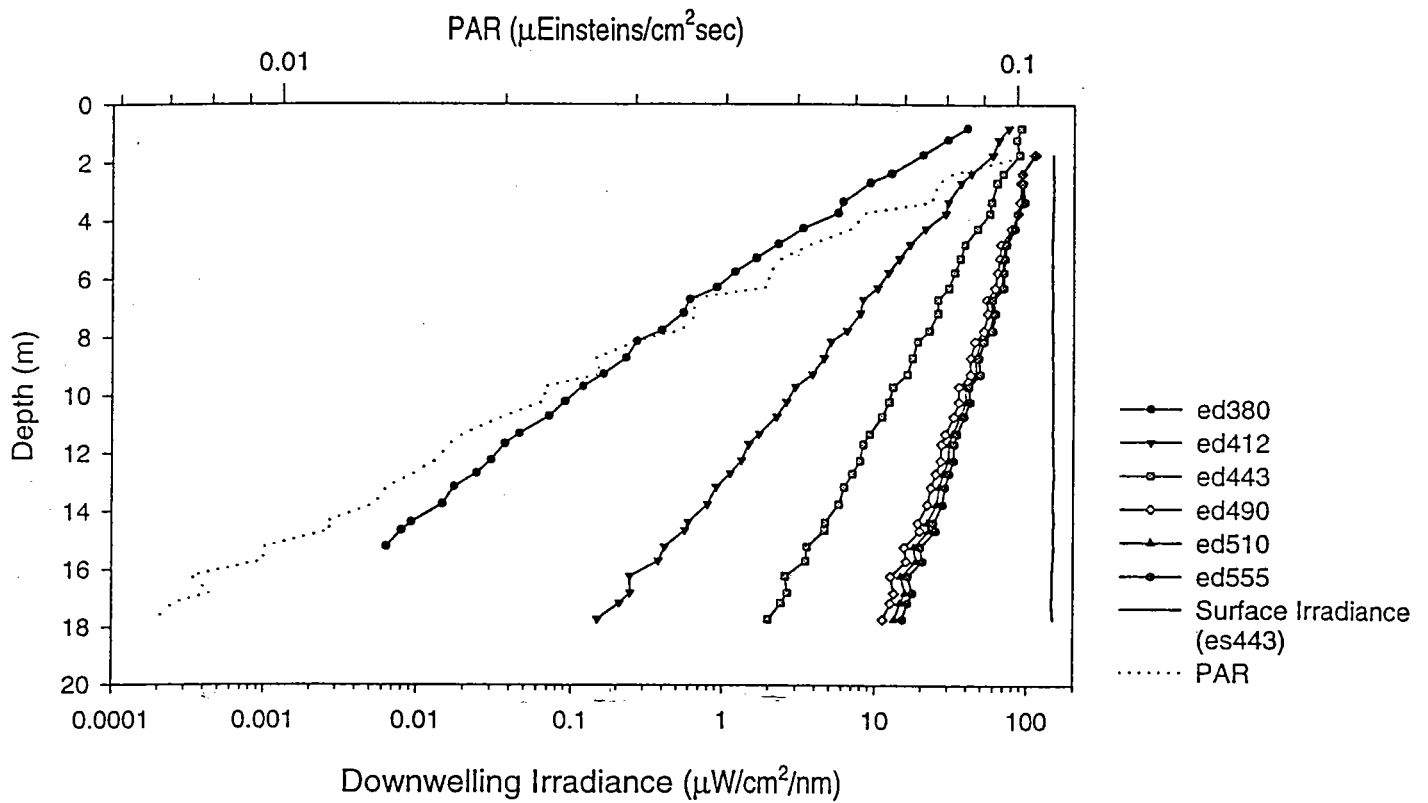
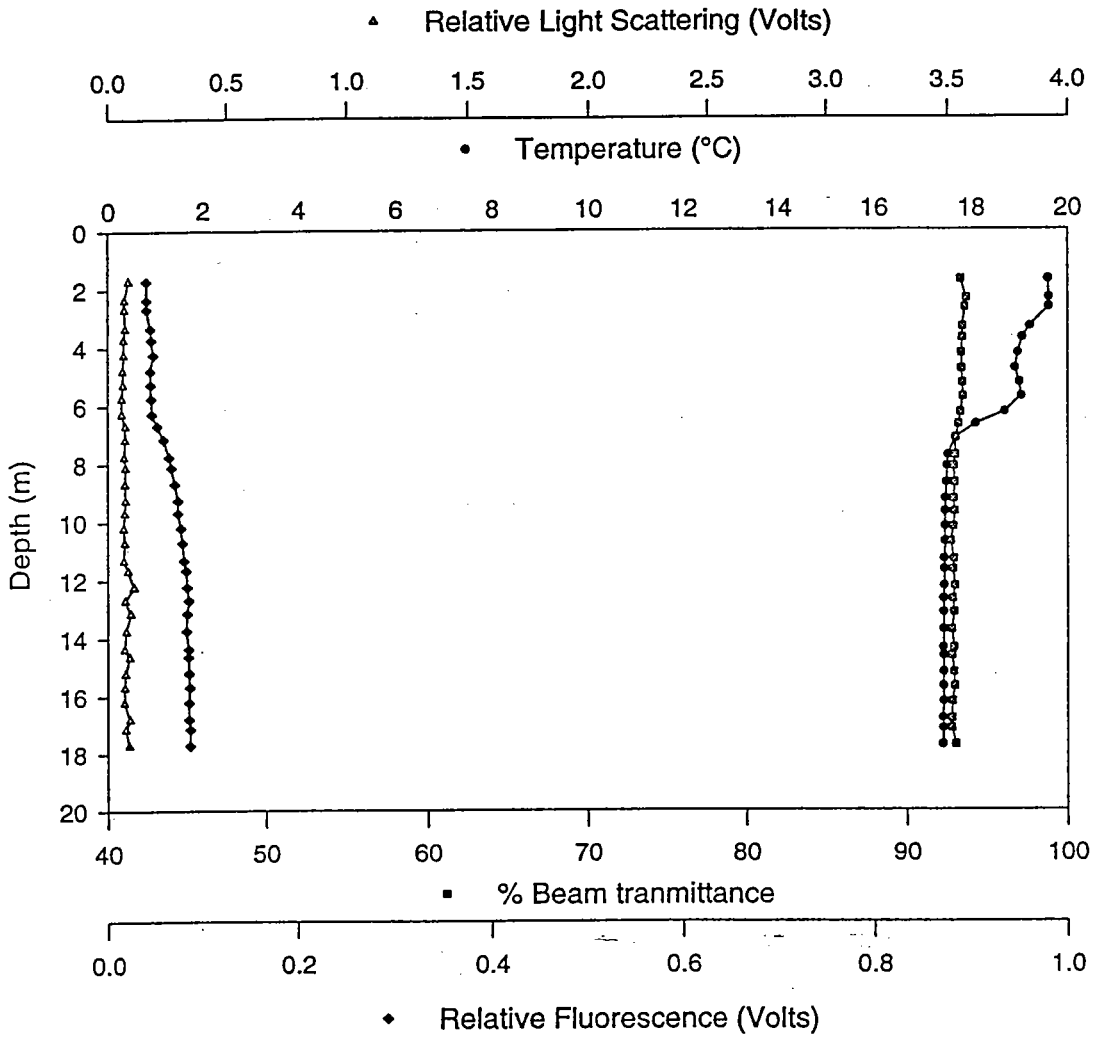

Figure A.15b - Station 2.5 Downcast



Diffuse Attenuation Coefficient ($k\lambda$)

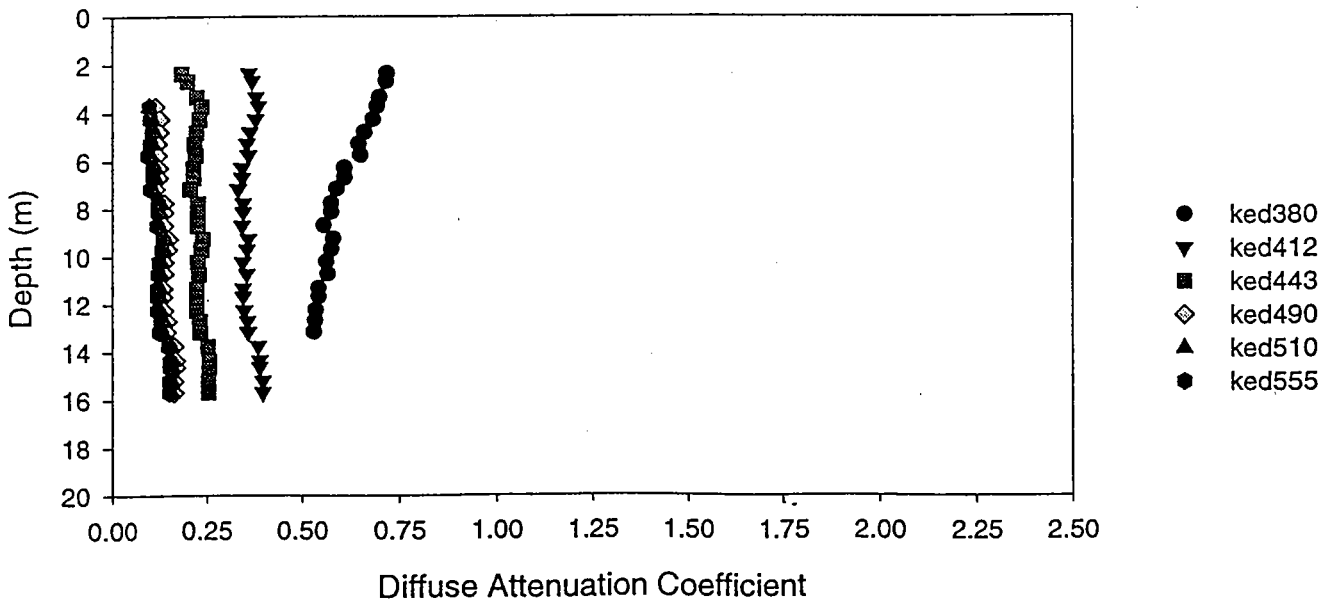

Figure A.16a - Station 2.5 Upcast

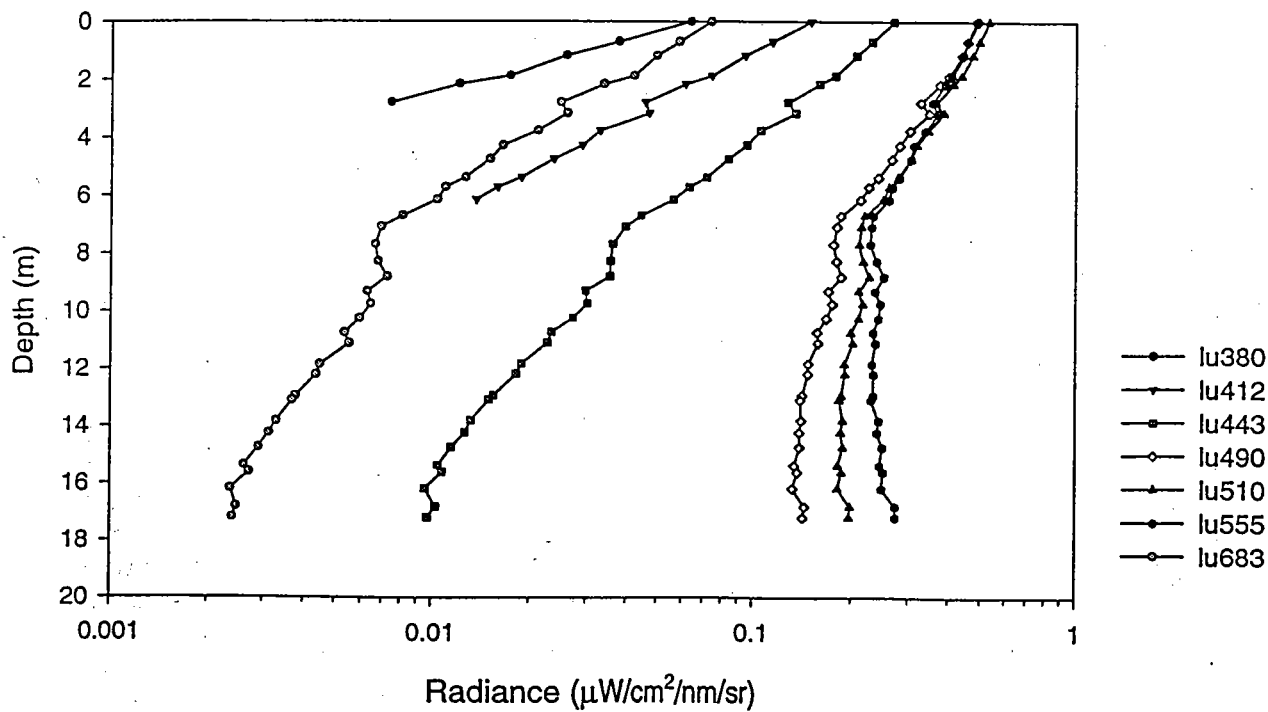
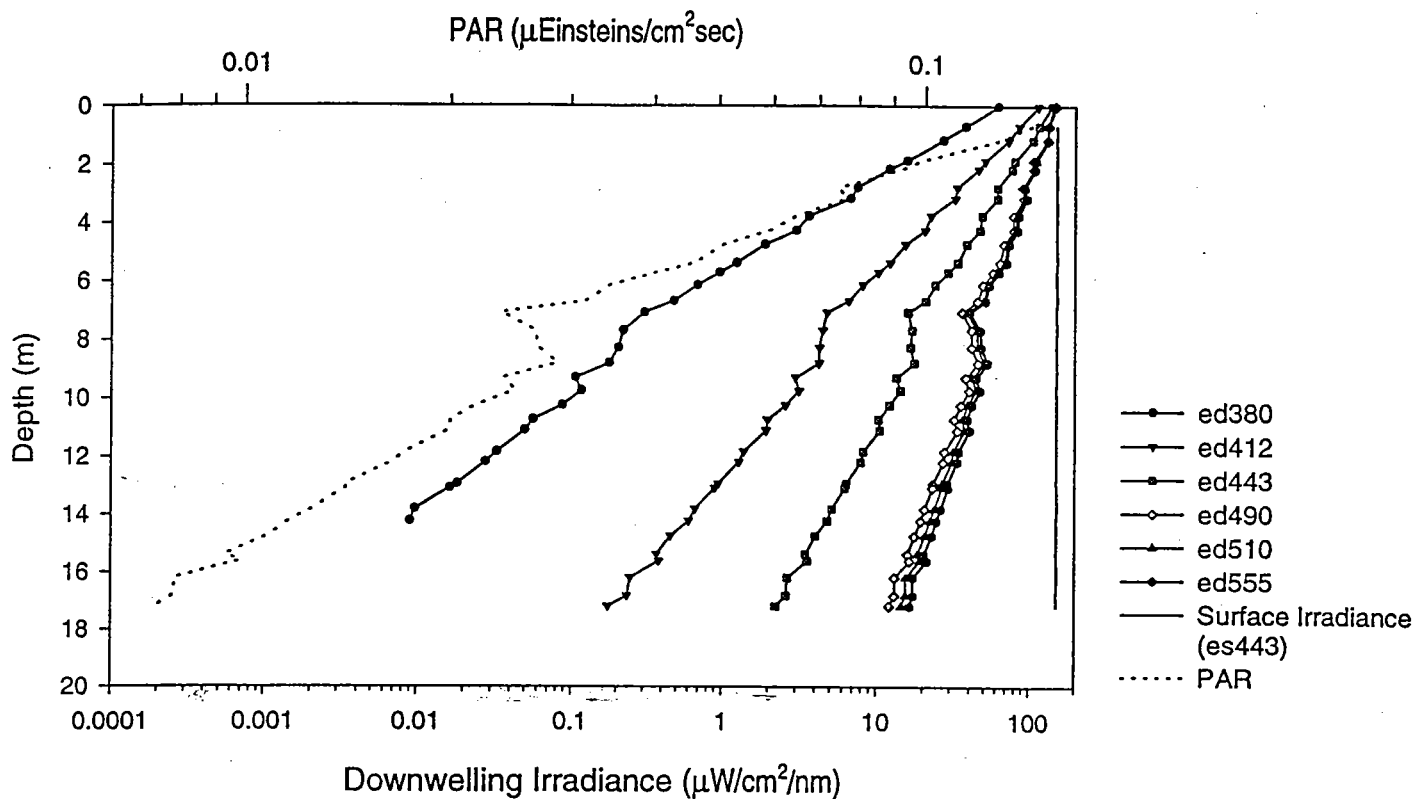
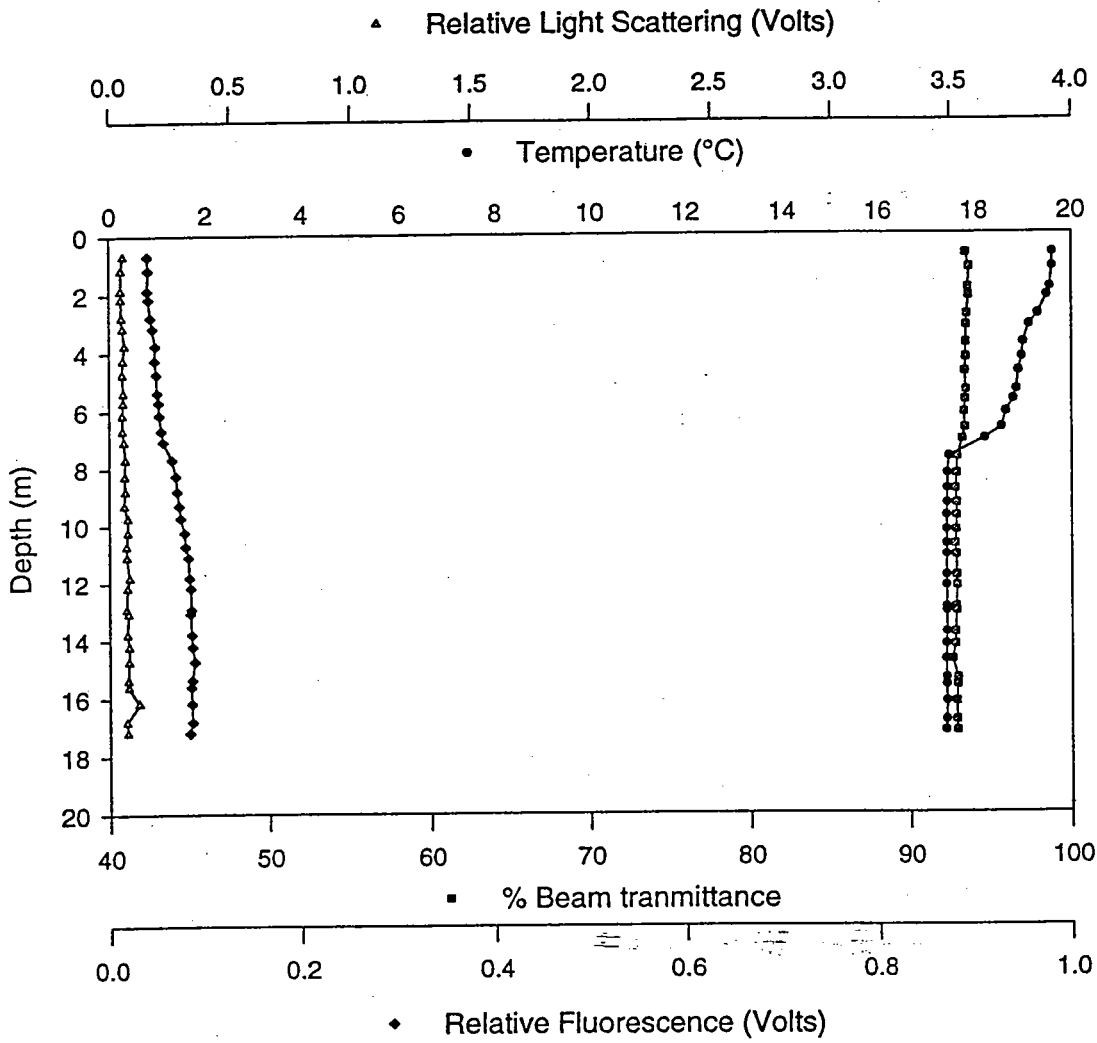

Figure A.16b - Station 2.5 Upcast



Diffuse Attenuation Coefficient (k_d)

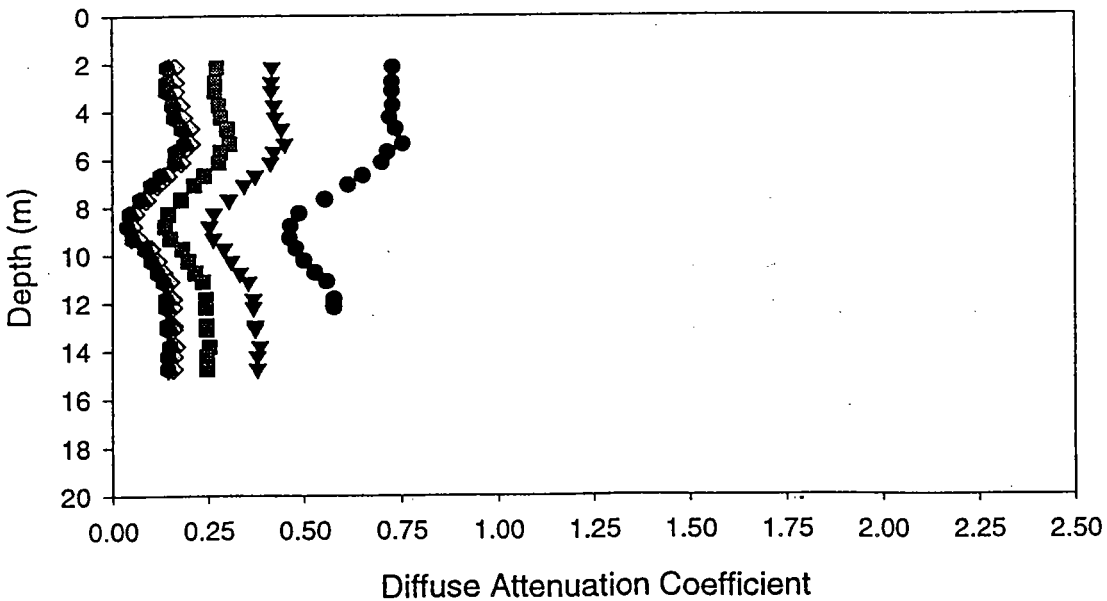

Figure A.17a - Station 2.6 Downcast

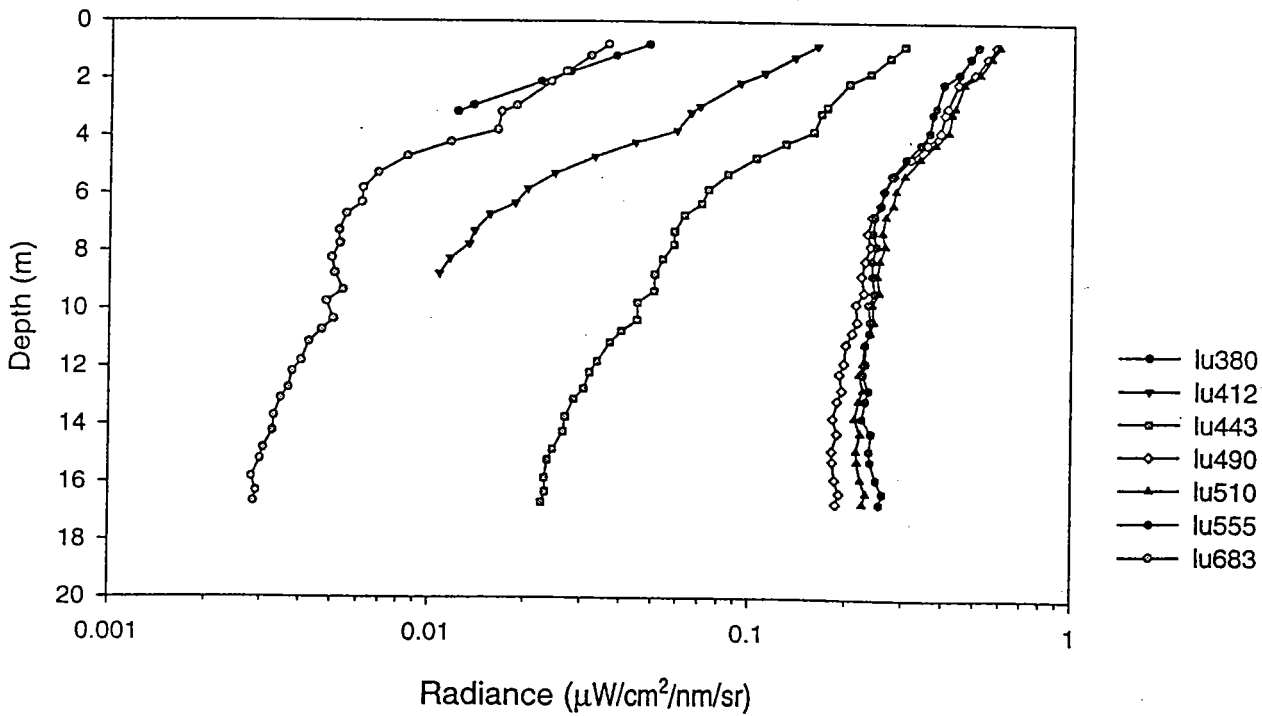
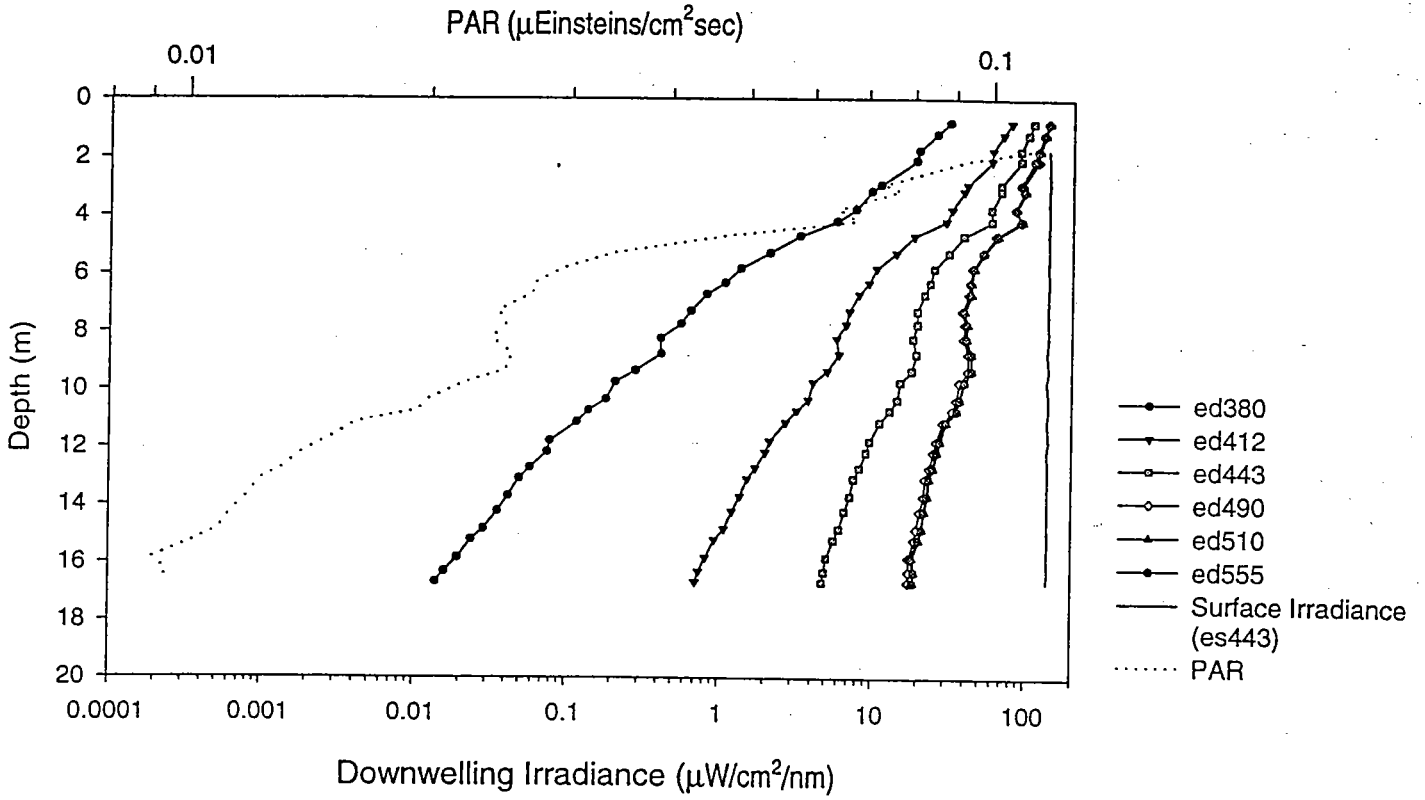
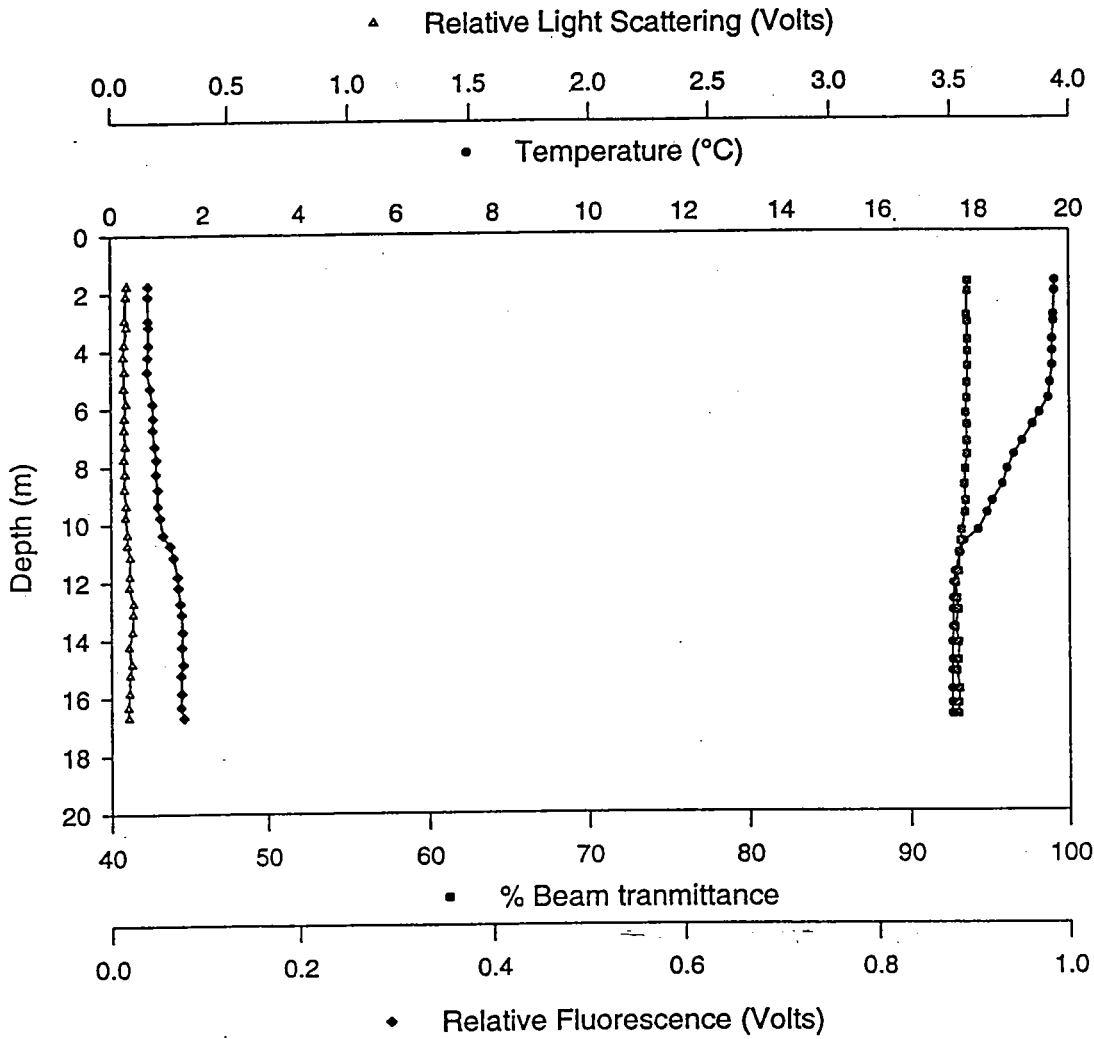

Figure A.17b - Station 2.6 Downcast



Diffuse Attenuation Coefficient ($k\lambda$)

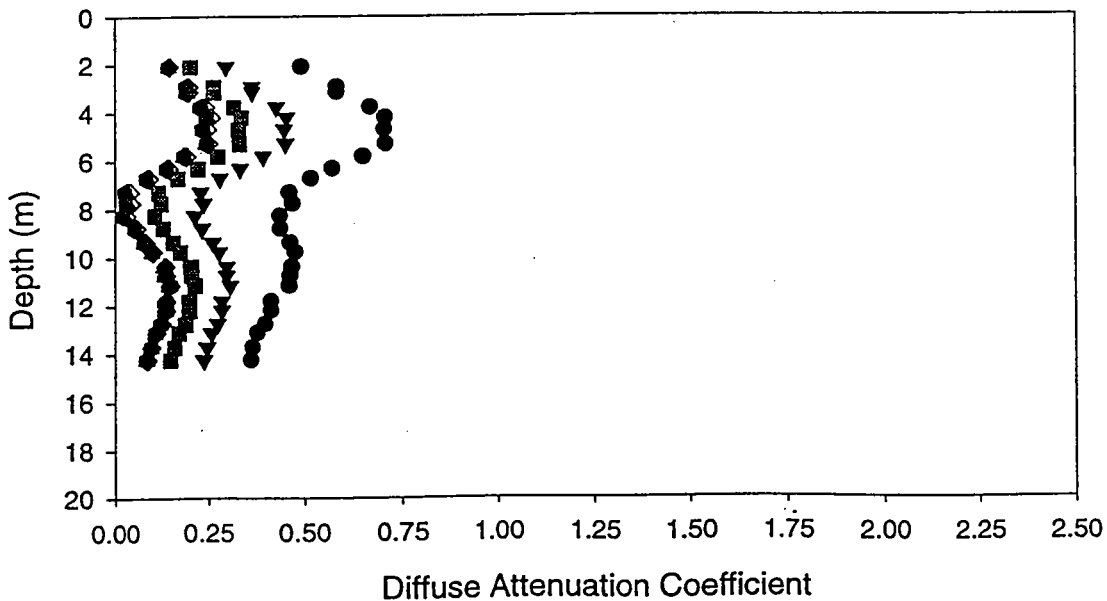

Figure A.18a - Station 2.6 Upcast

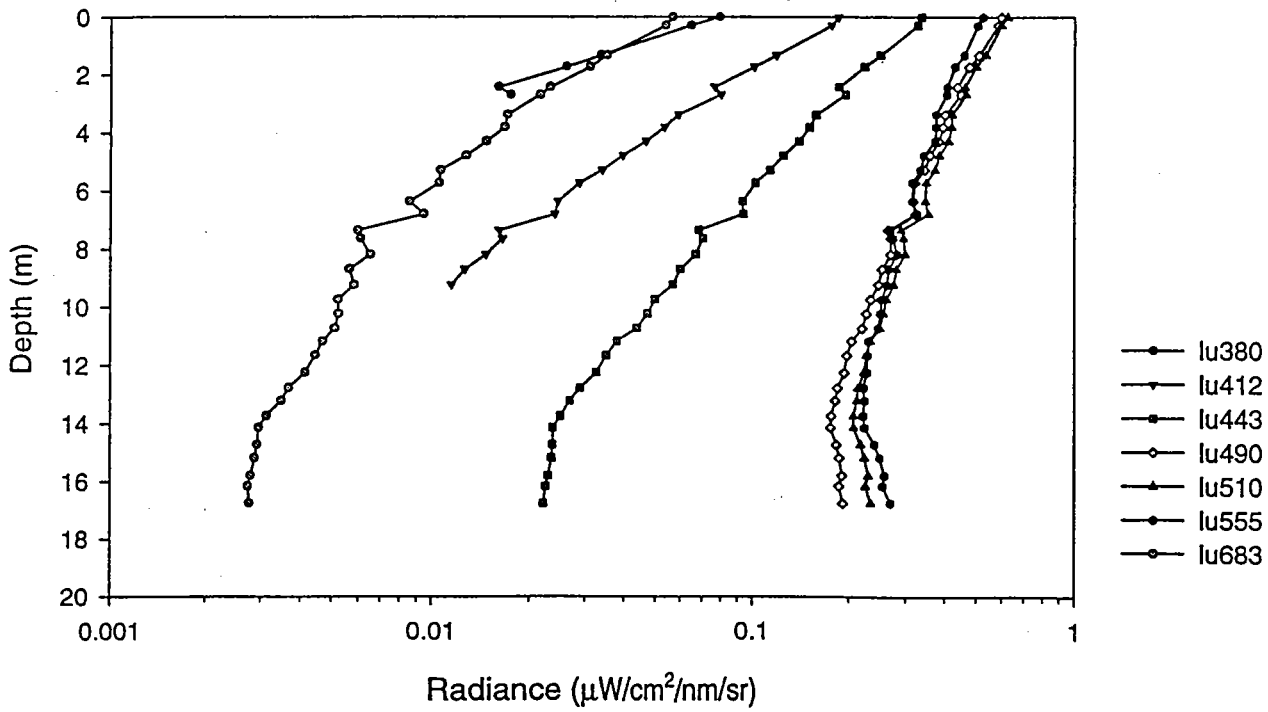
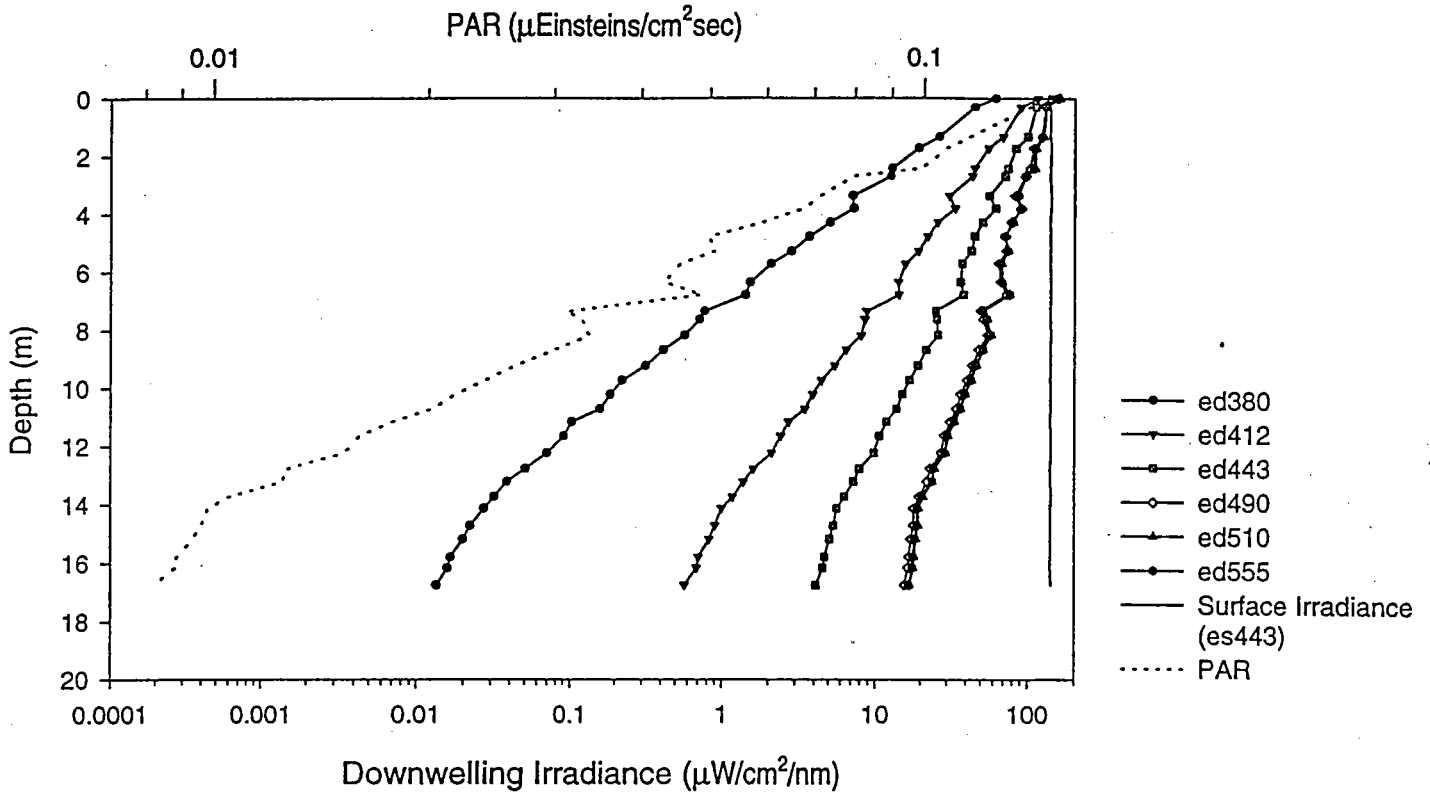
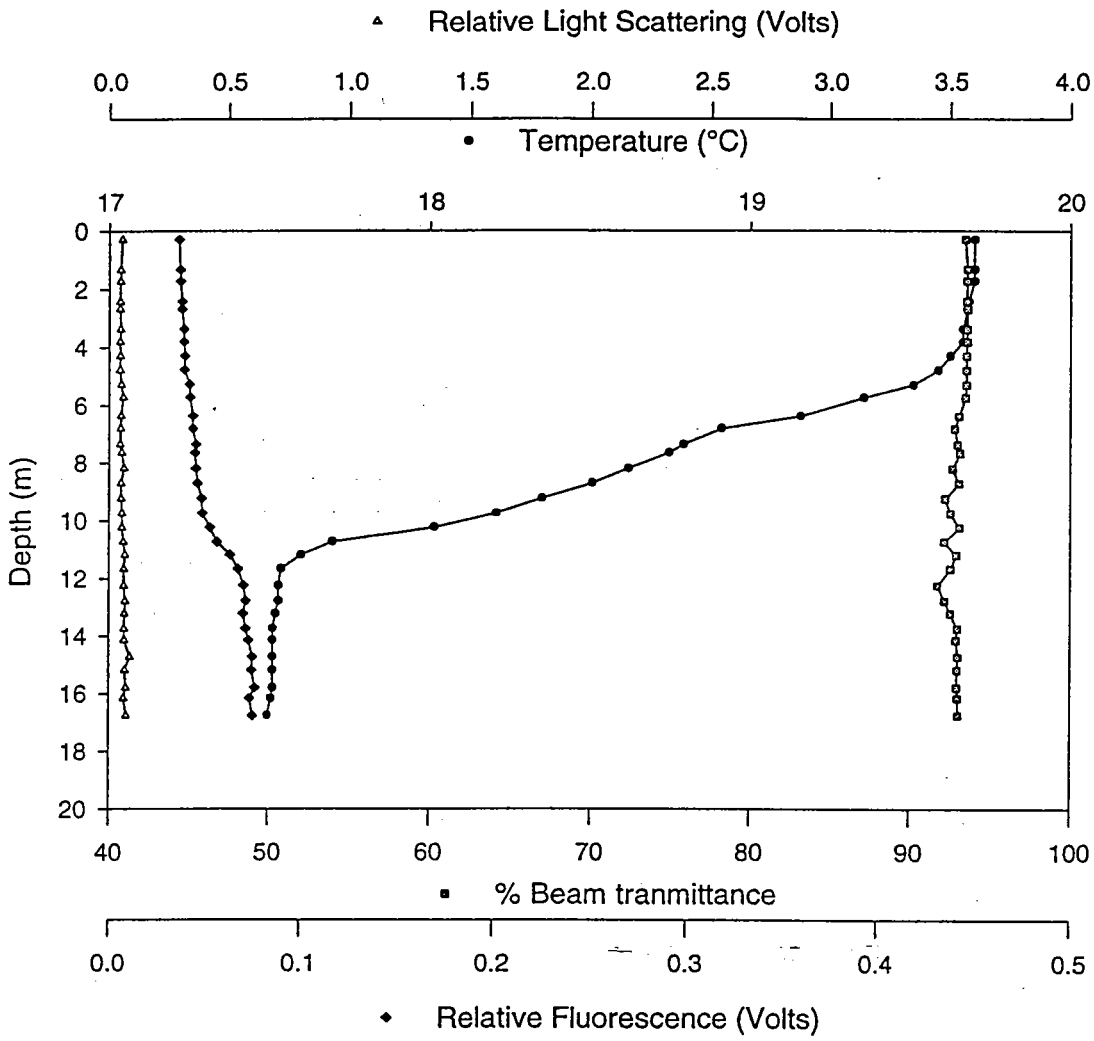

Figure A.18b - Station 2.6 Upcast



Diffuse Attenuation Coefficient ($k\lambda$)

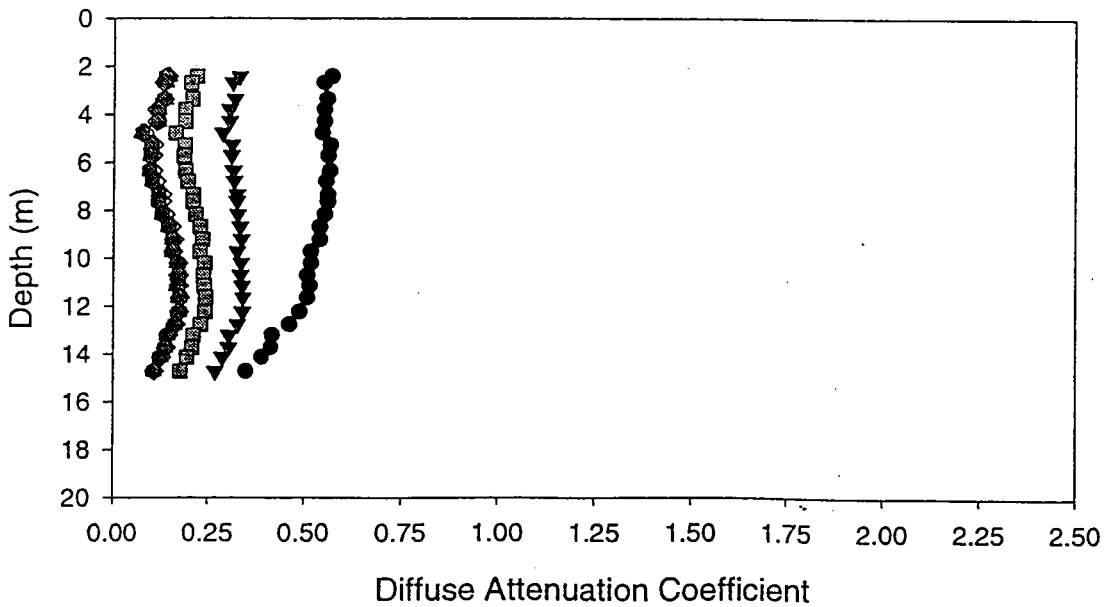

Figure A.19a - Station 2.7 Downcast

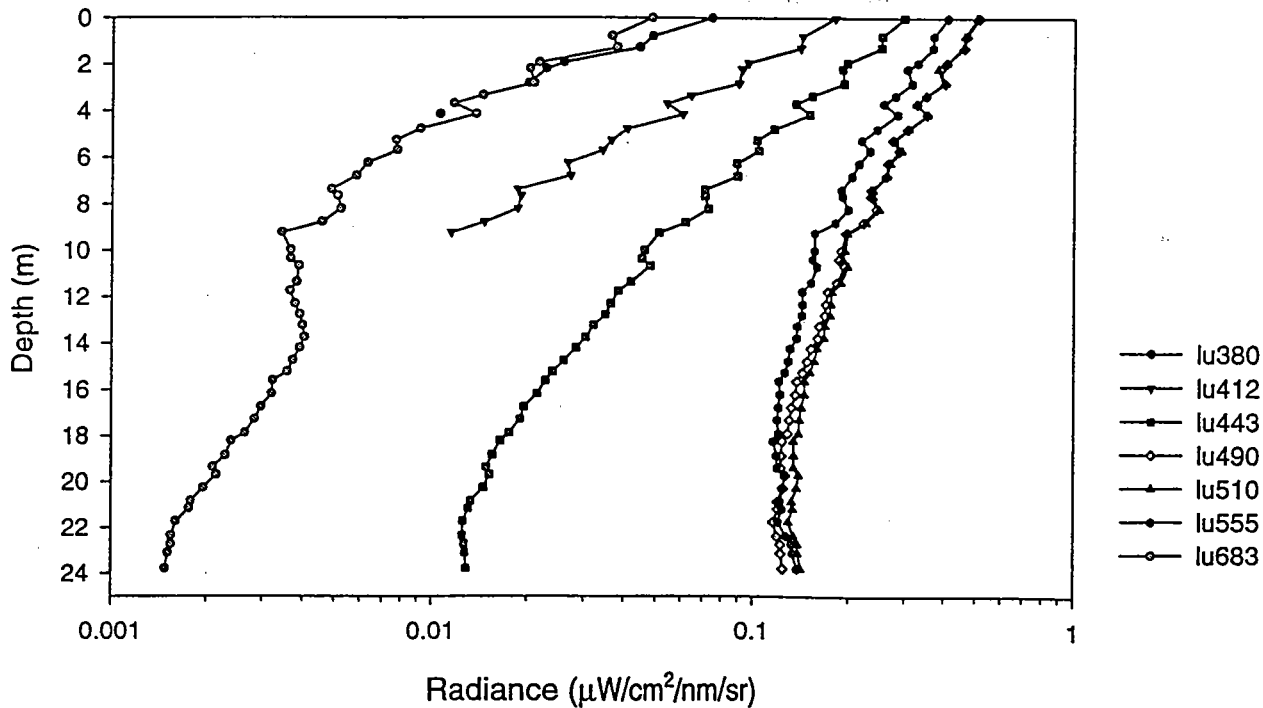
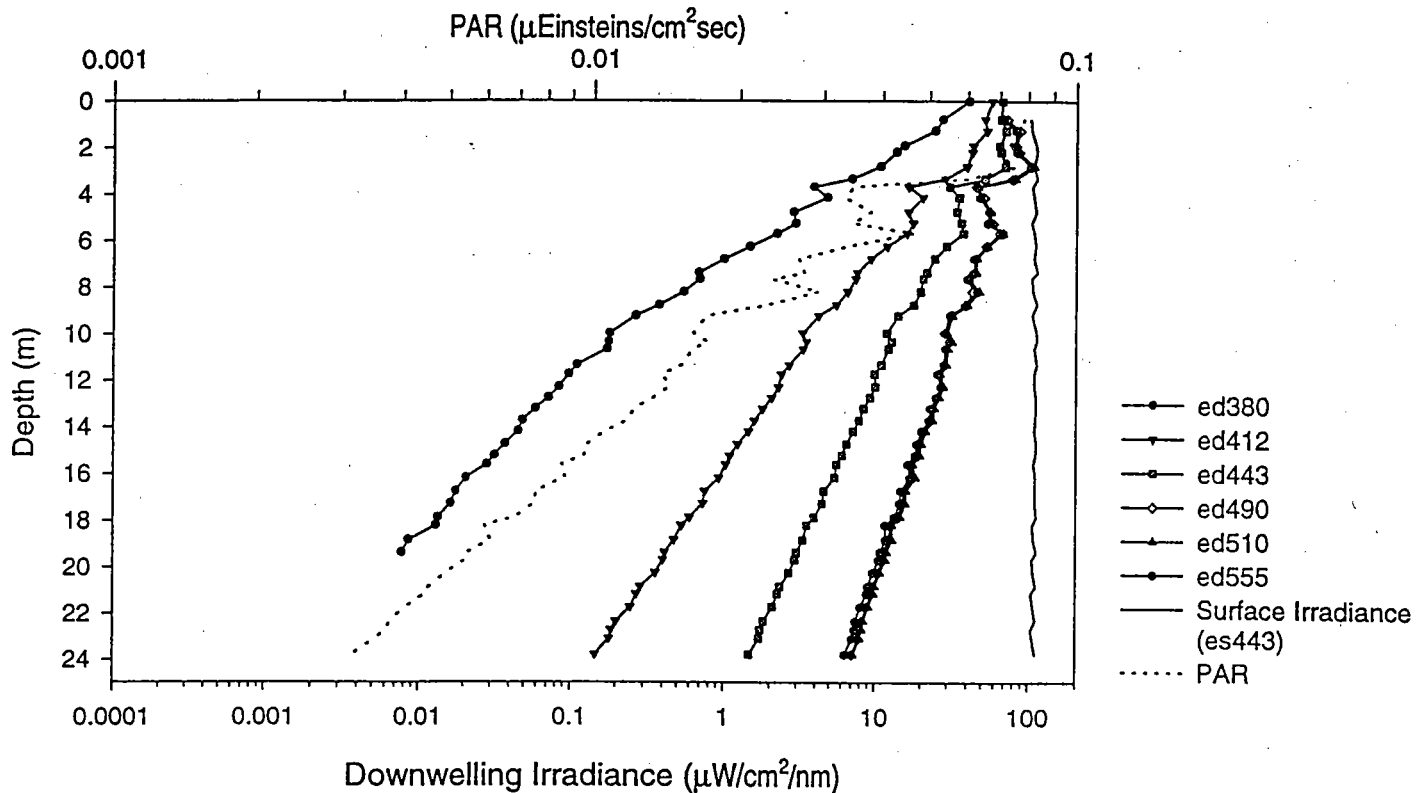
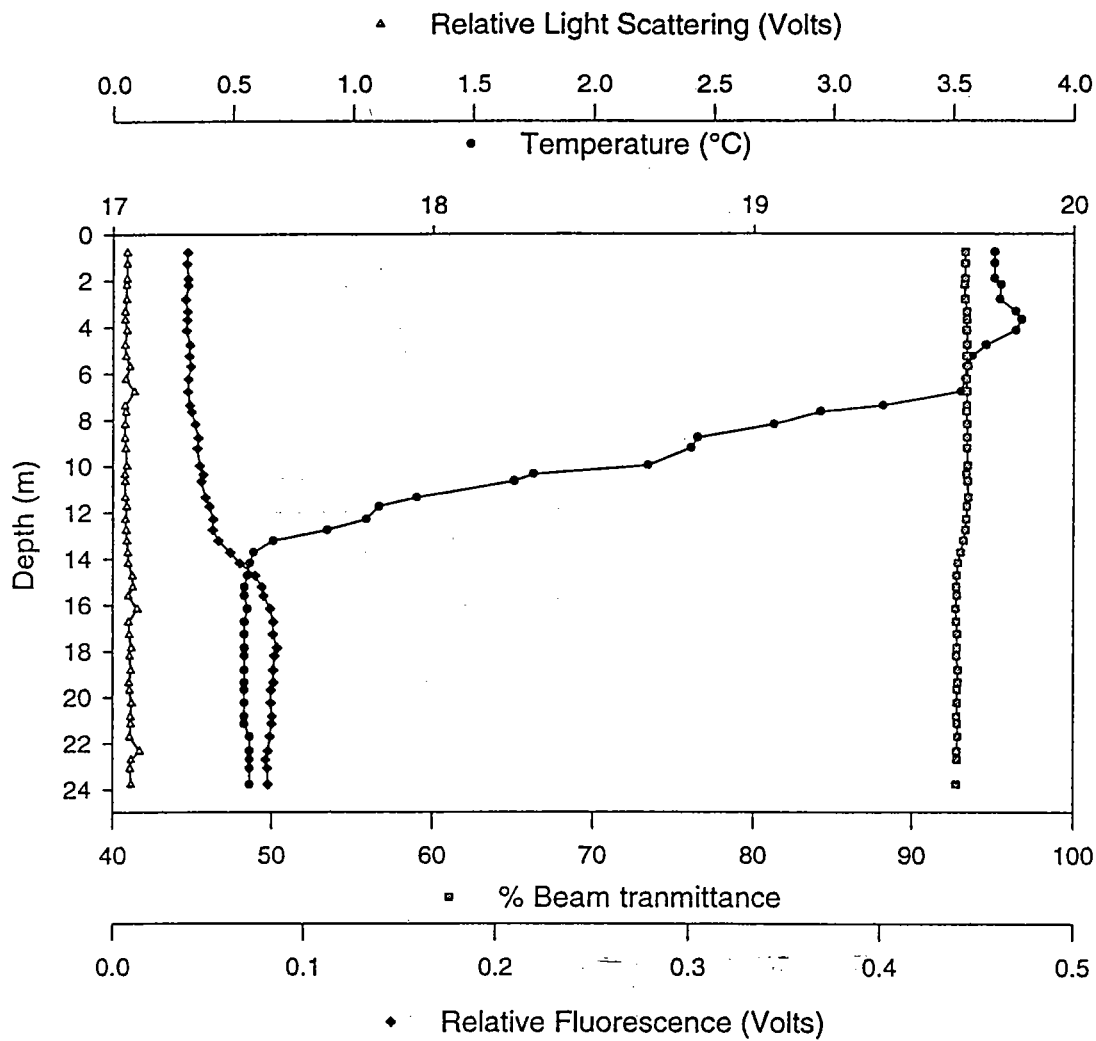

Figure A.19b - Station 2.7 Downcast



Diffuse Attenuation Coefficient ($k\lambda$)

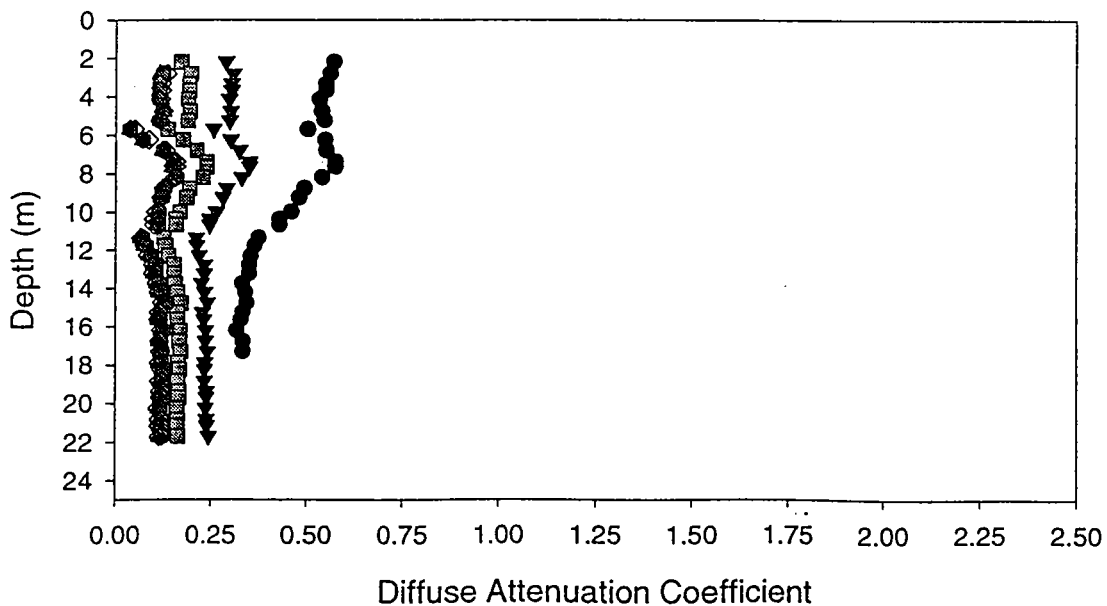

Figure A.20a - Station 2.7 Upcast

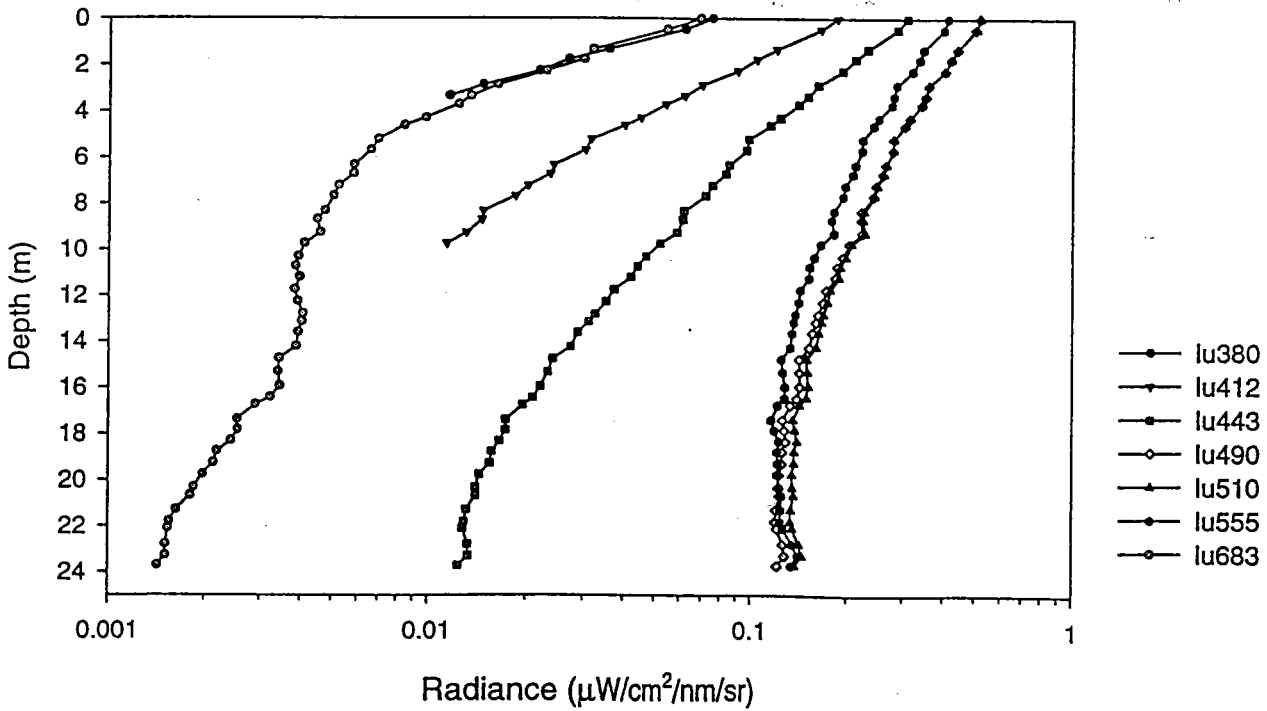
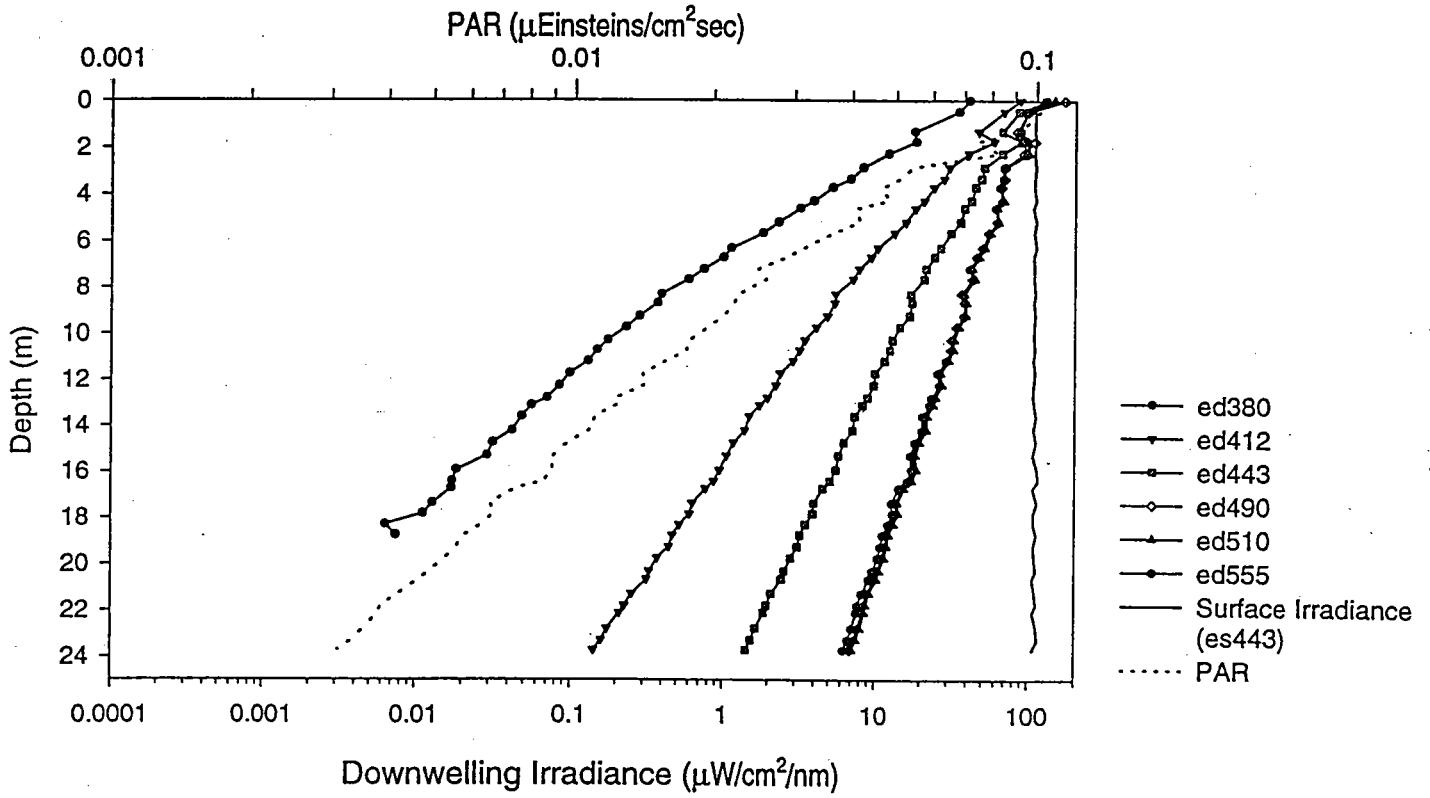
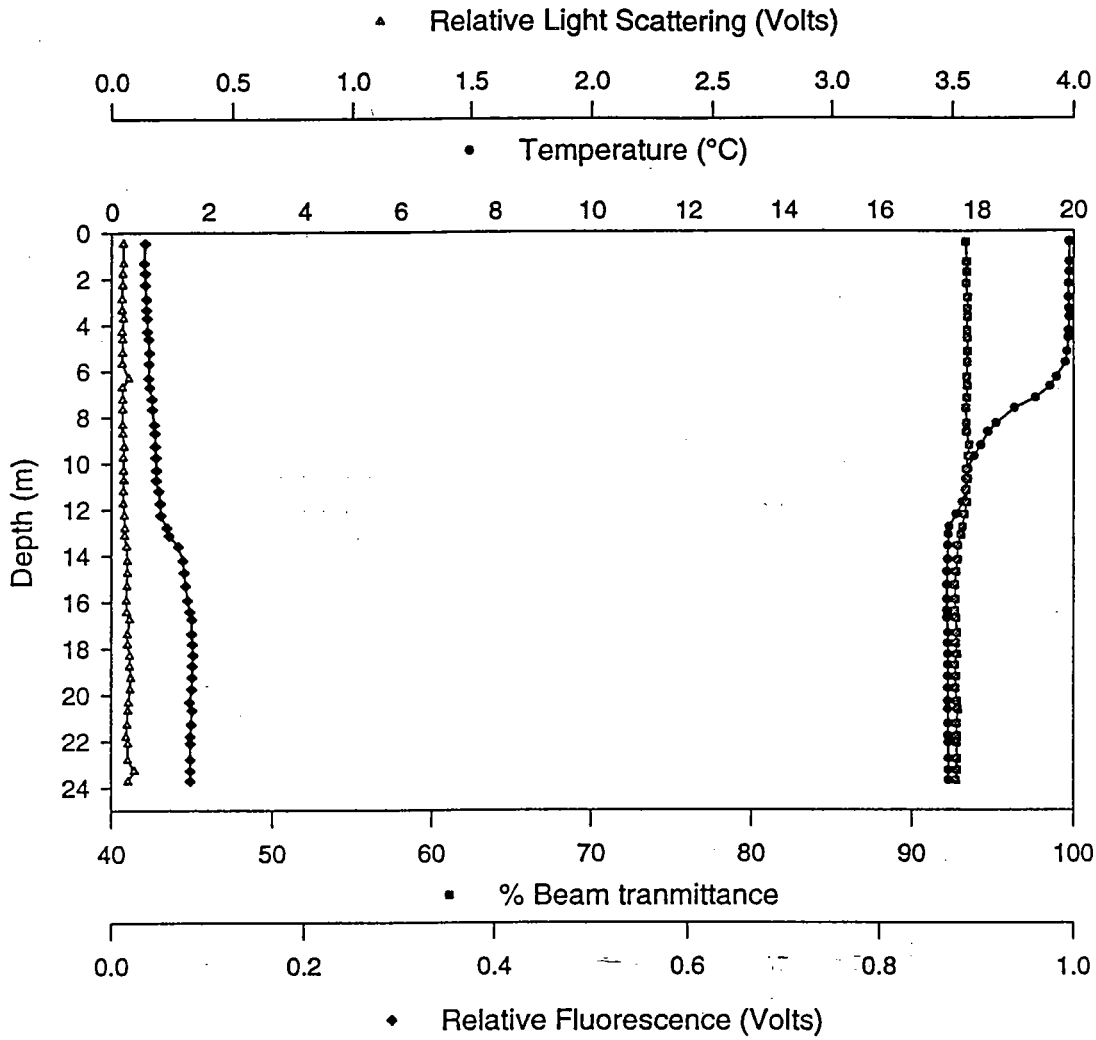

Figure A.20b - Station 2.7 Upcast



Diffuse Attenuation Coefficient (k_{λ})

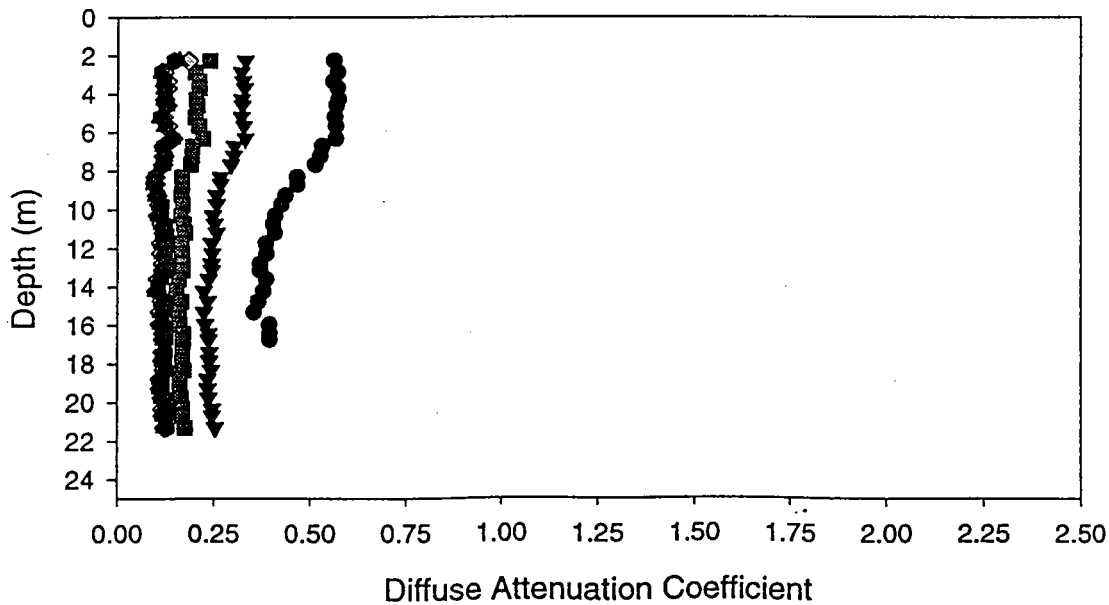

Figure A.21a - Station 3.1 Downcast

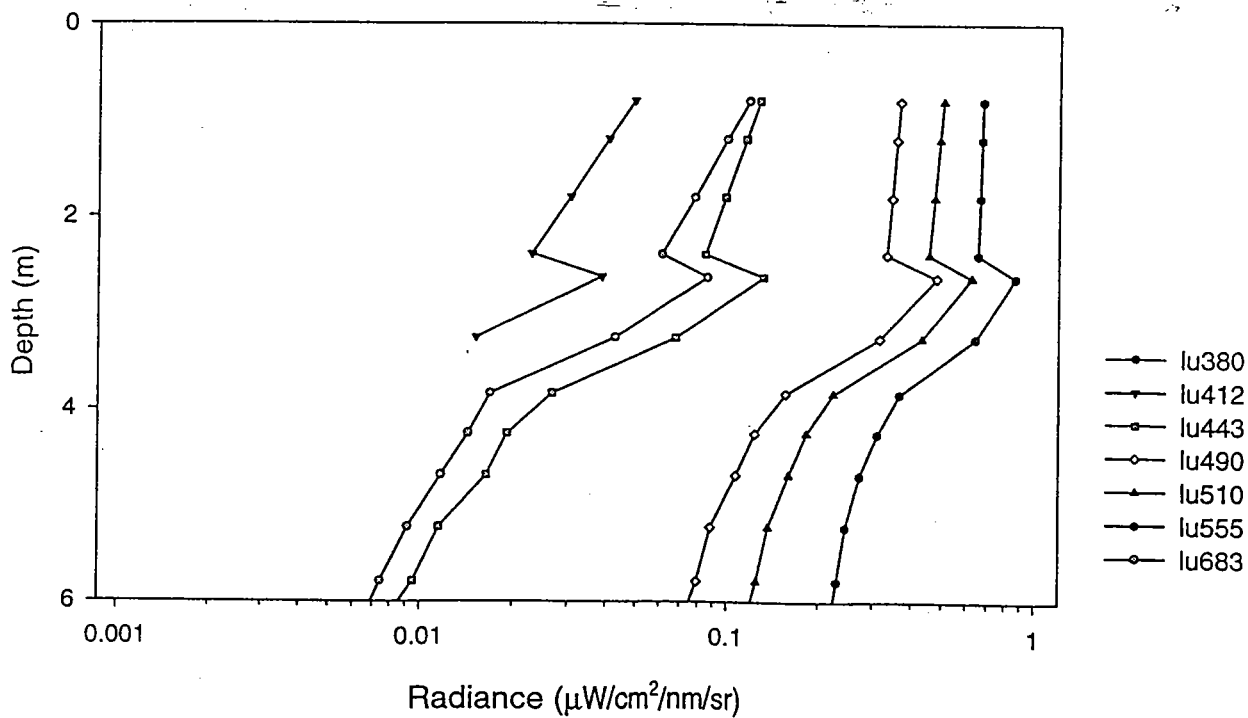
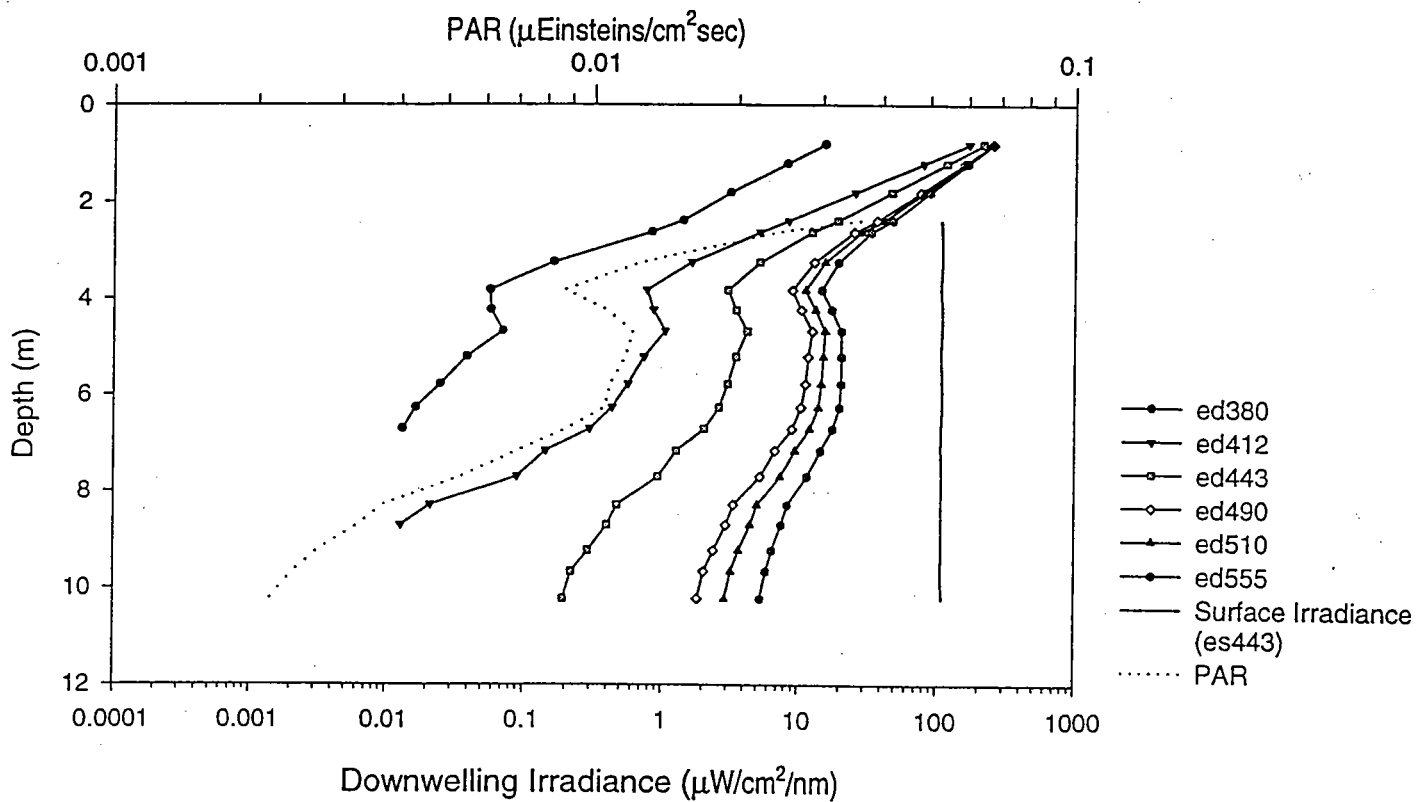
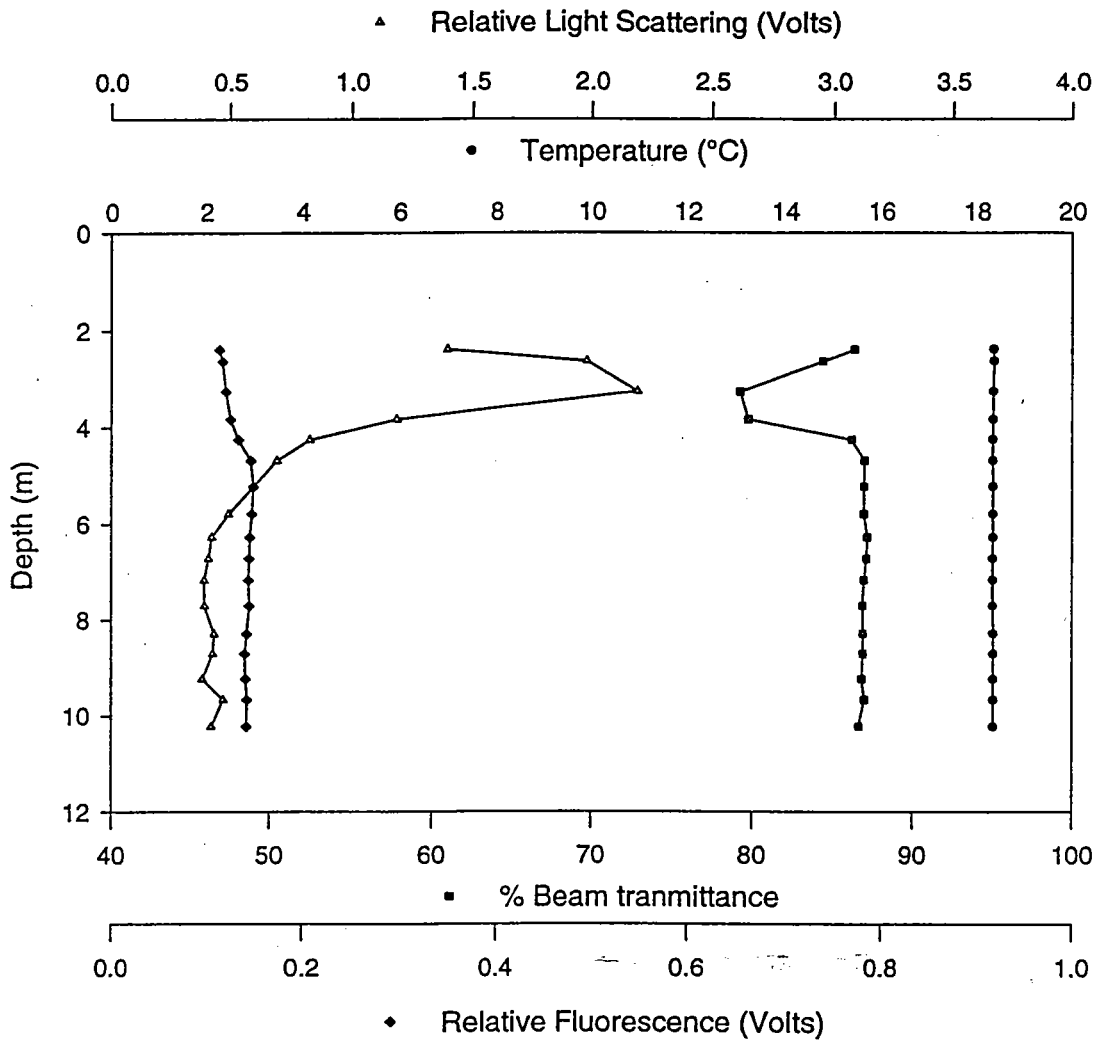

Figure A.21b - Station 3.1 Downcast



Diffuse Attenuation Coefficient ($k\lambda$)

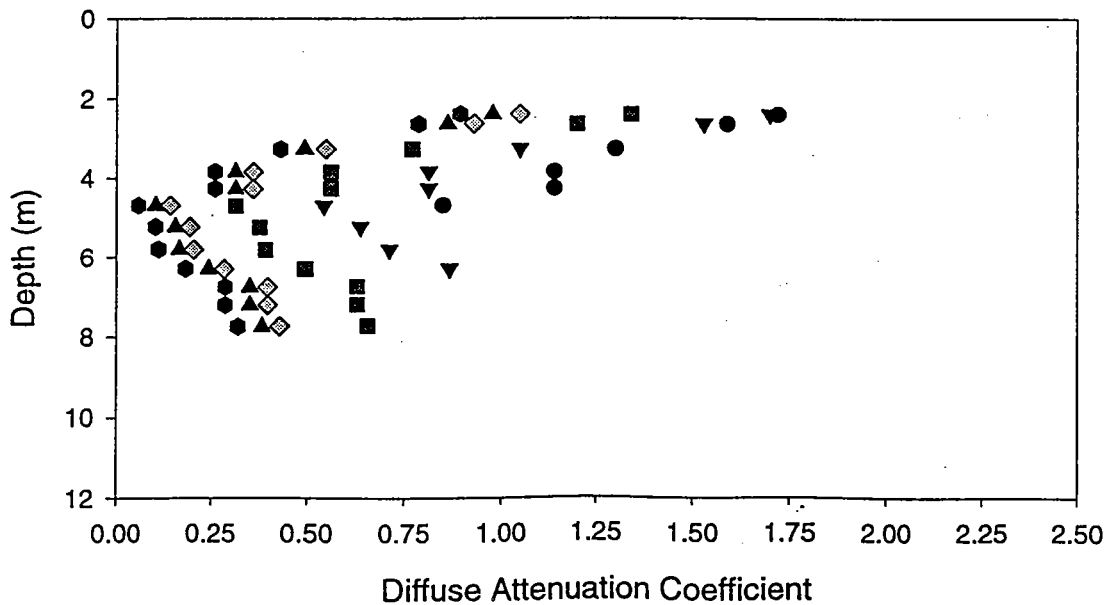

Figure A.22a - Station 3.1 Upcast

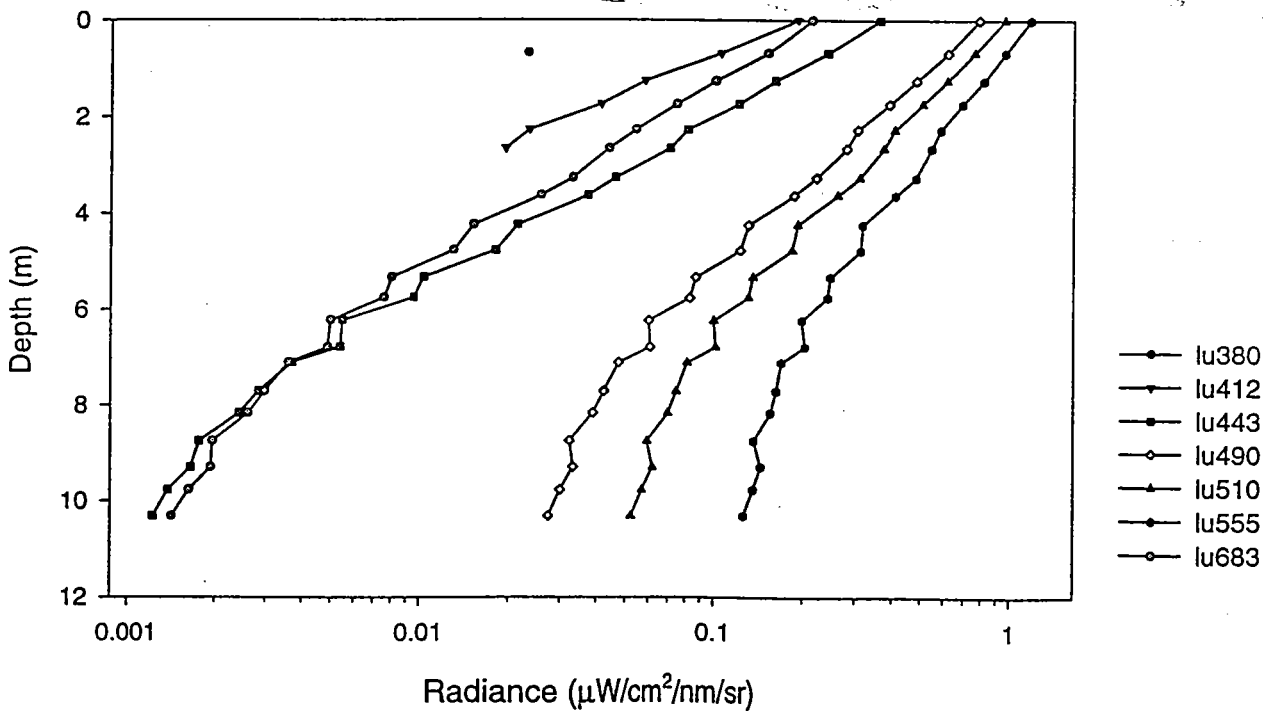
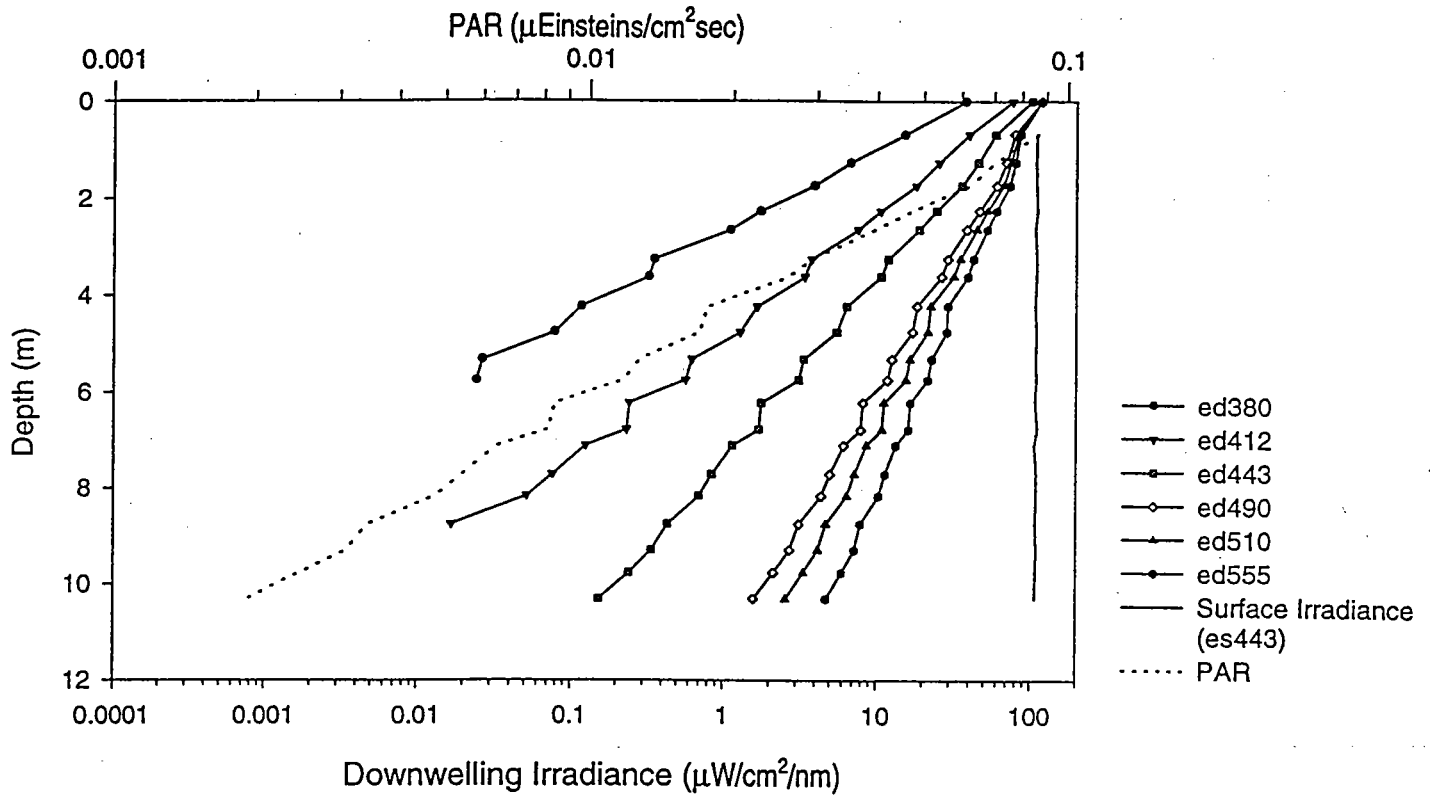
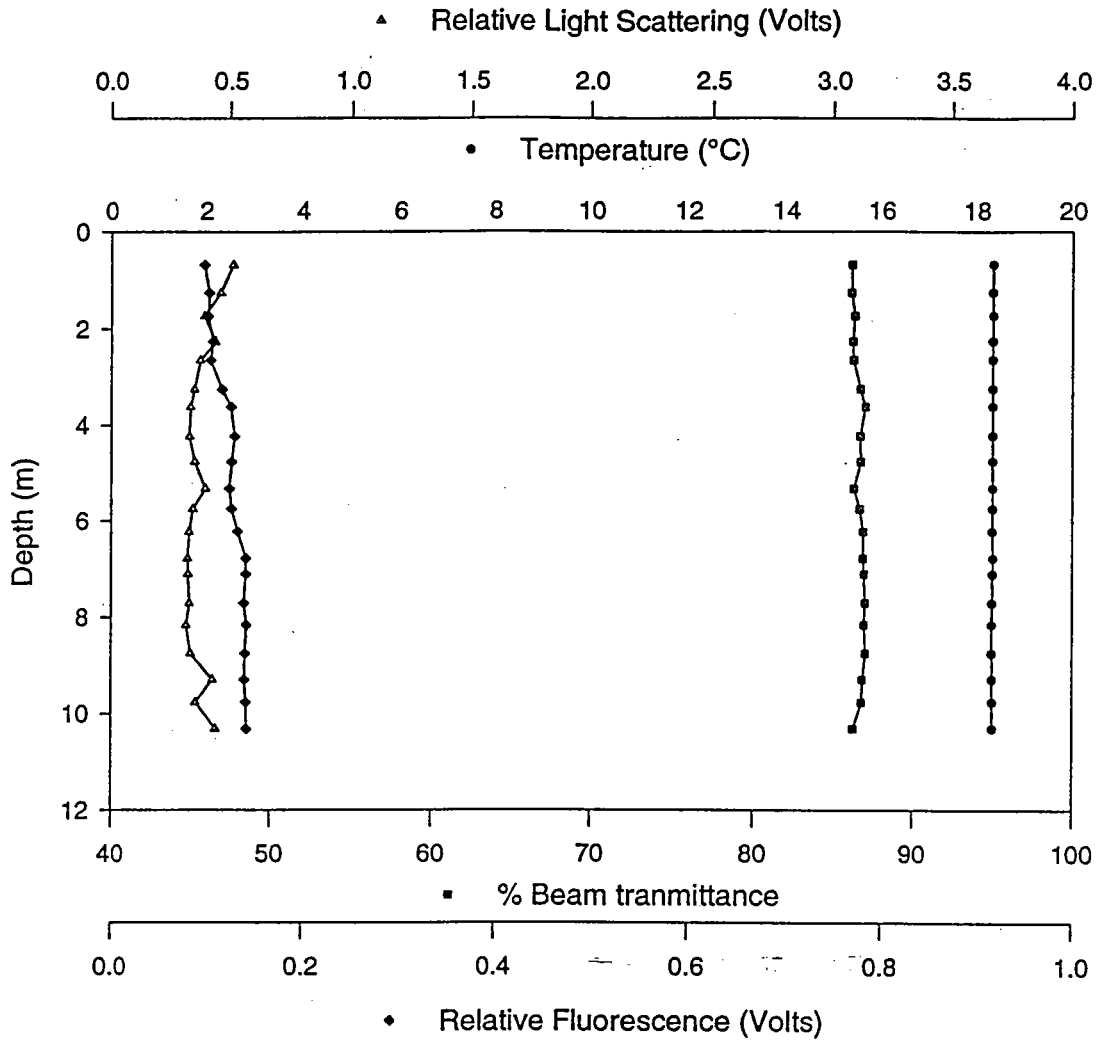

Figure A.22b - Station 3.1 Upcast



Diffuse Attenuation Coefficient (k_λ)

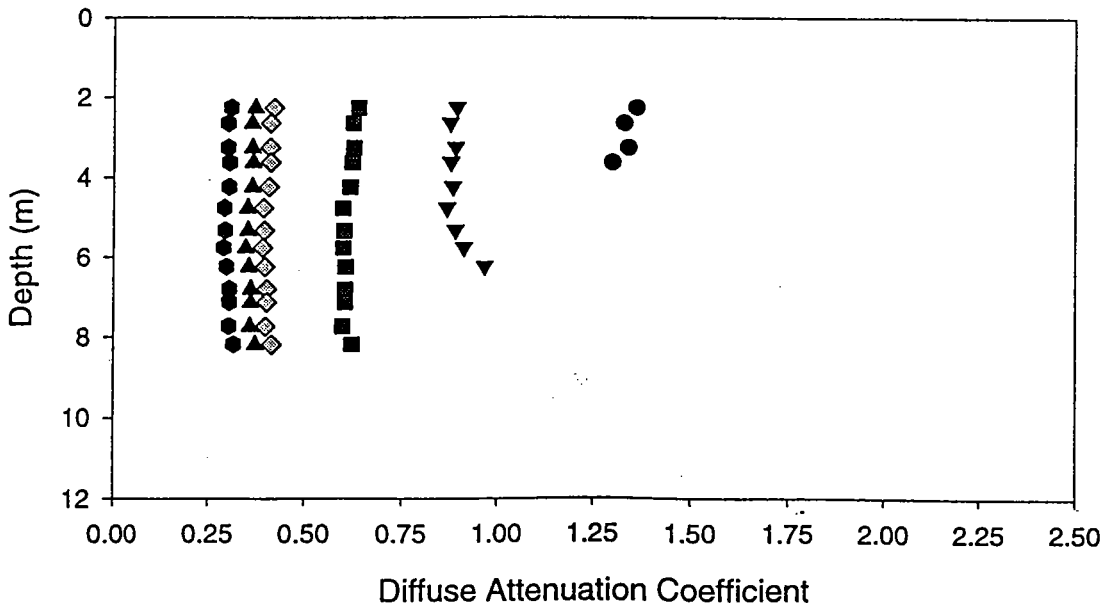

Figure A.23a - Station 3.2 Downcast

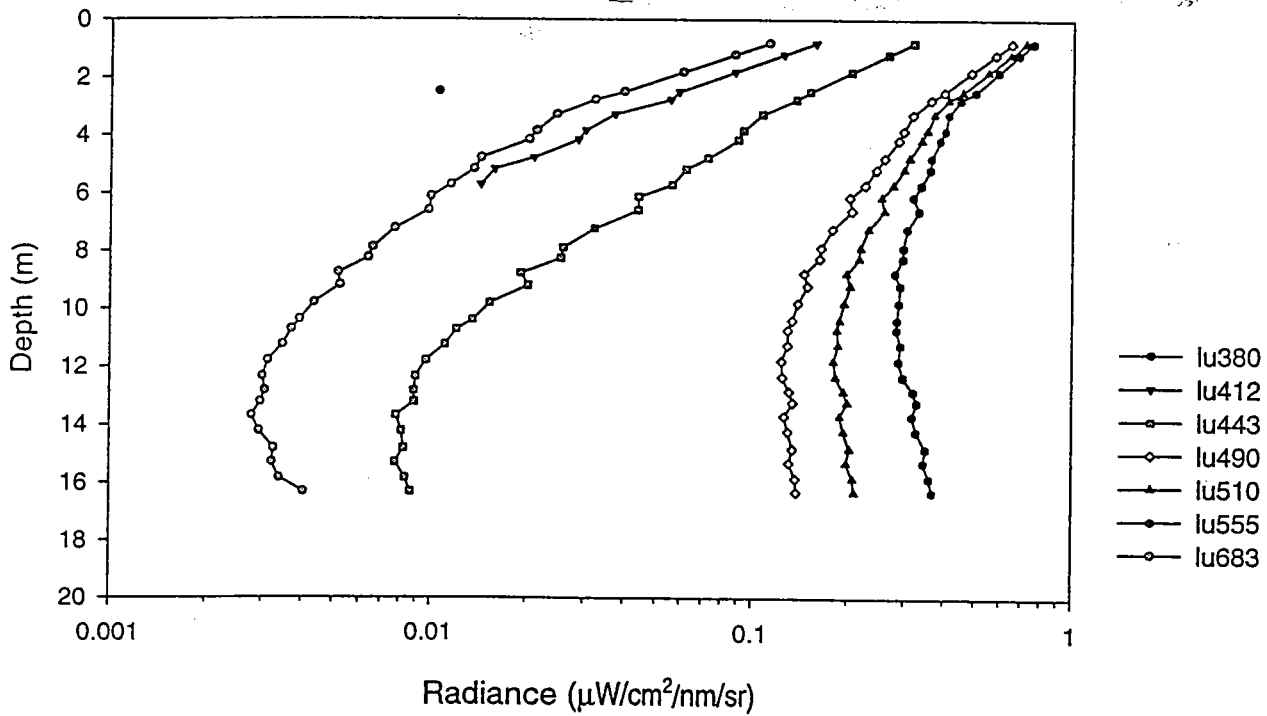
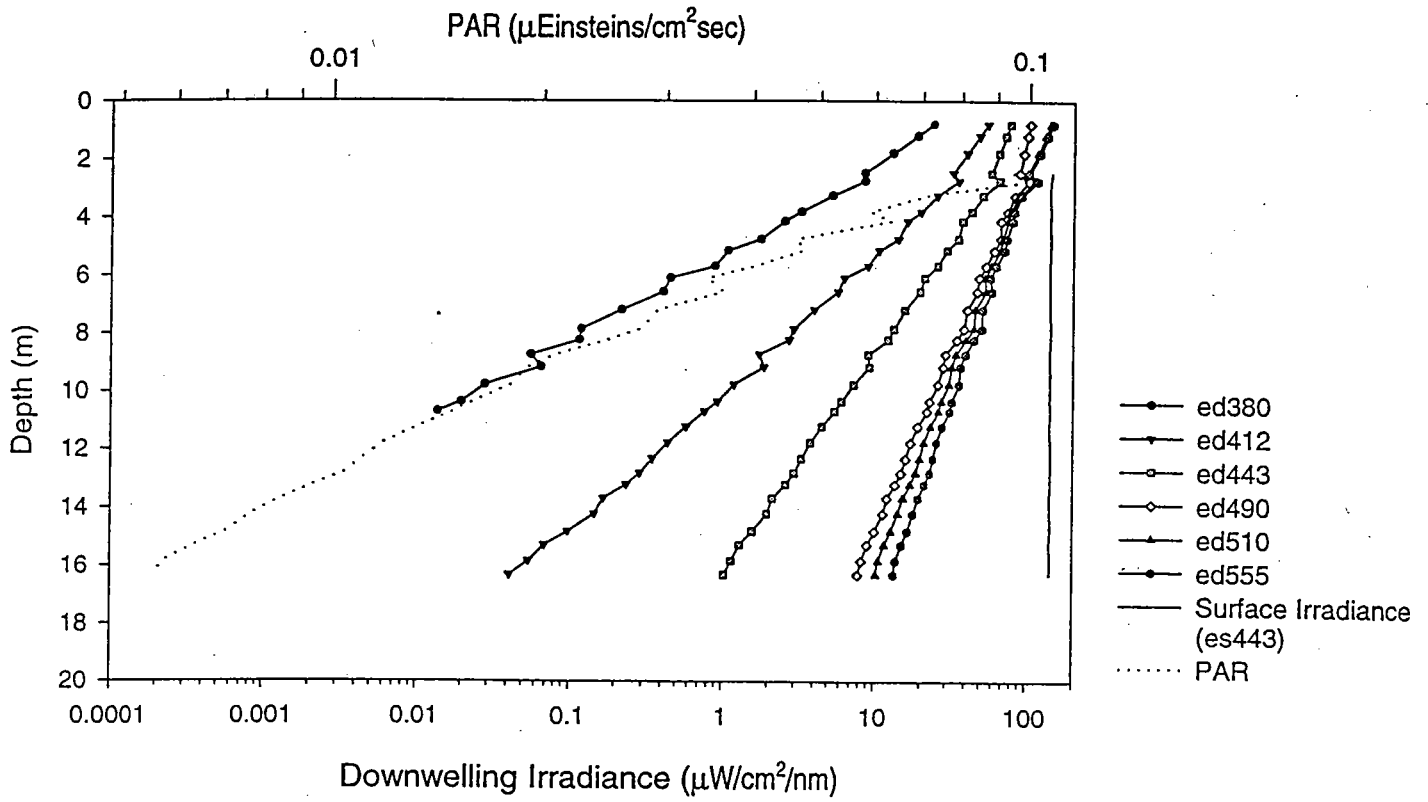
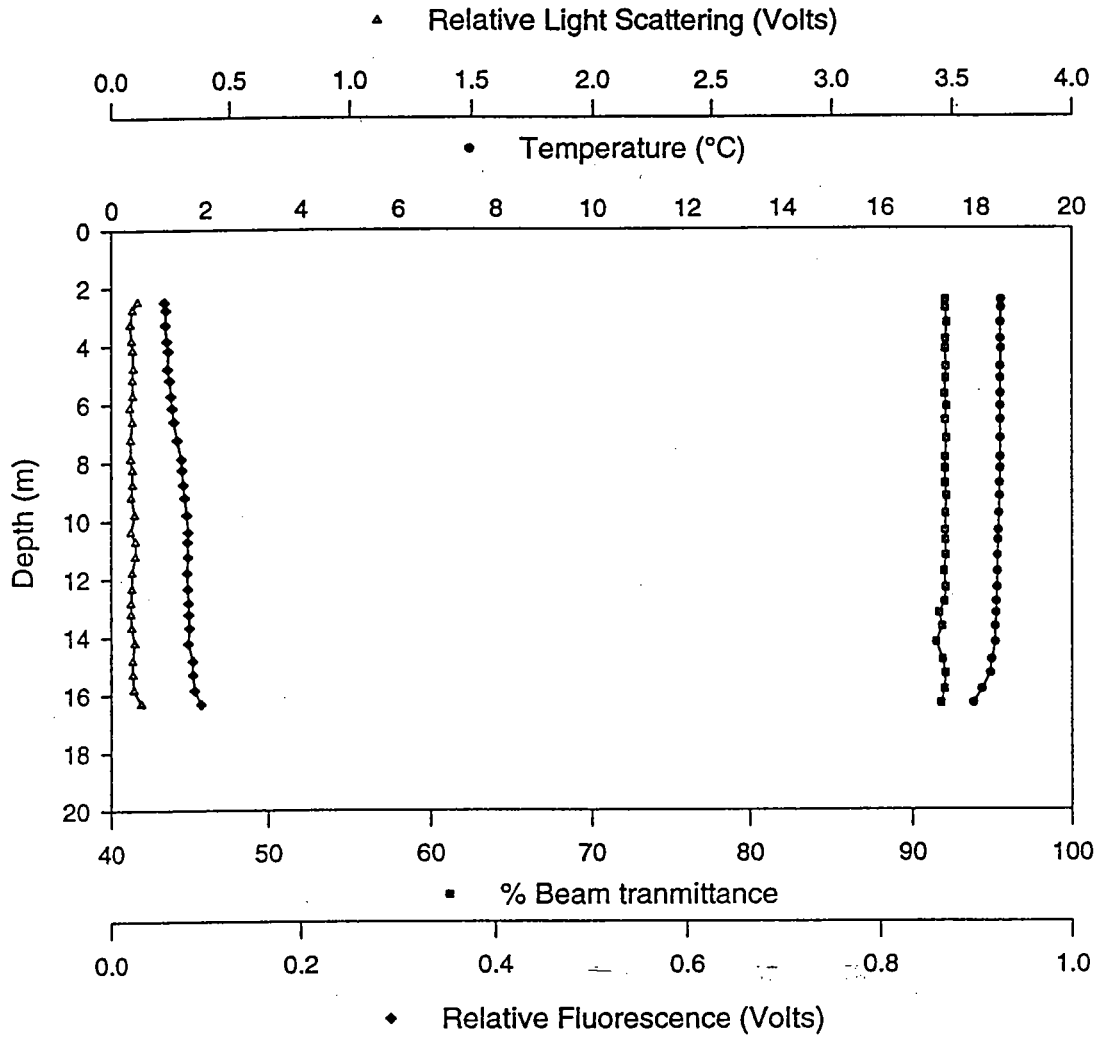

Figure A.23b - Station 3.2 Downcast



Diffuse Attenuation Coefficient ($k\lambda$)

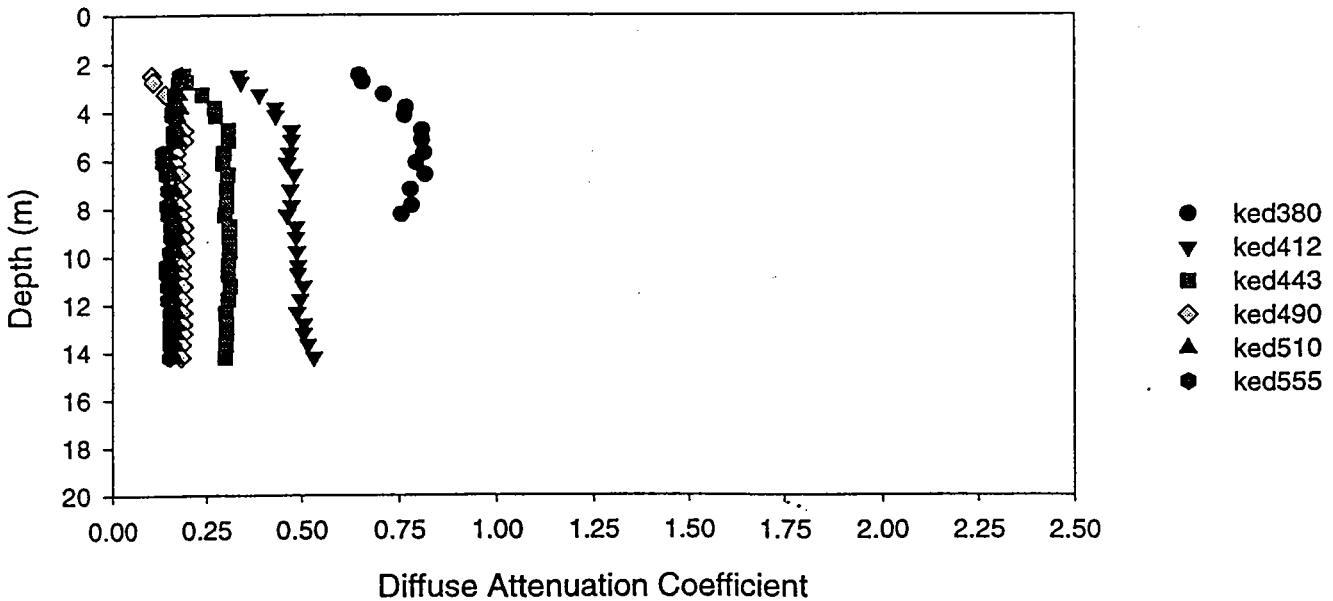

Figure A.24a - Station 3.2 Upcast

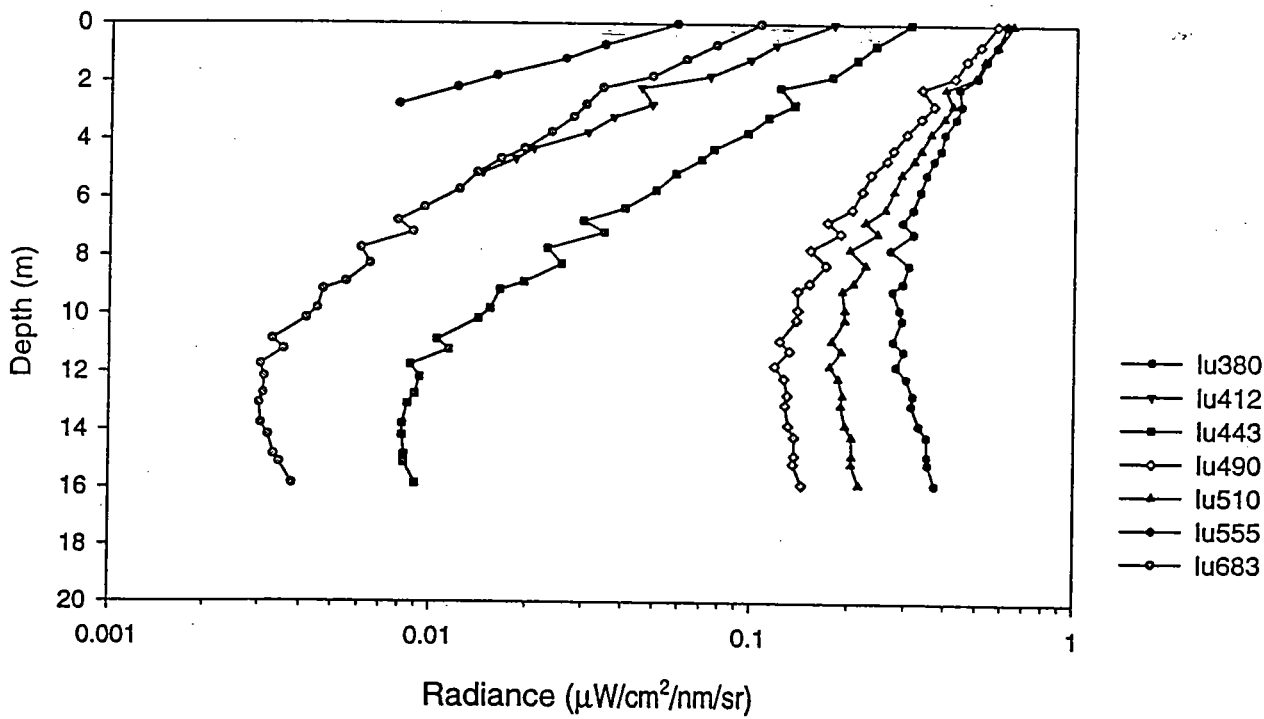
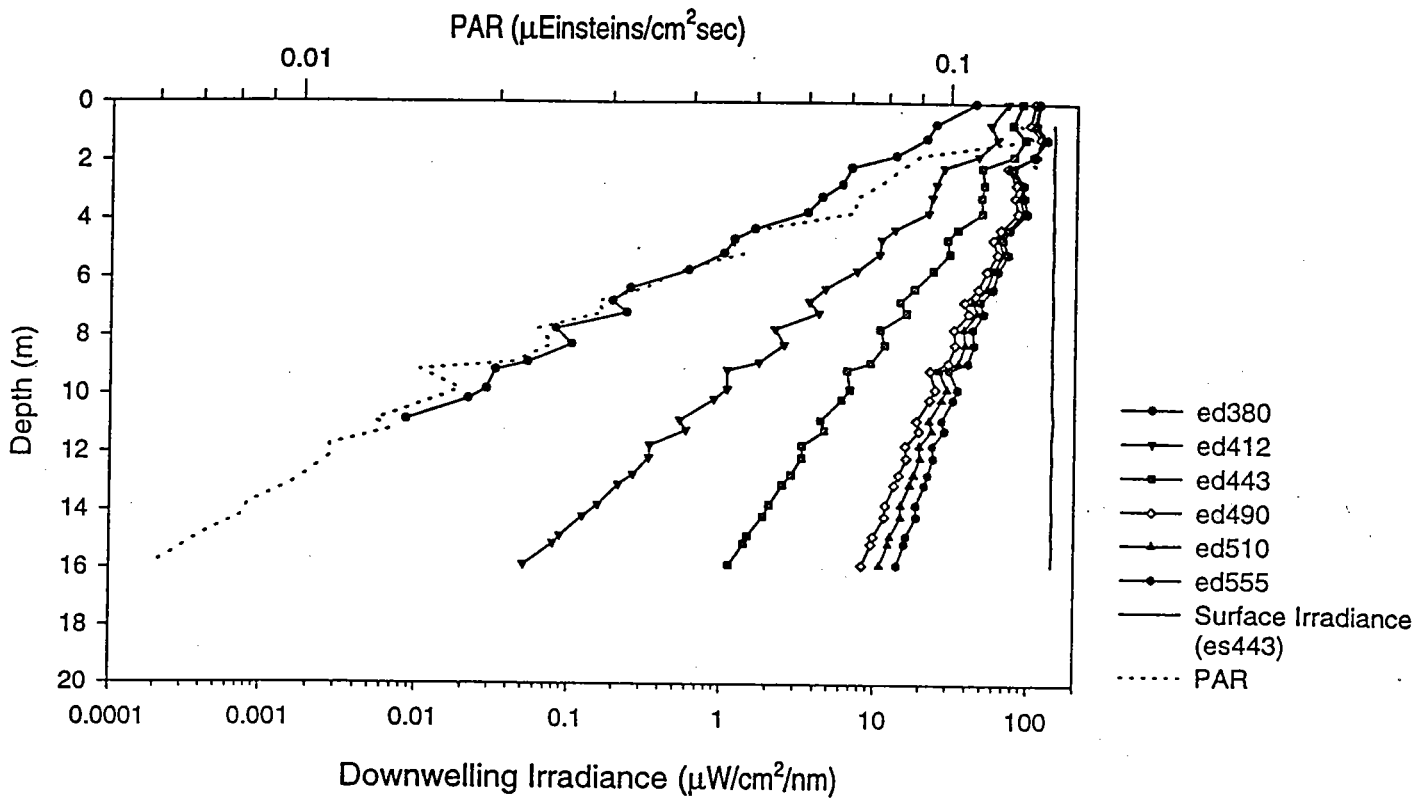
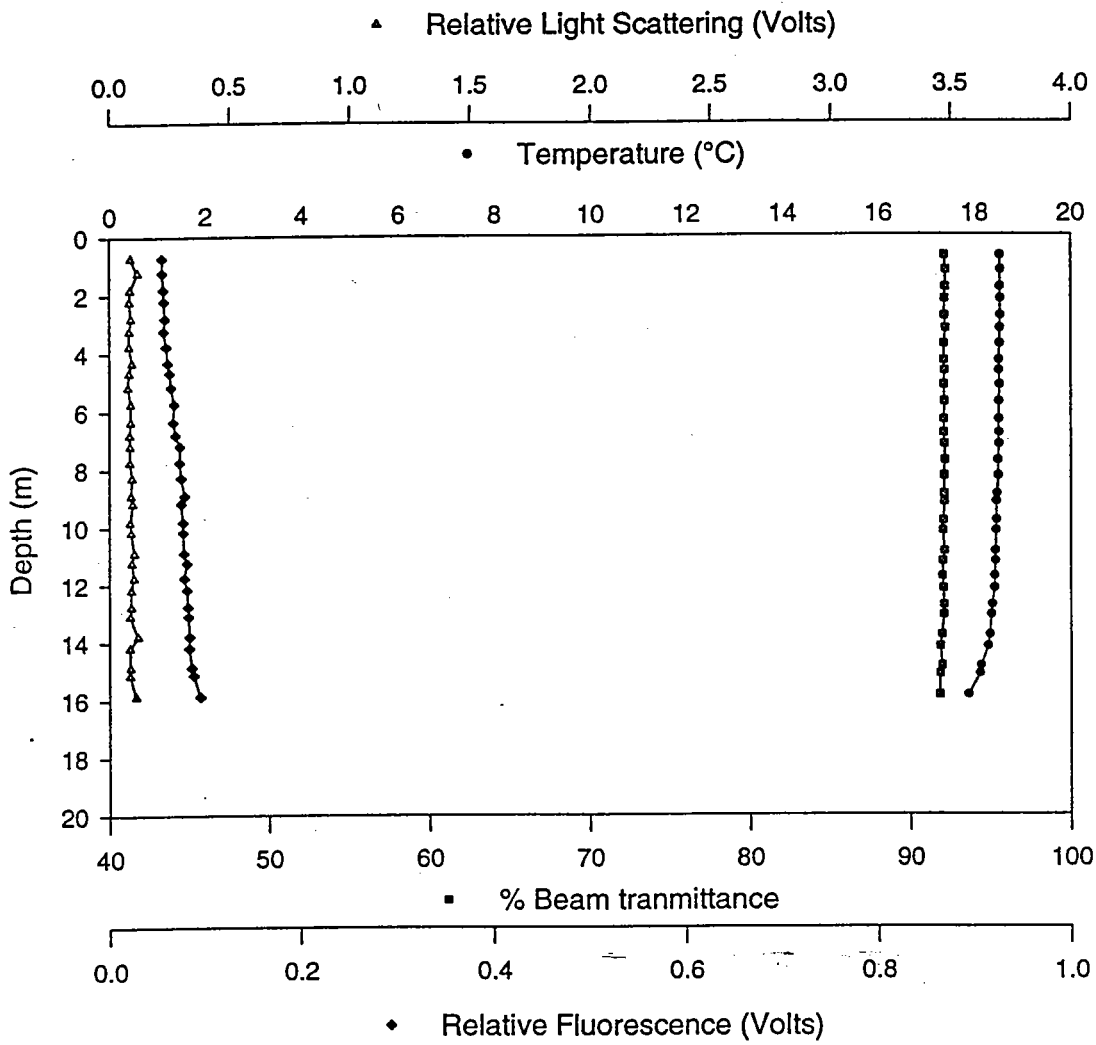

Figure A.24b - Station 3.2 Upcast



Diffuse Attenuation Coefficient (k_λ)

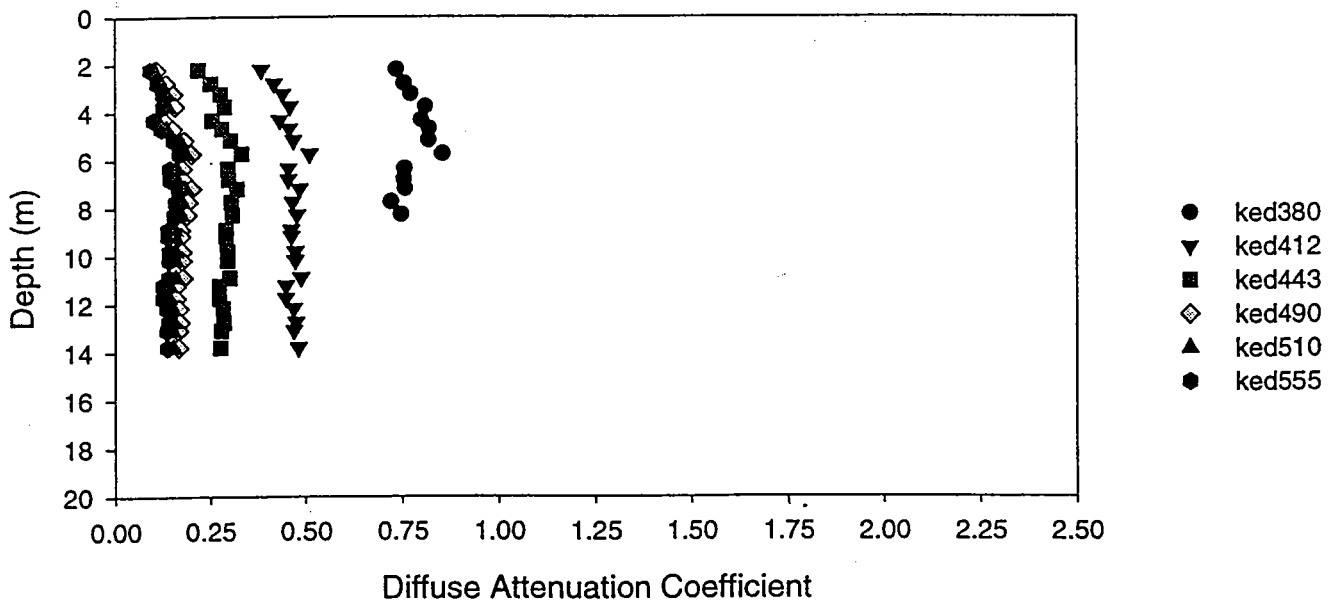

Figure A.25a - Station 3.3 Downcast

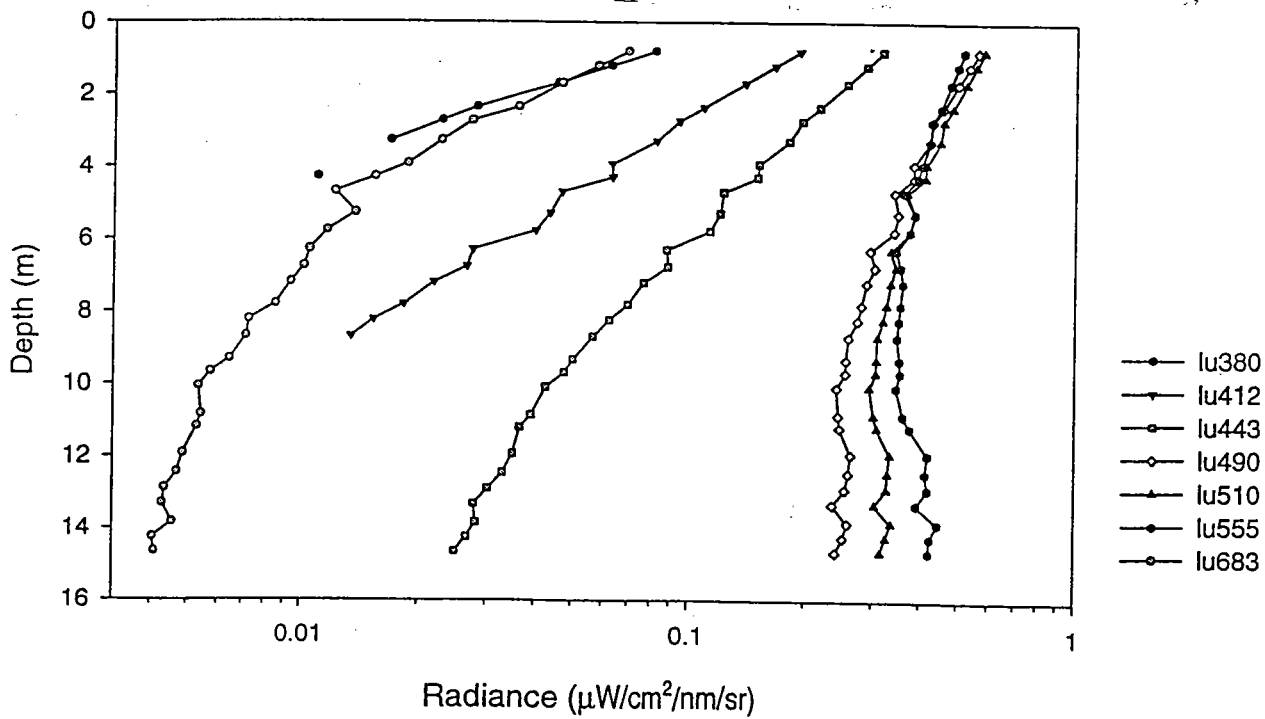
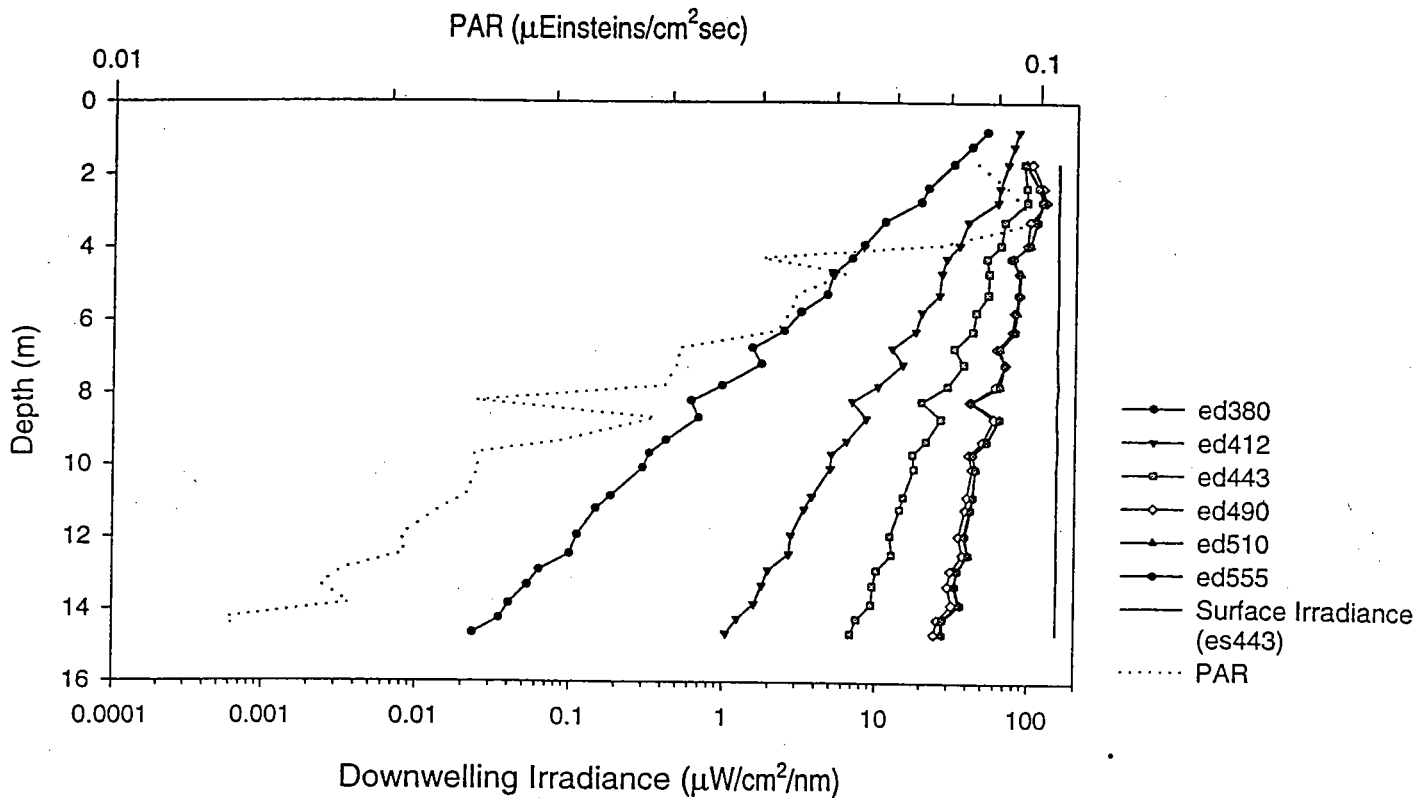
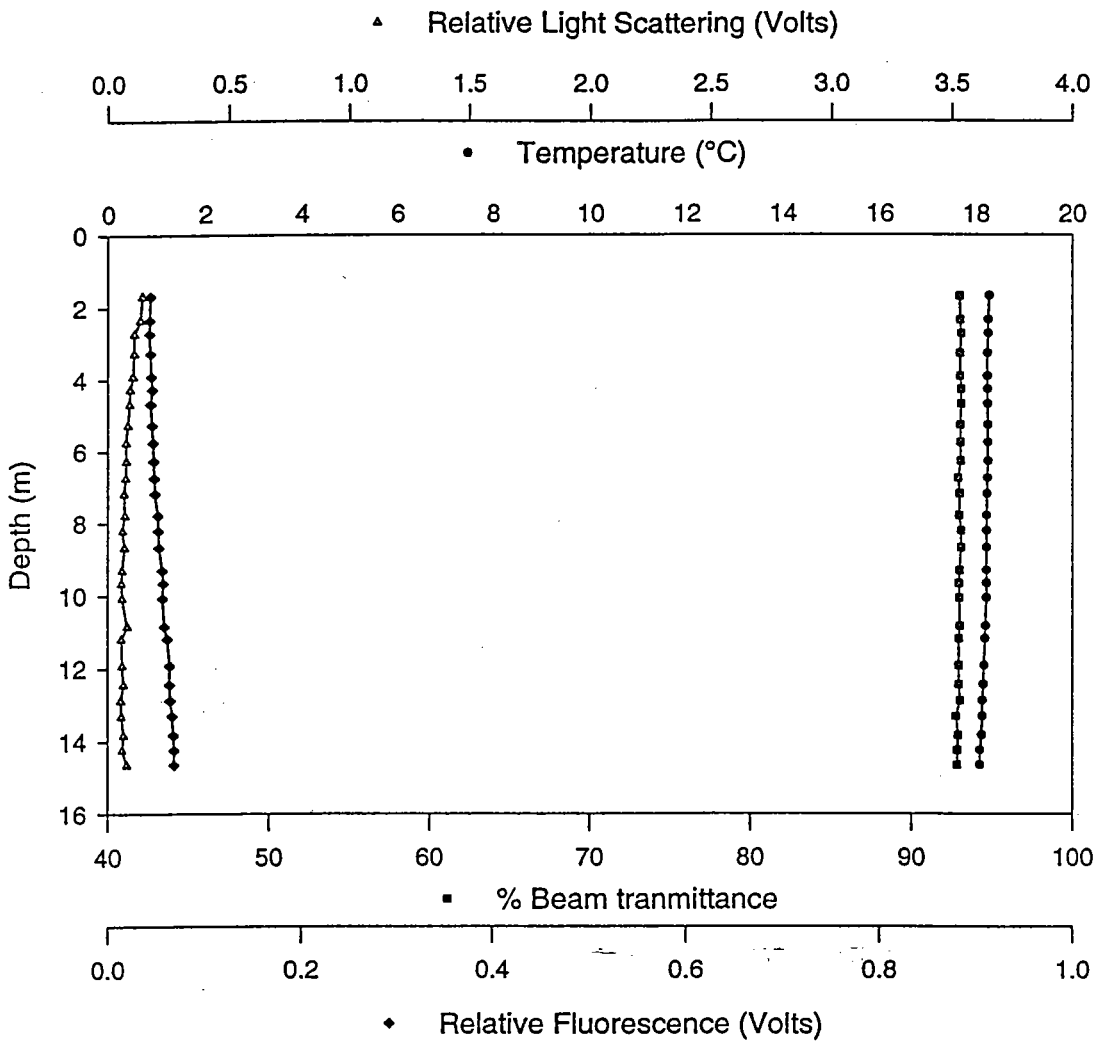

Figure A.25b - Station 3.3 Downcast



Diffuse Attenuation Coefficient (k_{λ})

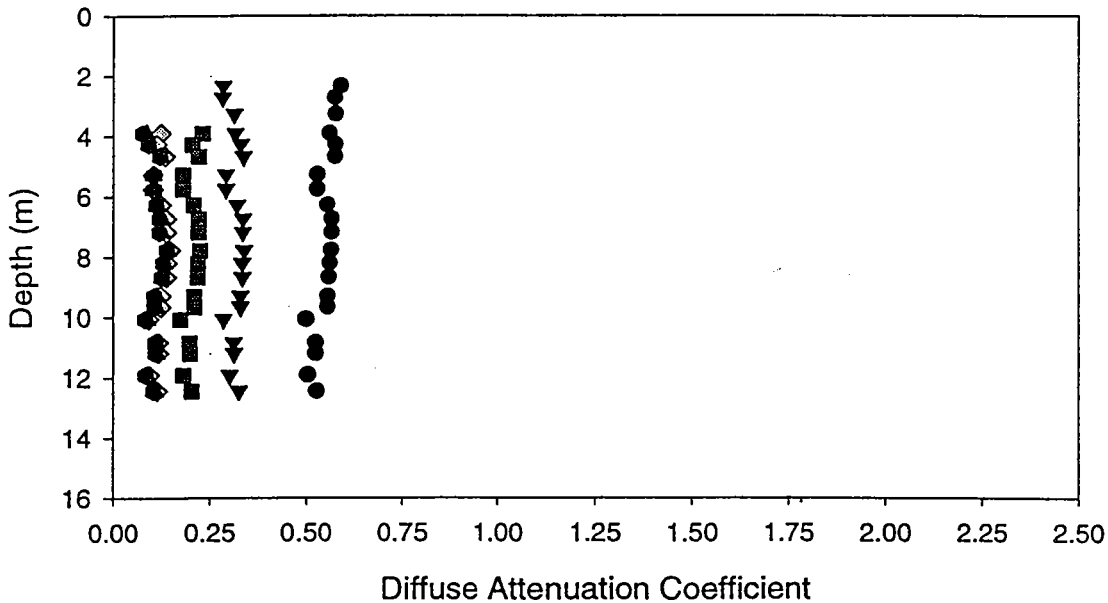

Figure A.26a - Station 3.3 Upcast

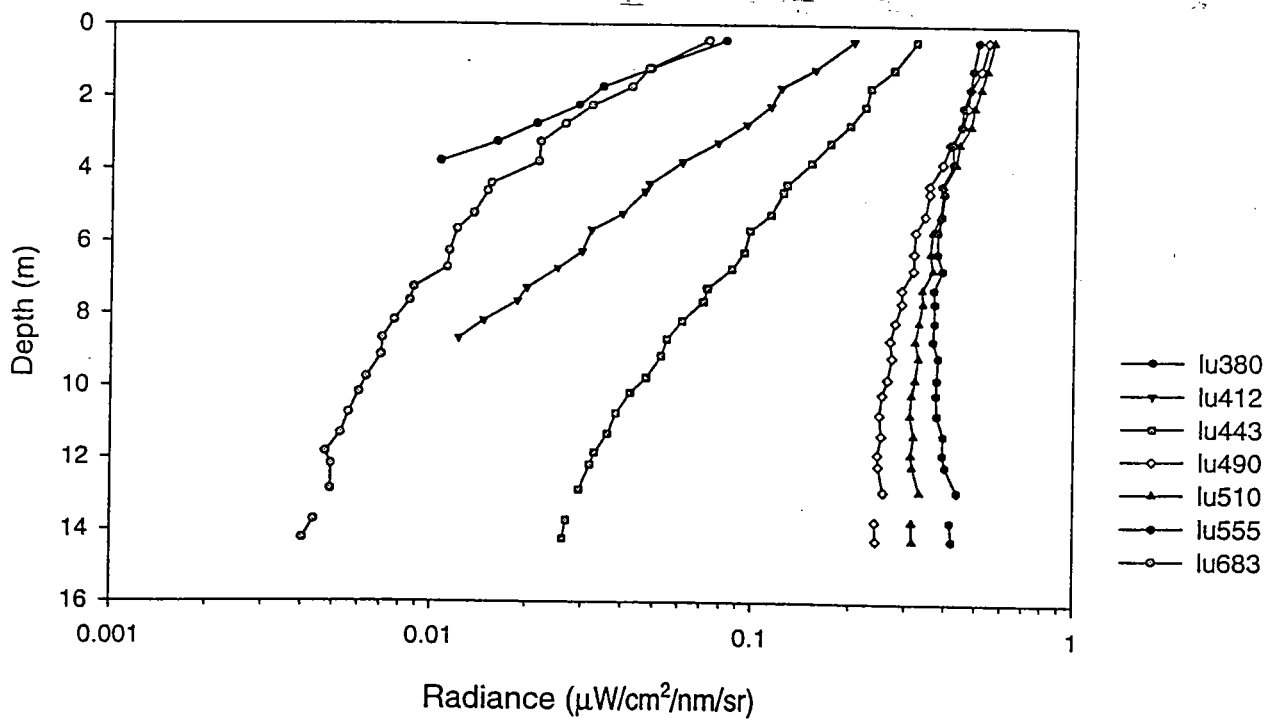
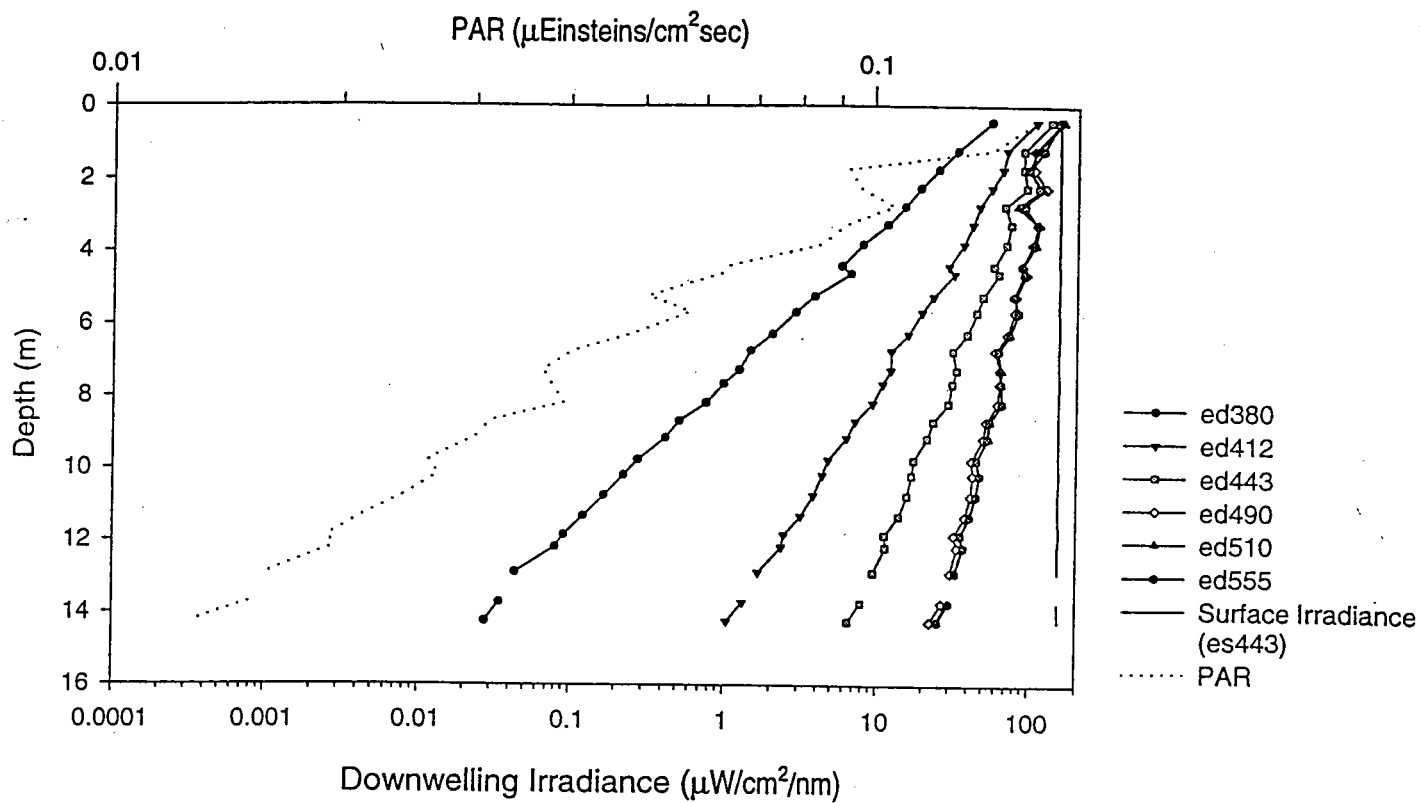
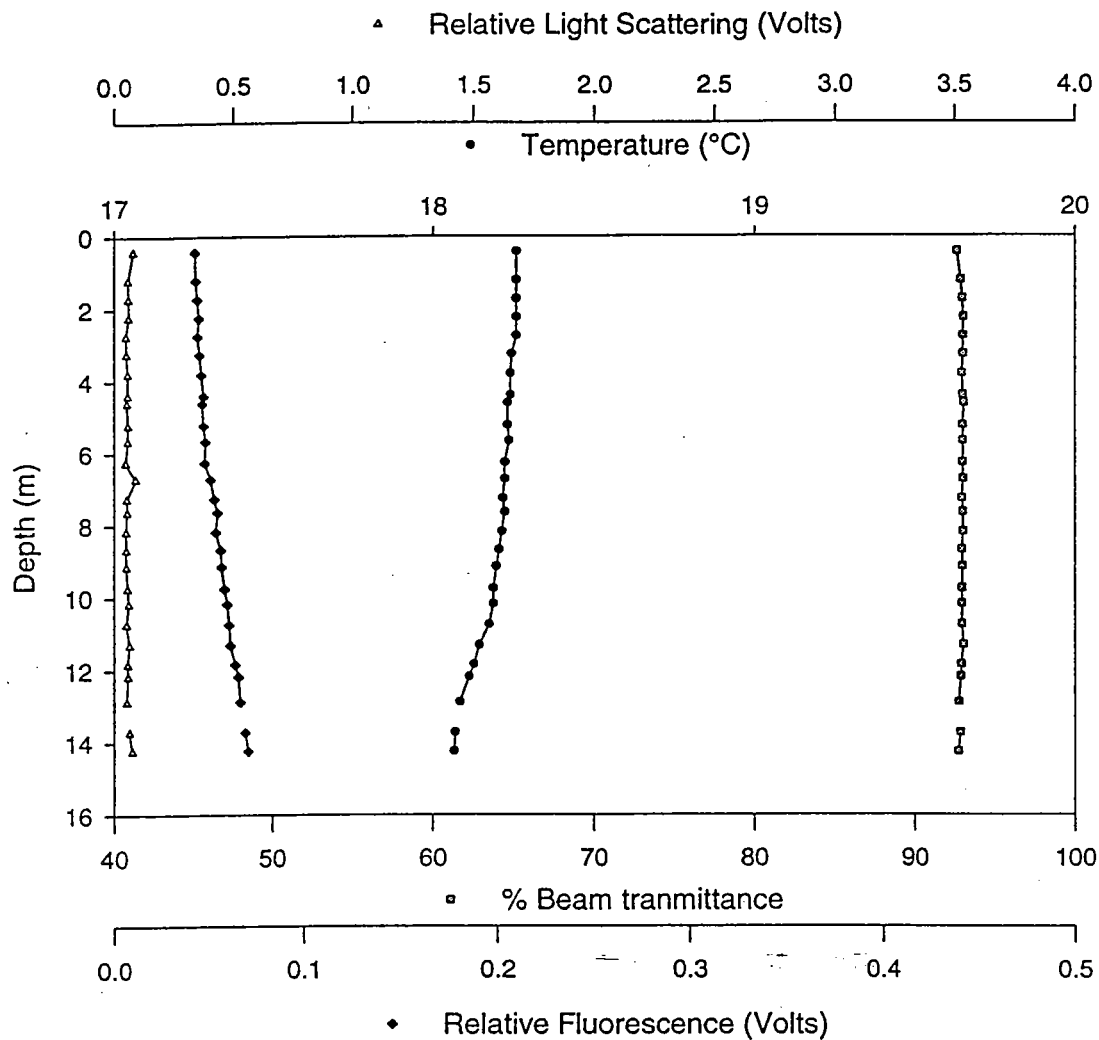

Figure A.26b - Station 3.3 Upcast



Diffuse Attenuation Coefficient ($k\lambda$)

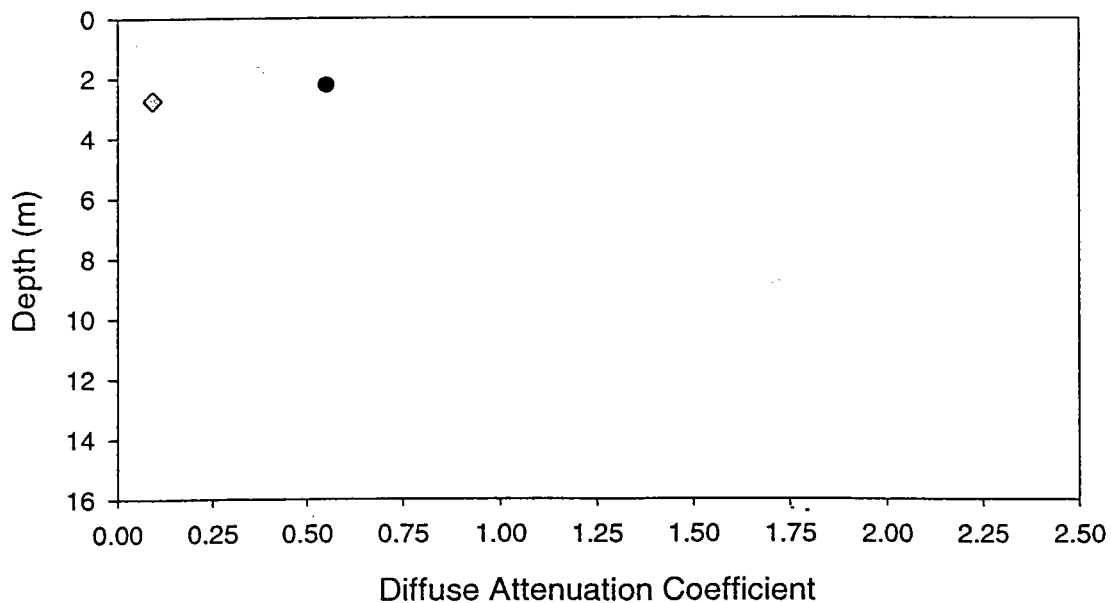

Figure A.27a - Station 4.1 Downcast

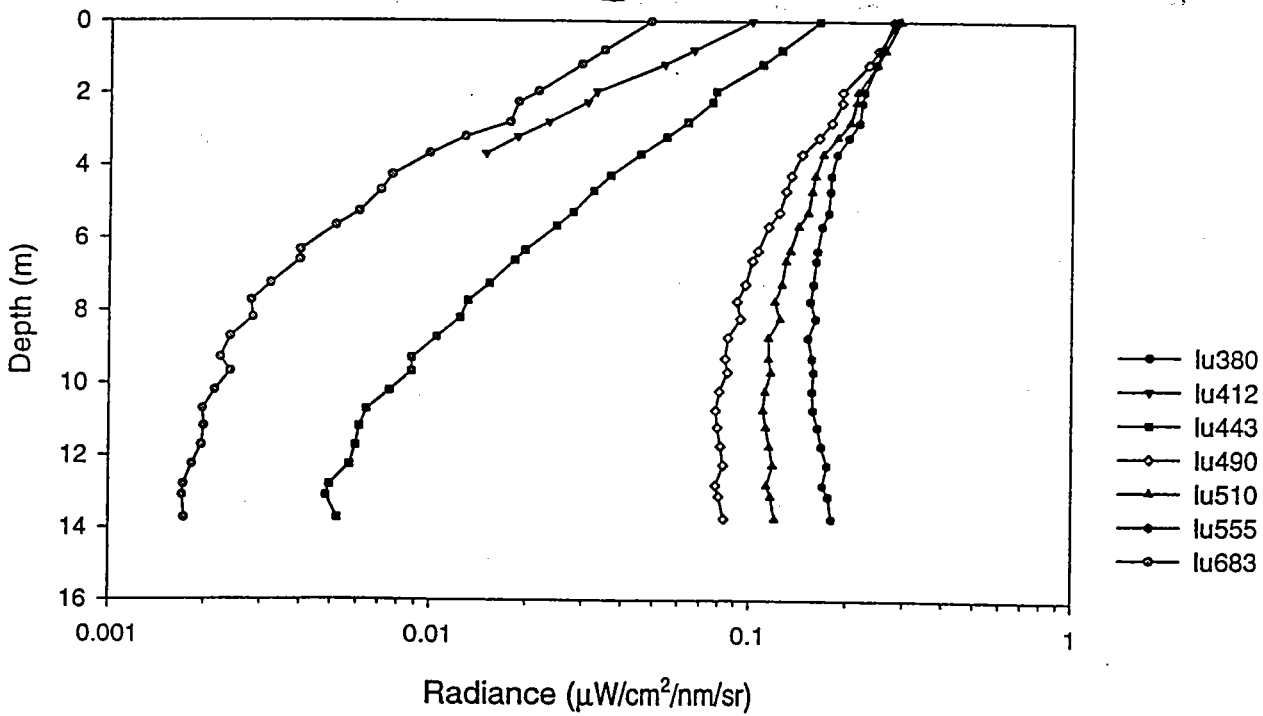
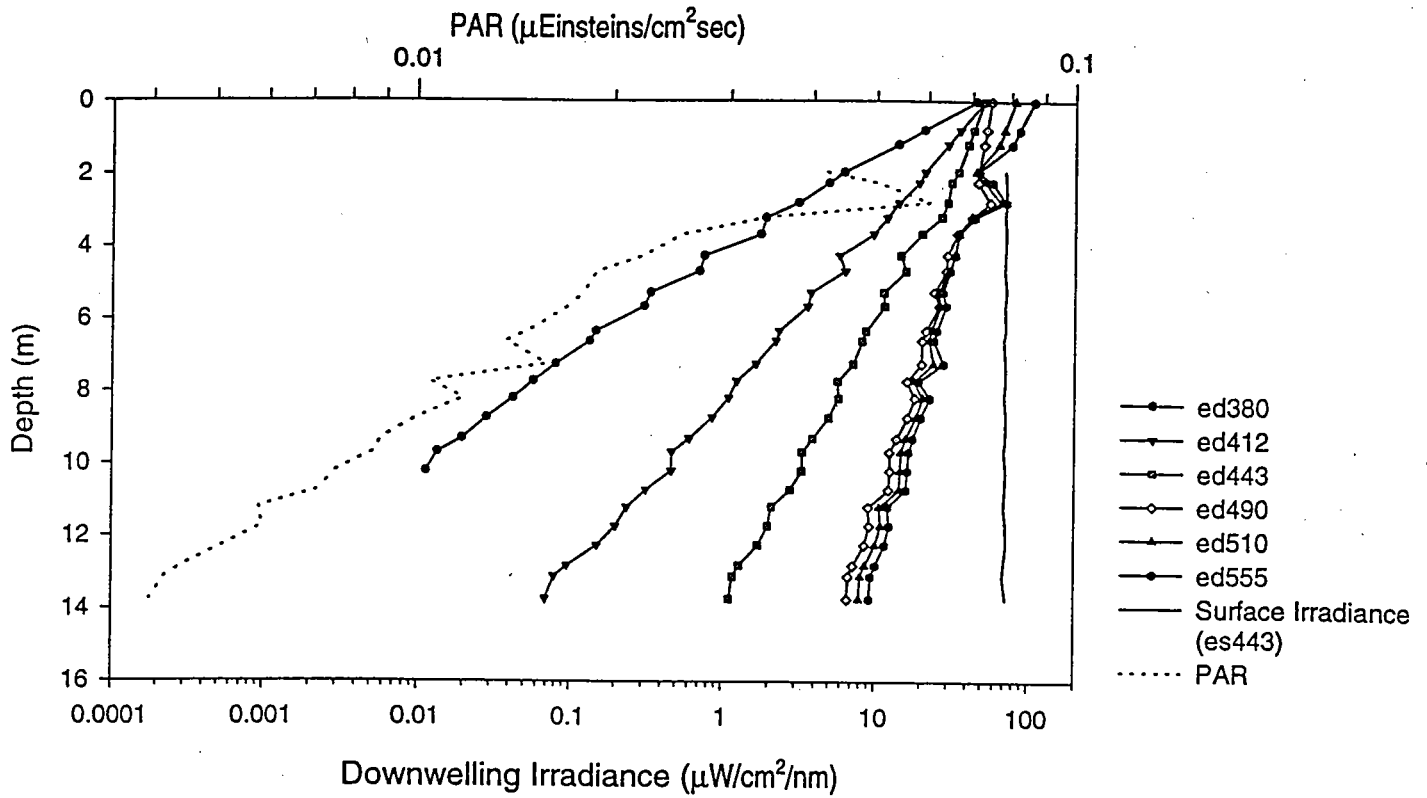
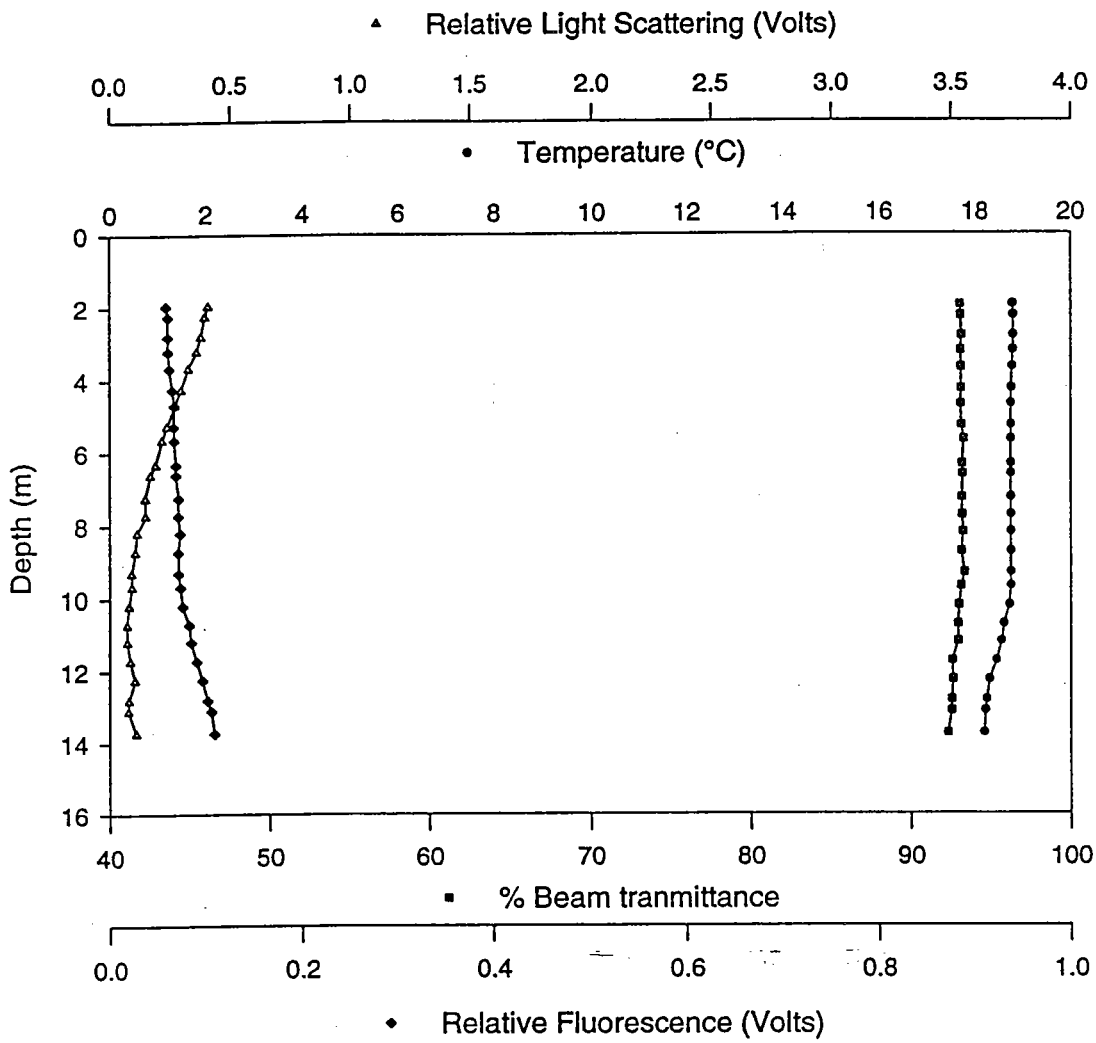

Figure A.27b - Station 4.1 Downcast



Diffuse Attenuation Coefficient (k_λ)

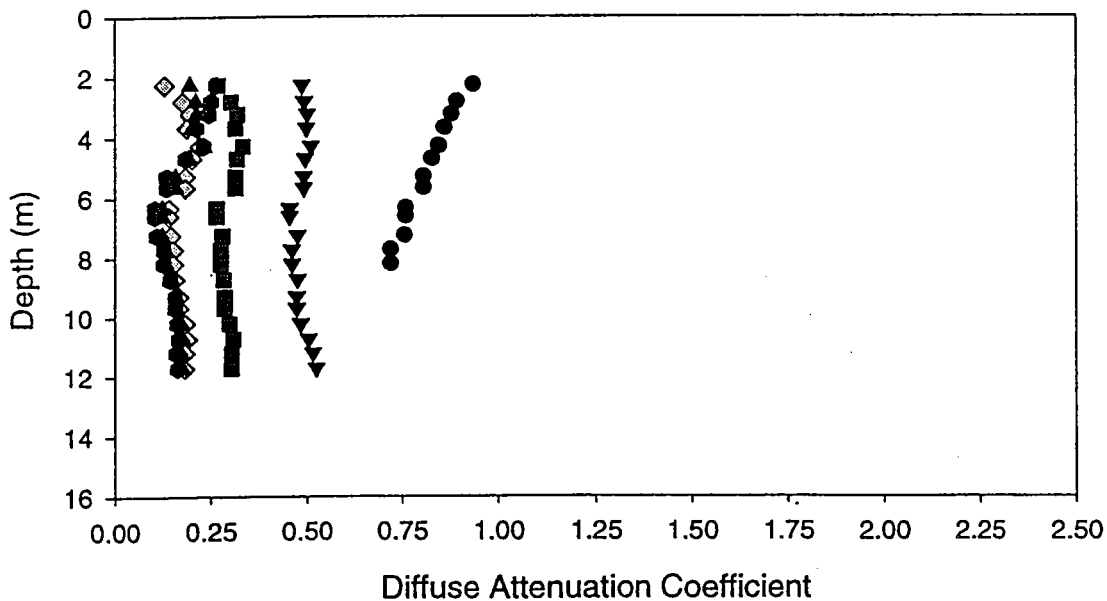

Figure A.28a - Station 4.1 Upcast

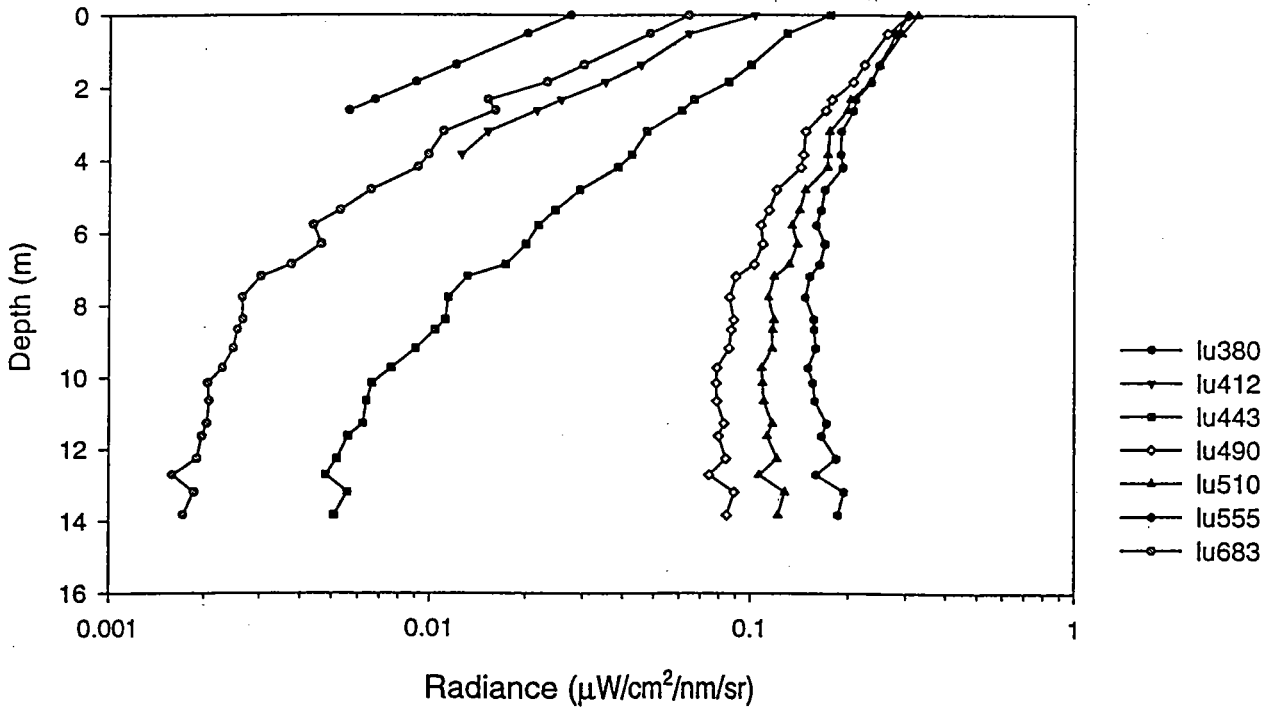
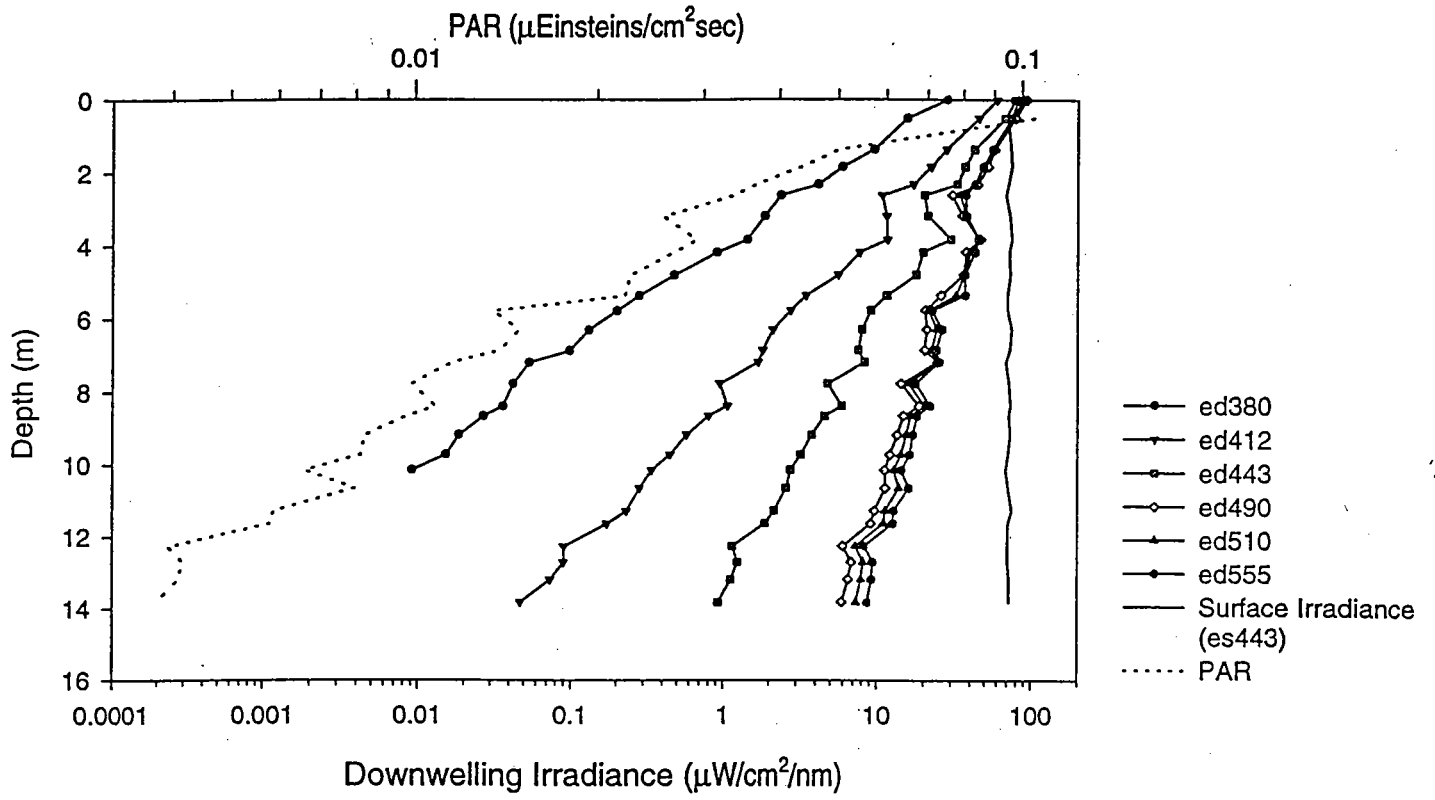
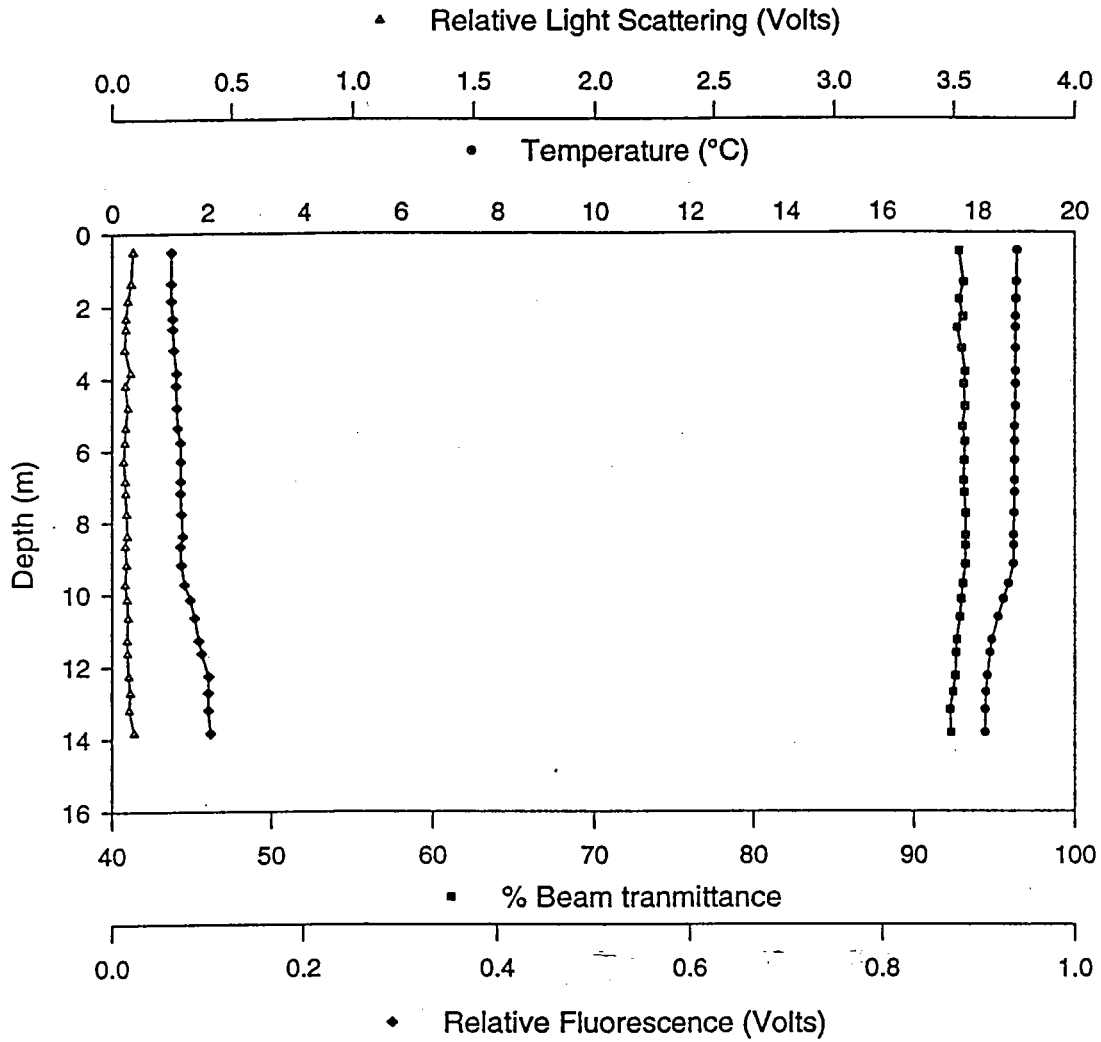

Figure A.28b - Station 4.1 Upcast



Diffuse Attenuation Coefficient (k_λ)

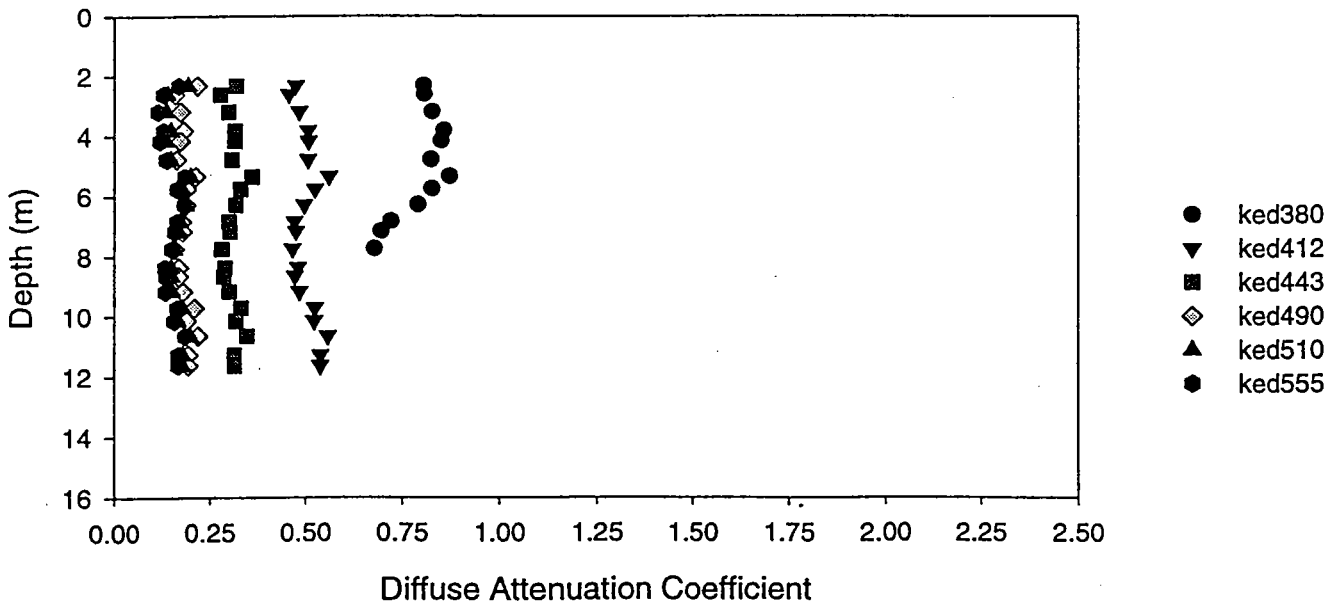

Figure A.29a - Station 4.2 Downcast

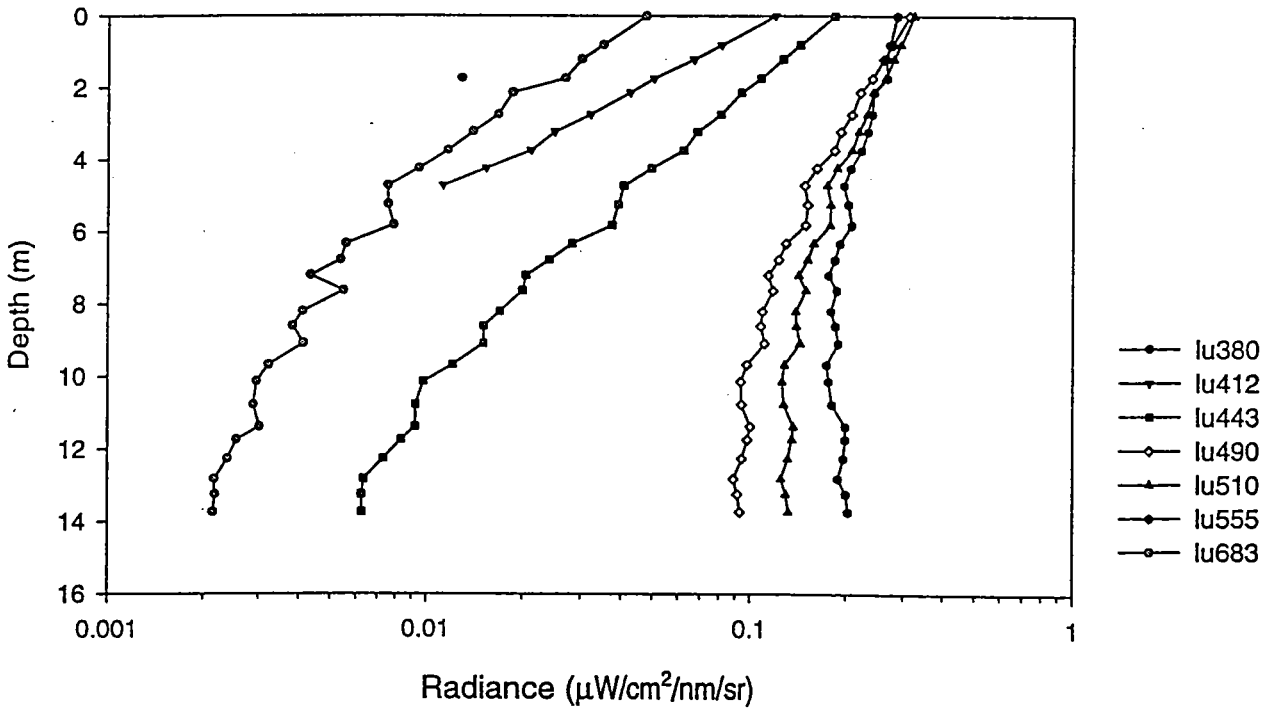
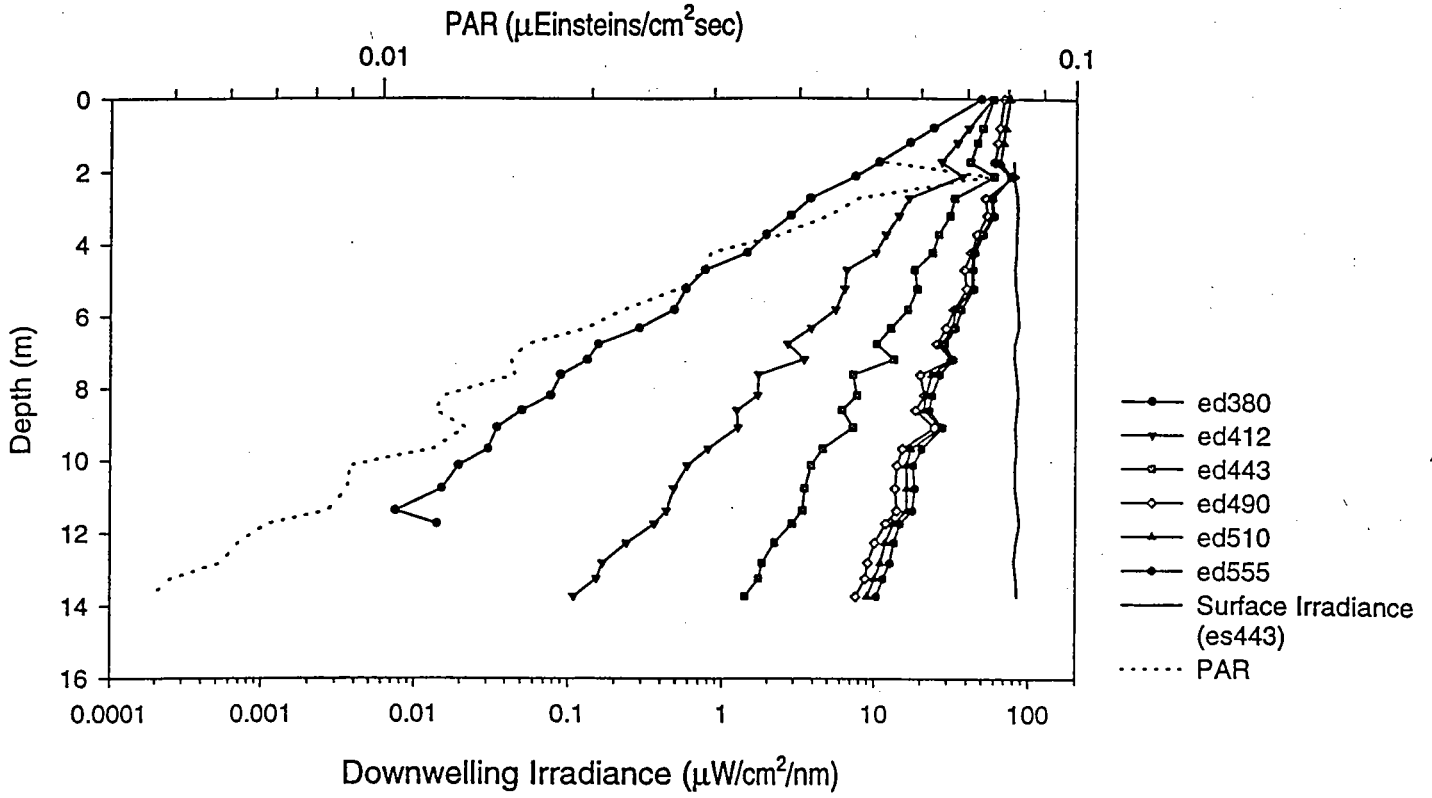
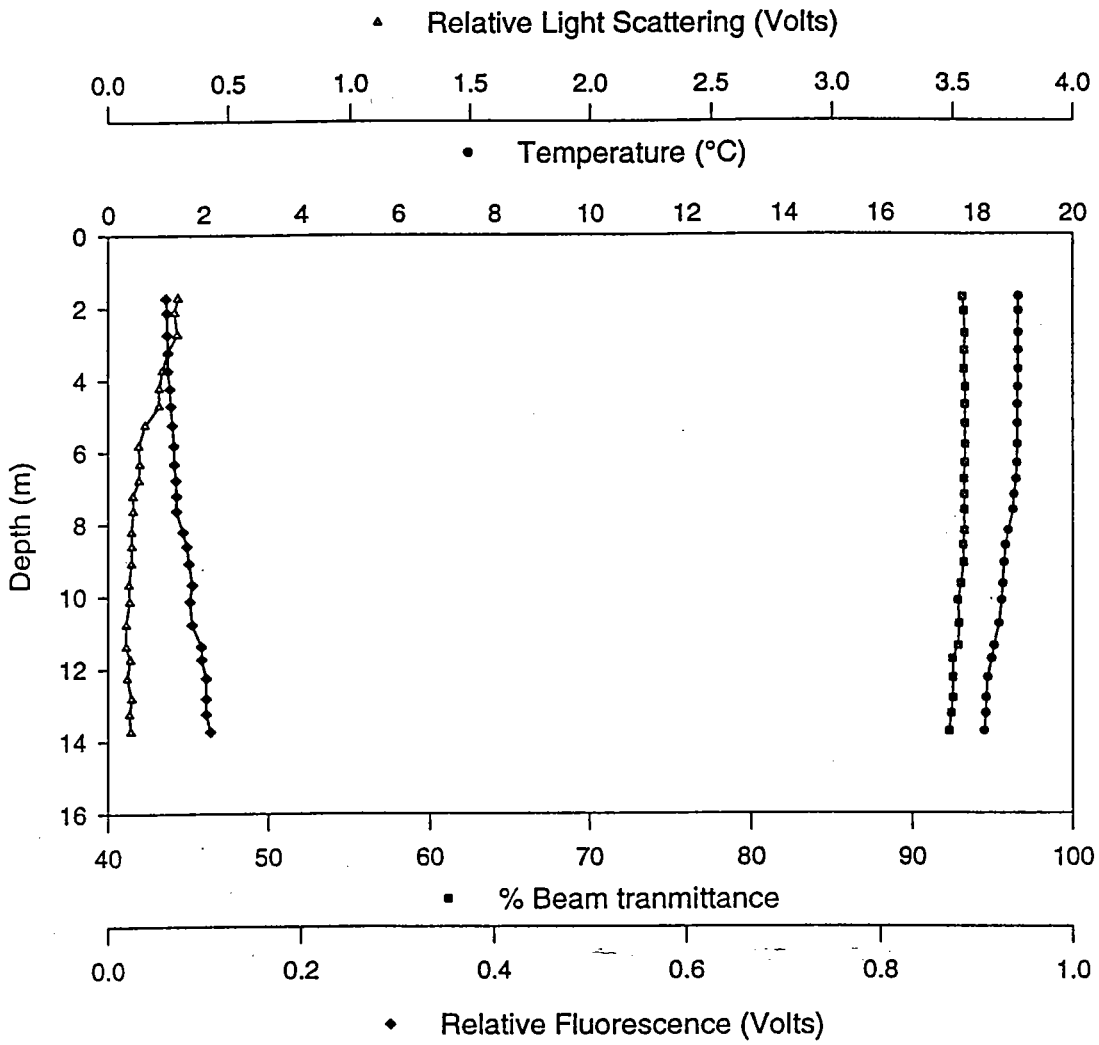

Figure A.29b - Station 4.2 Downcast



Diffuse Attenuation Coefficient ($k\lambda$)

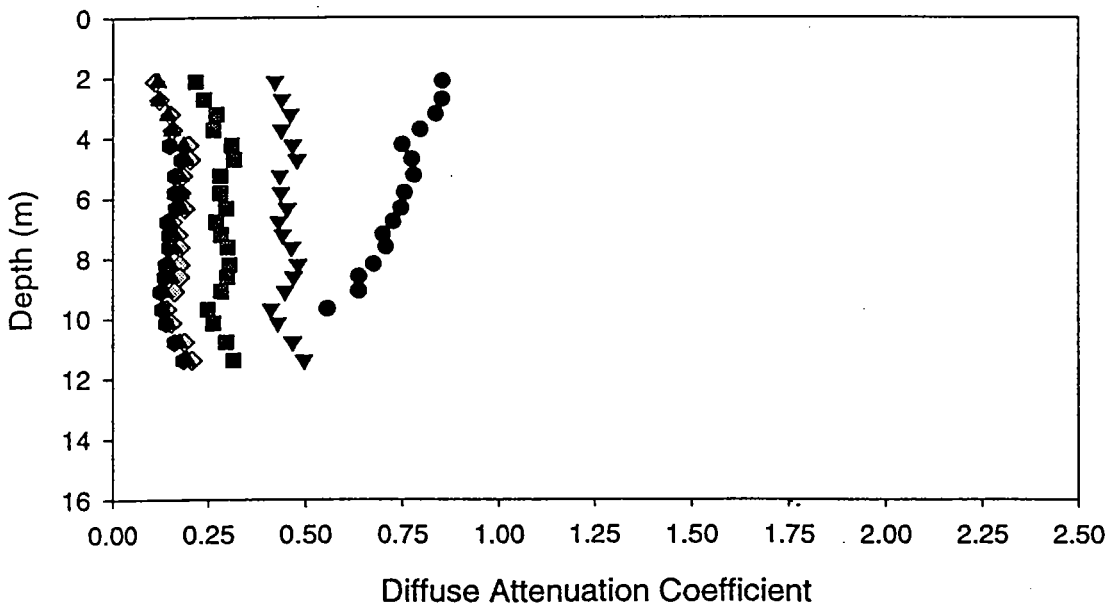

Figure A.30a - Station 4.2 Upcast

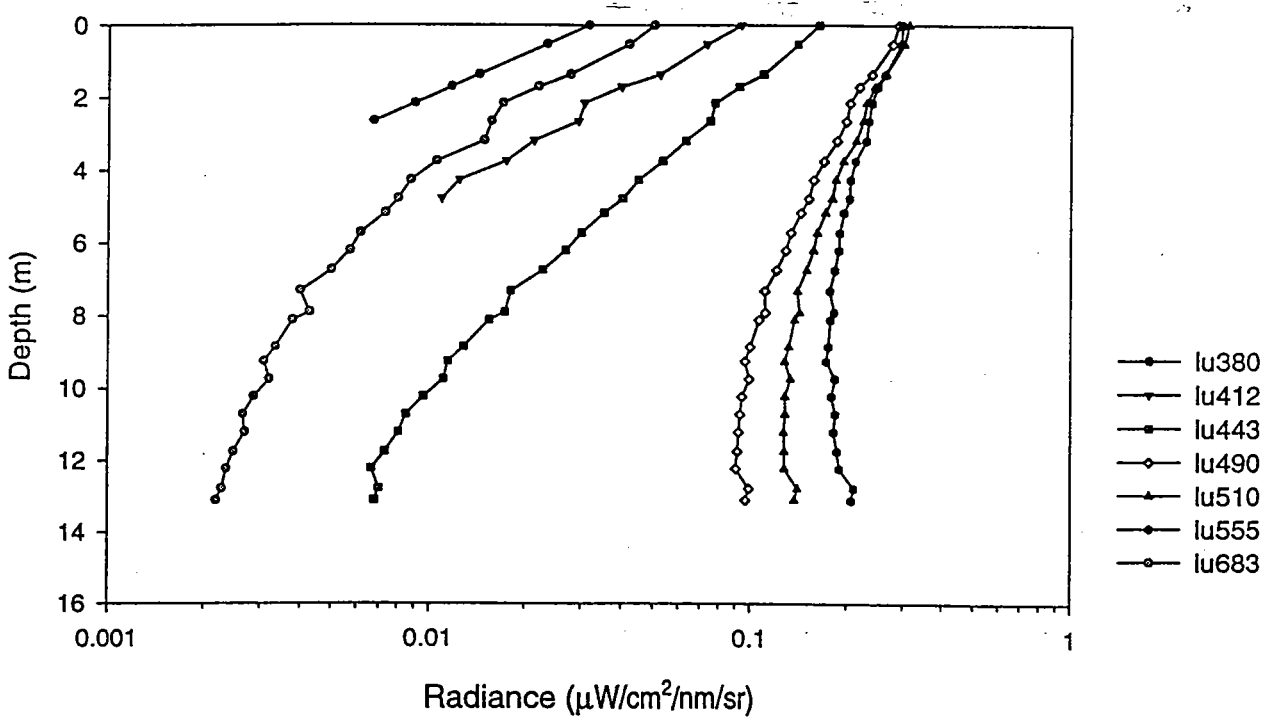
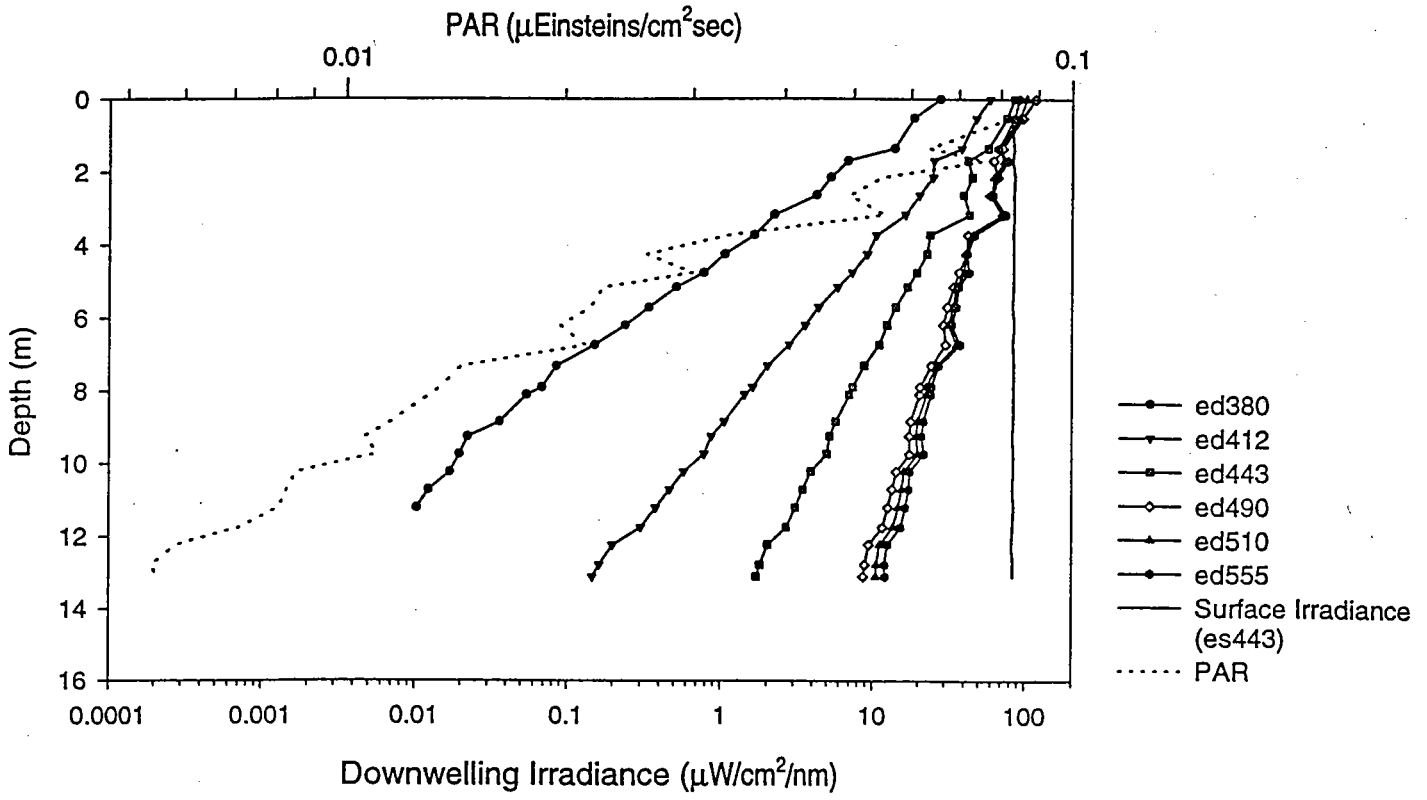
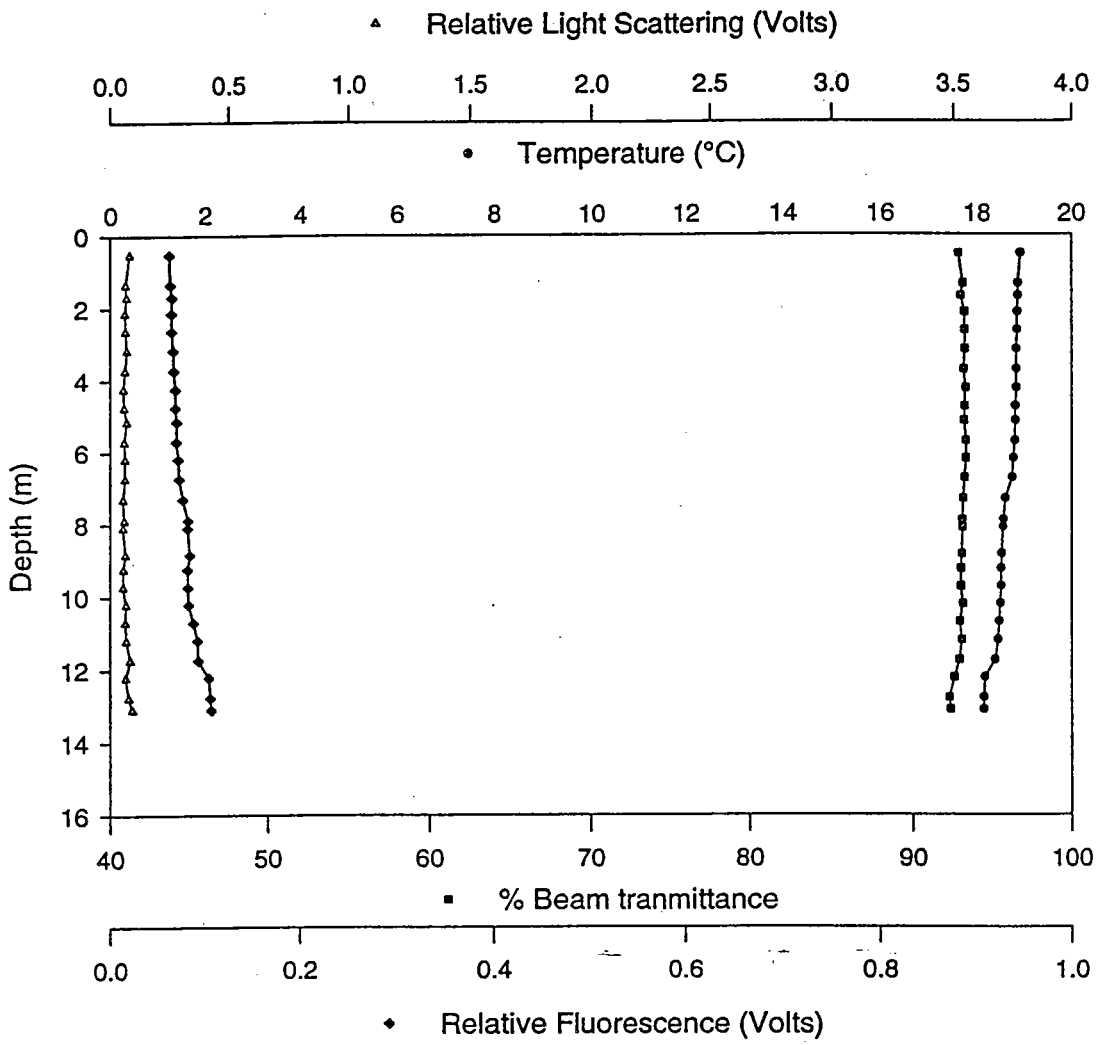

Figure A.30b - Station 4.2 Upcast



Diffuse Attenuation Coefficient ($k\lambda$)

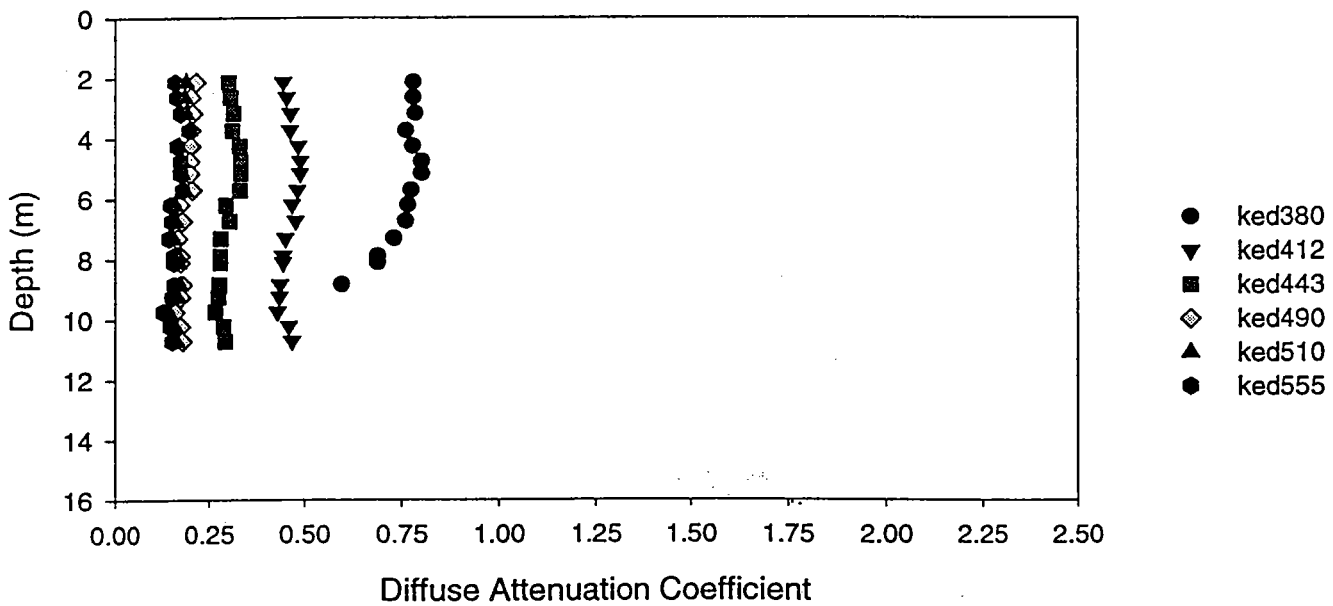

Figure A.31a - Station 4.3 Downcast (W27)

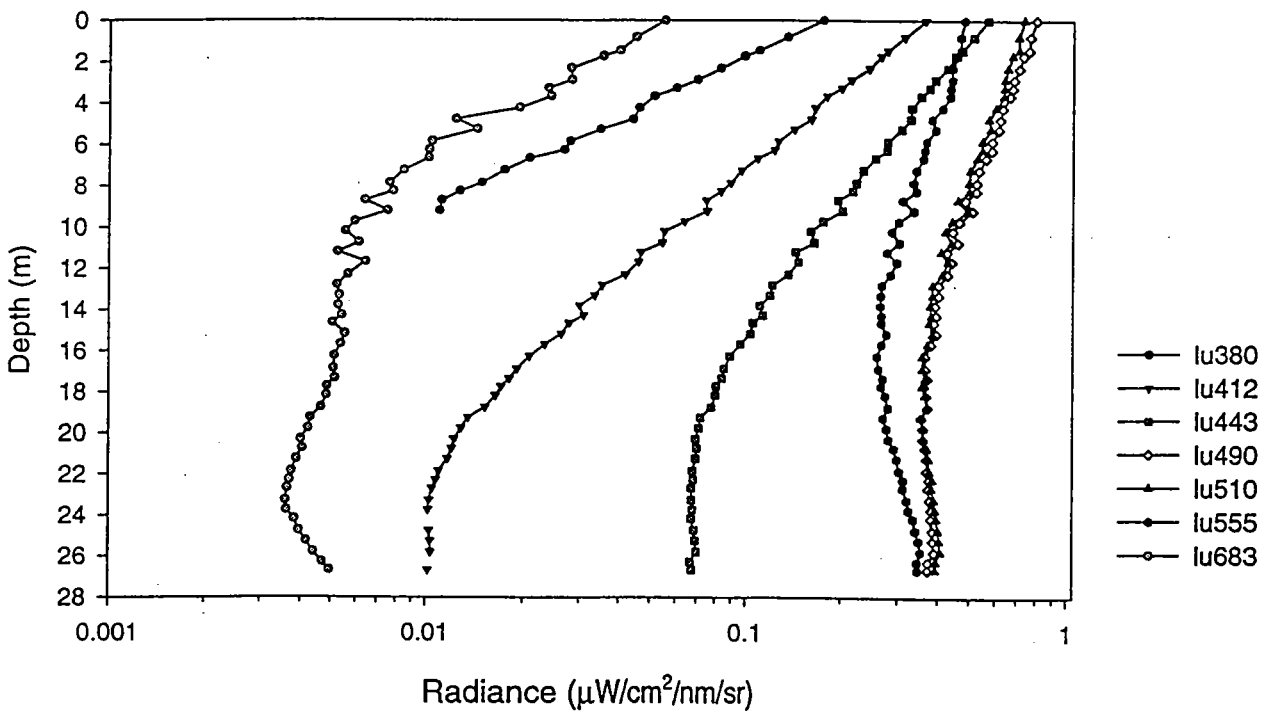
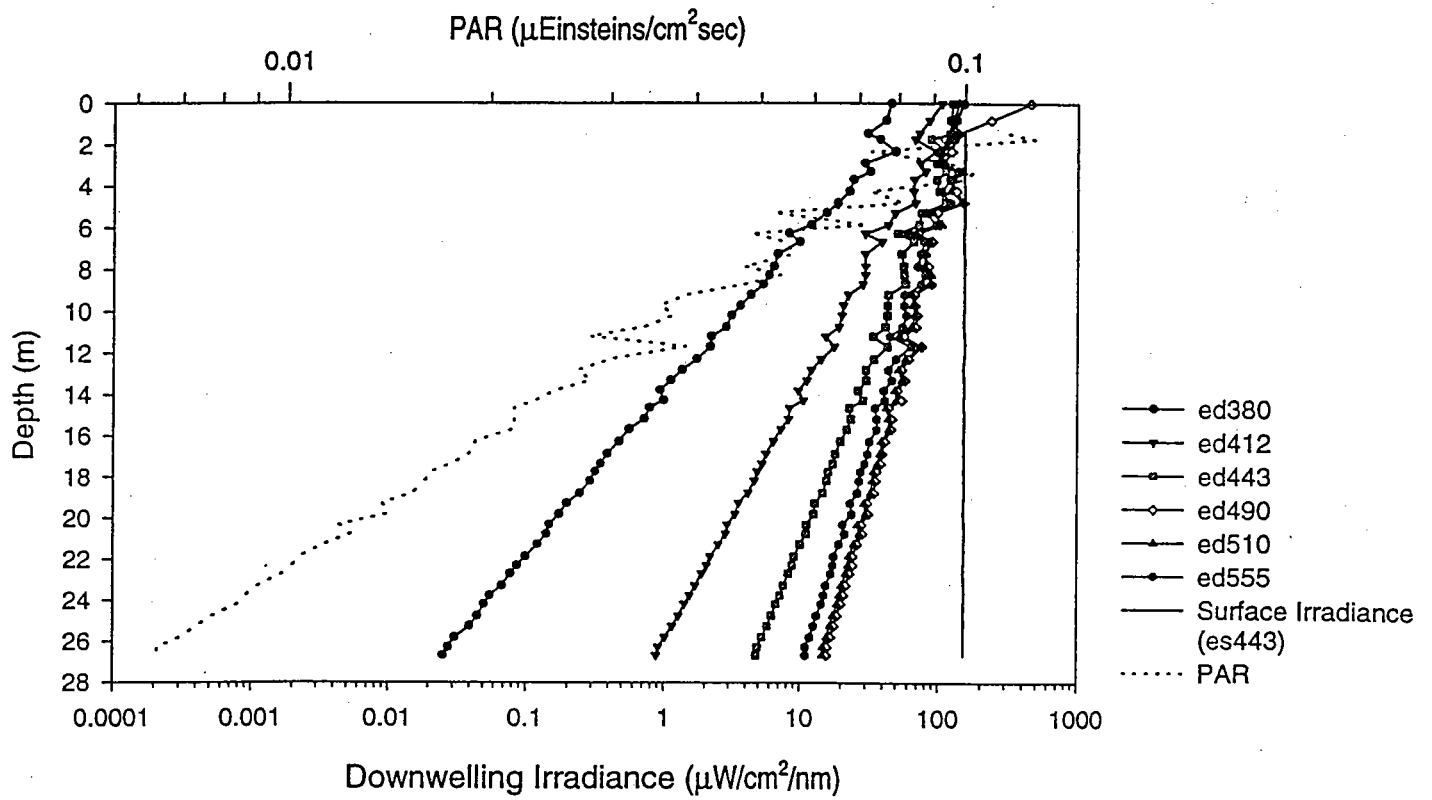
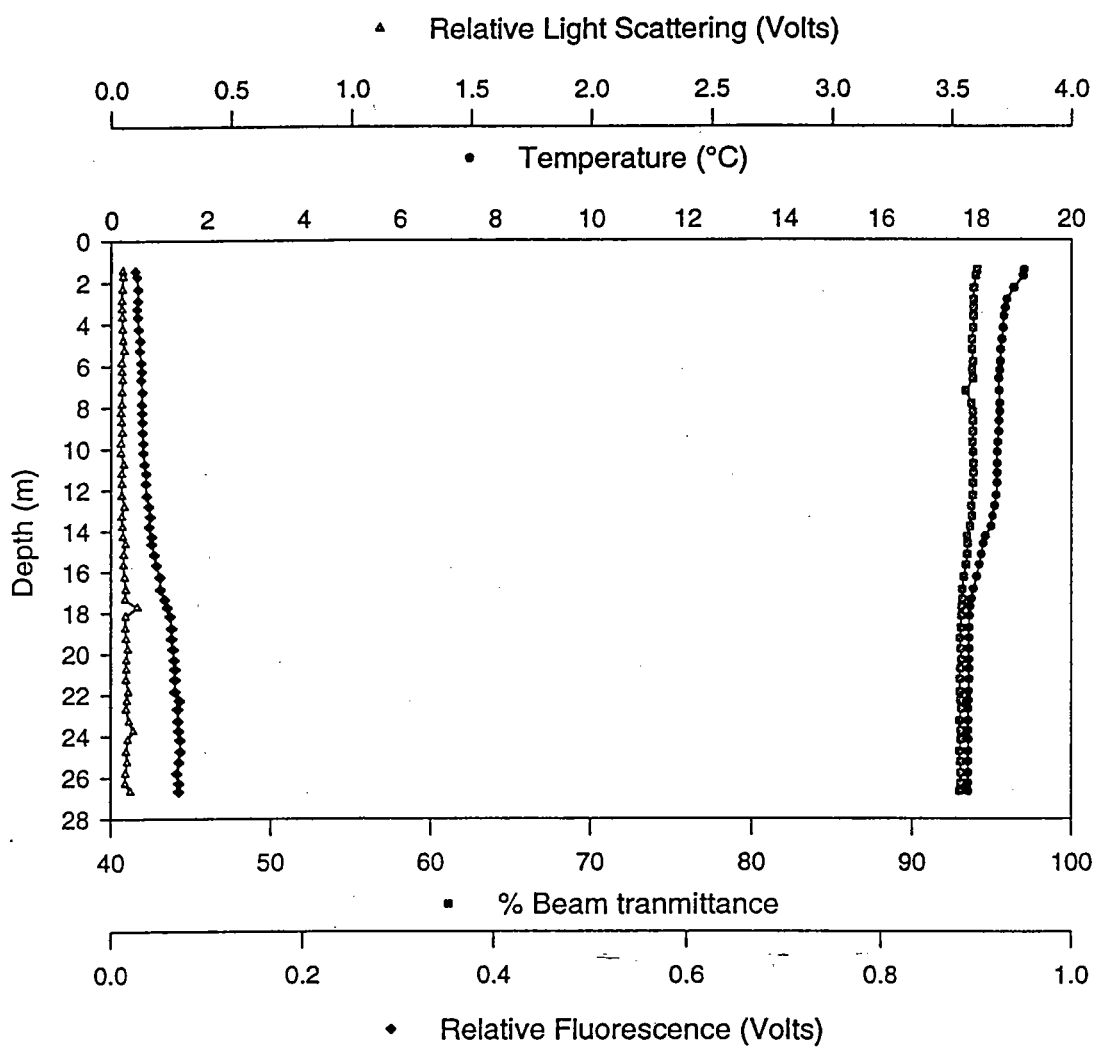

Figure A.31b - Station 4.3 Downcast



Diffuse Attenuation Coefficient ($k\lambda$)

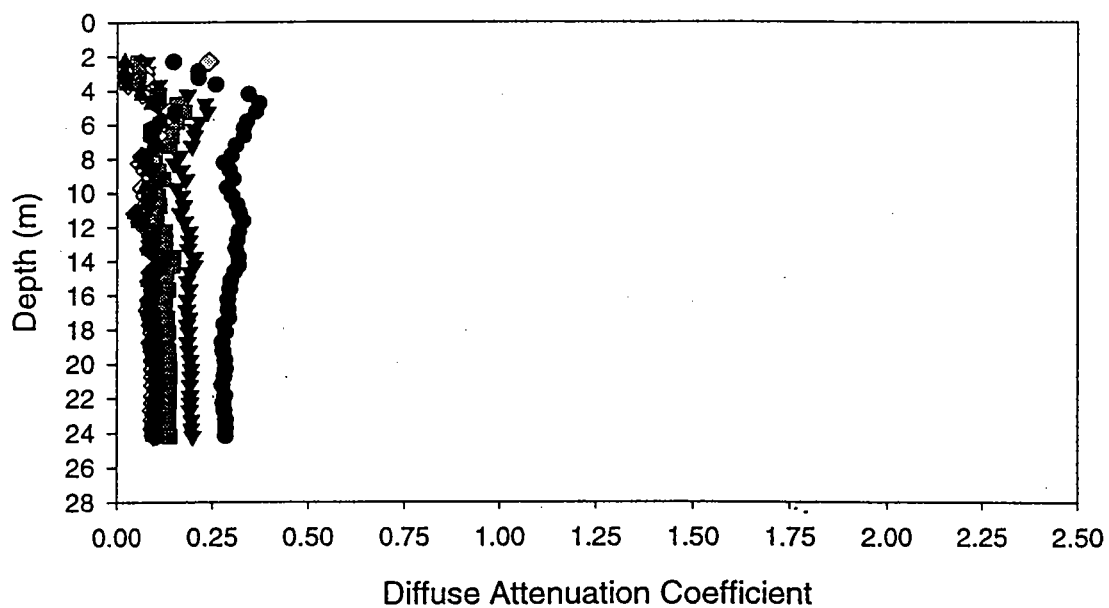

Figure A.32a - Station 4.3 Upcast

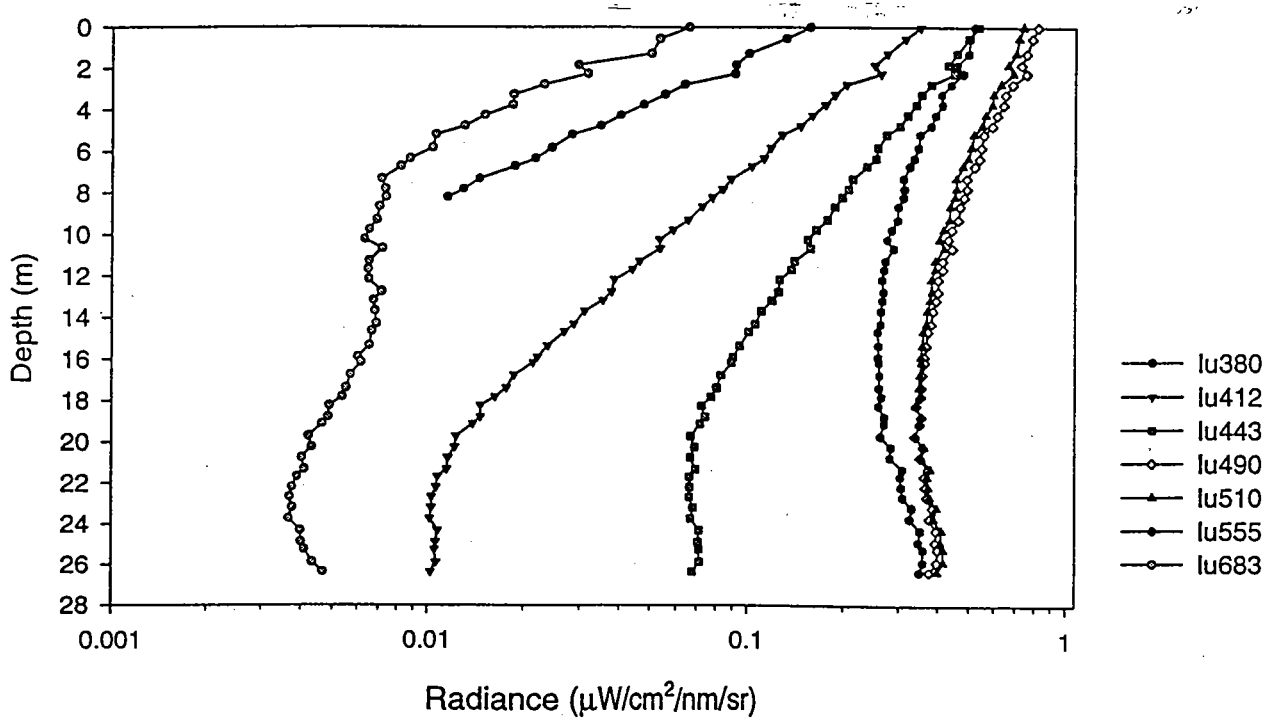
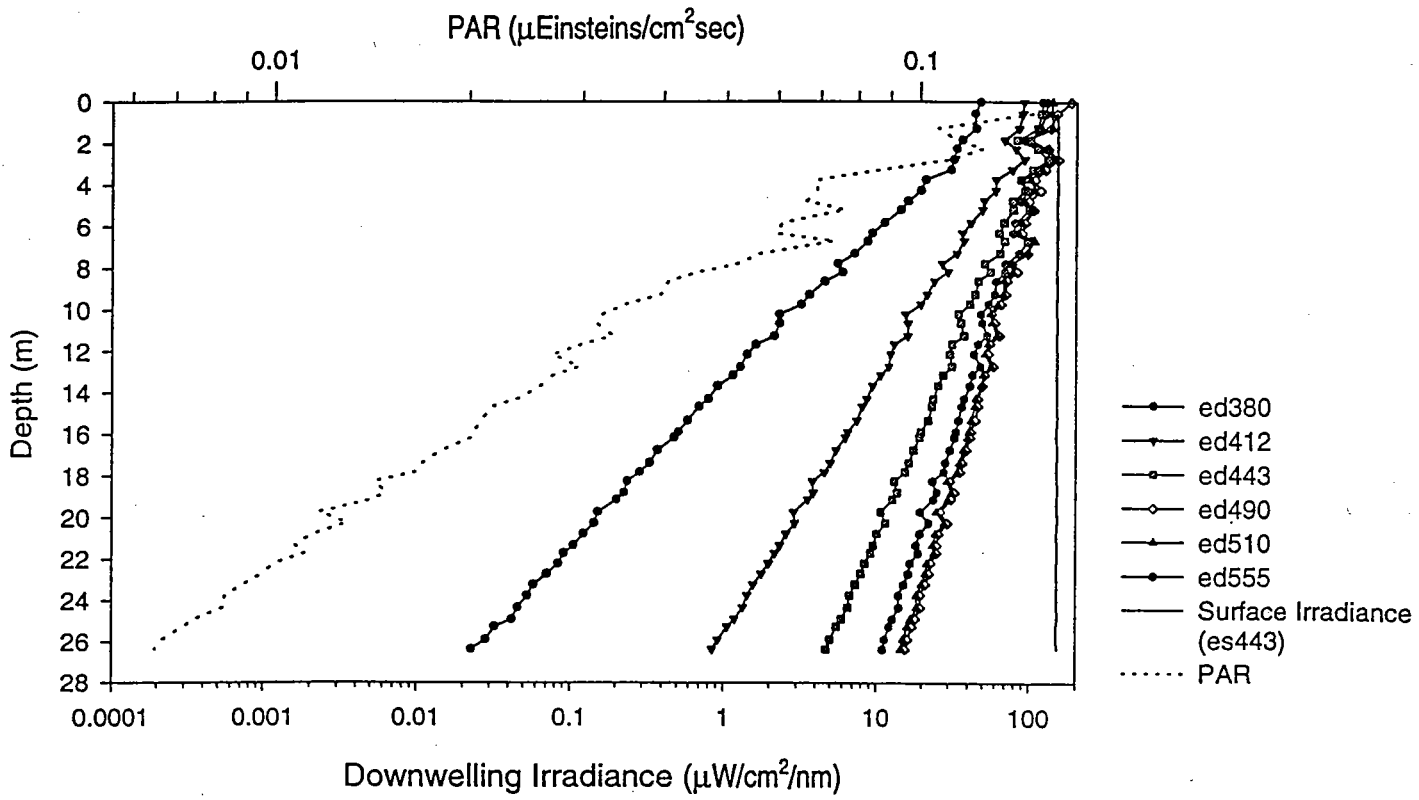
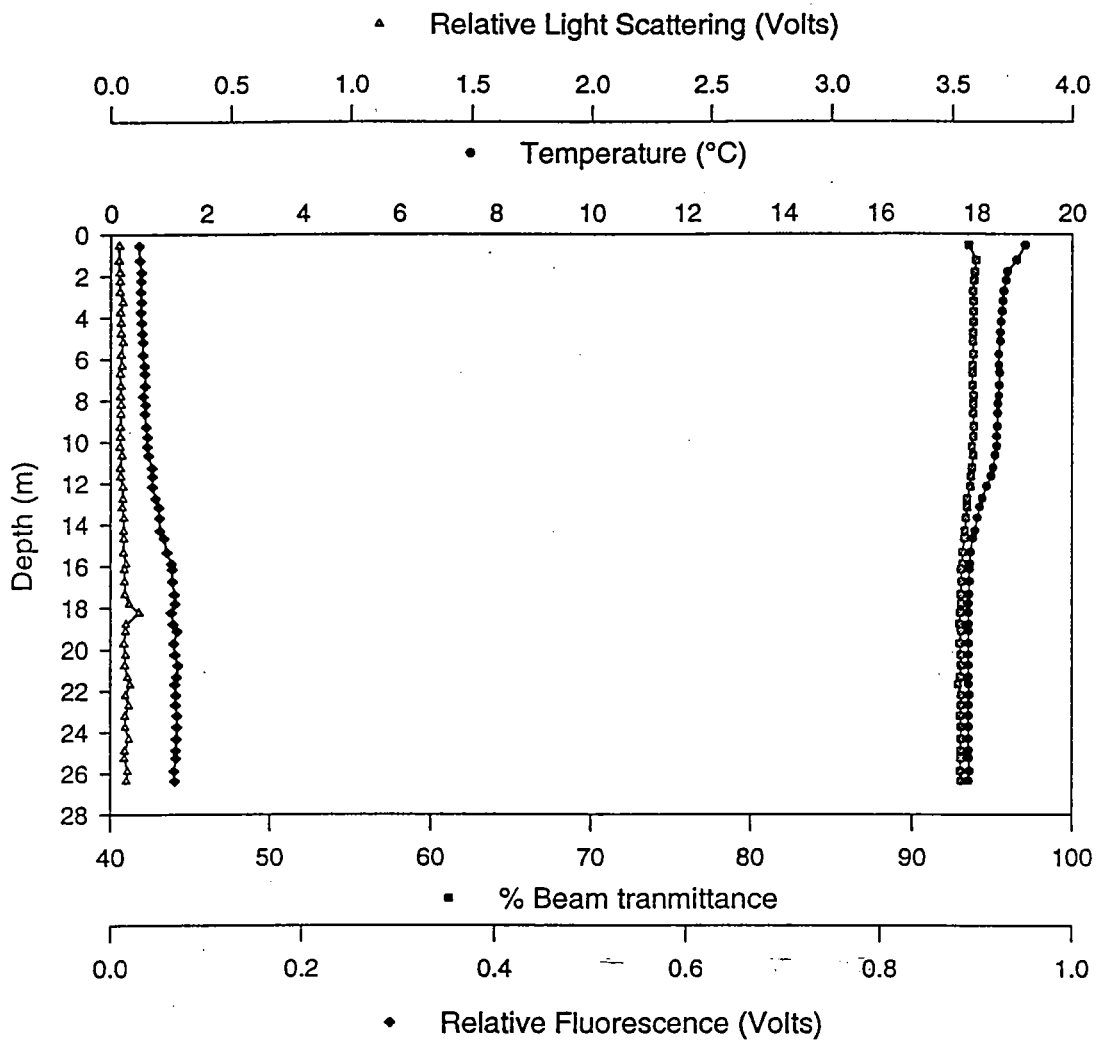

Figure A.32b - Station 4.3 Upcast



Diffuse Attenuation Coefficient ($k\lambda$)

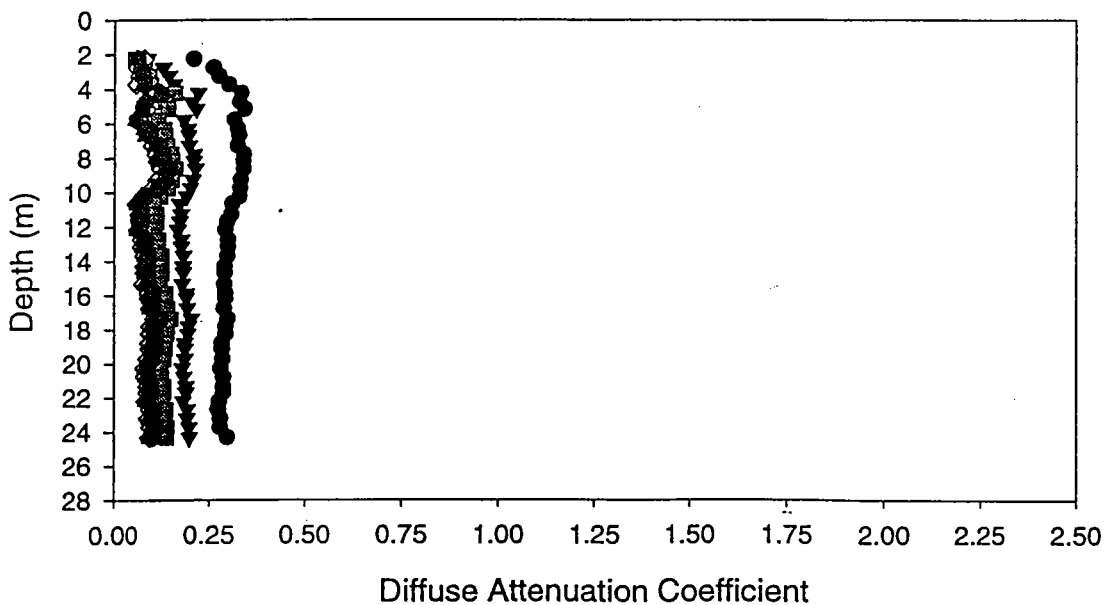

Figure A. 33 Station 3.3 CTD
April 24, 1996

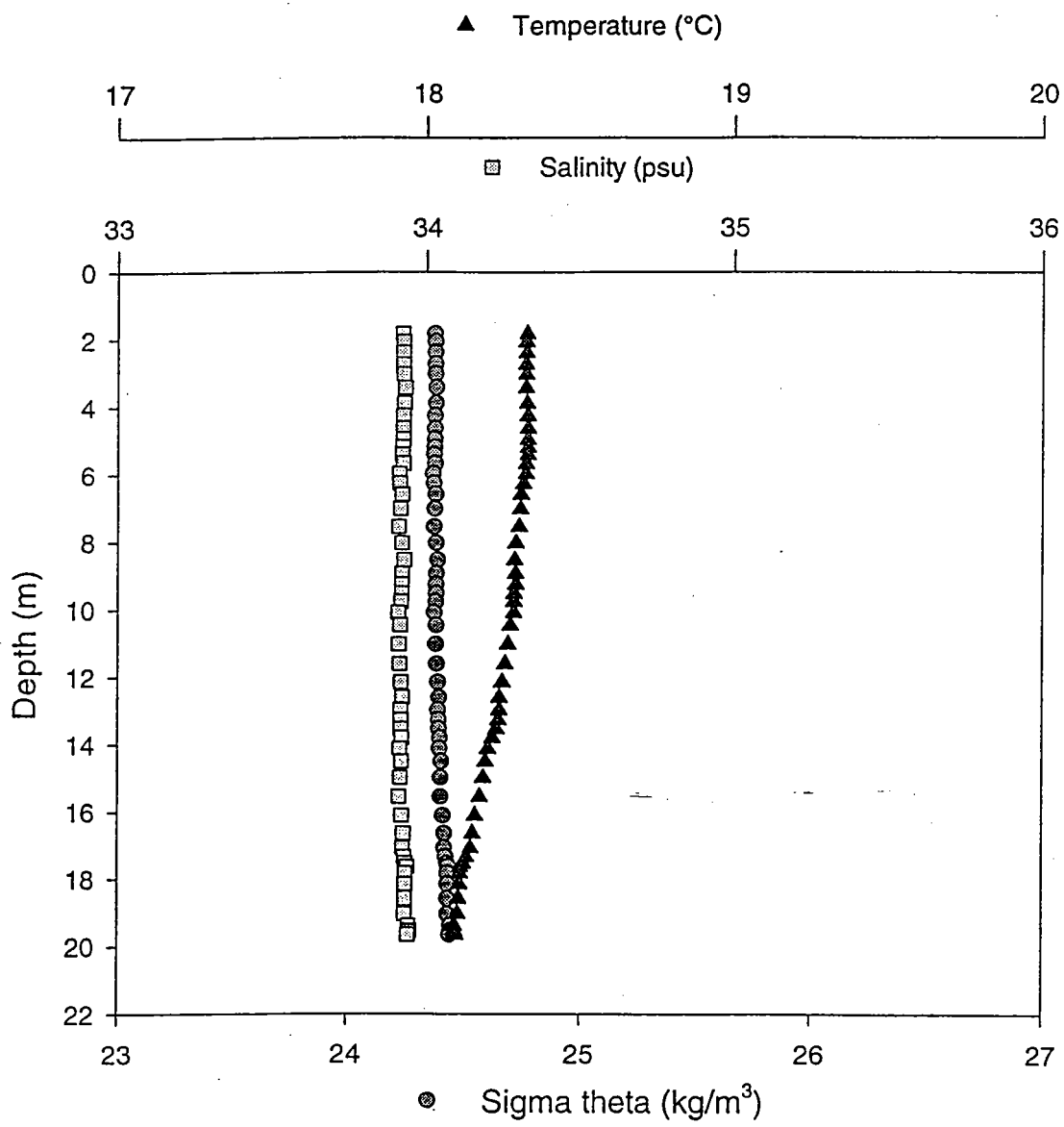

Figure A. 34 Station 4.1 CTD
April 25, 1996

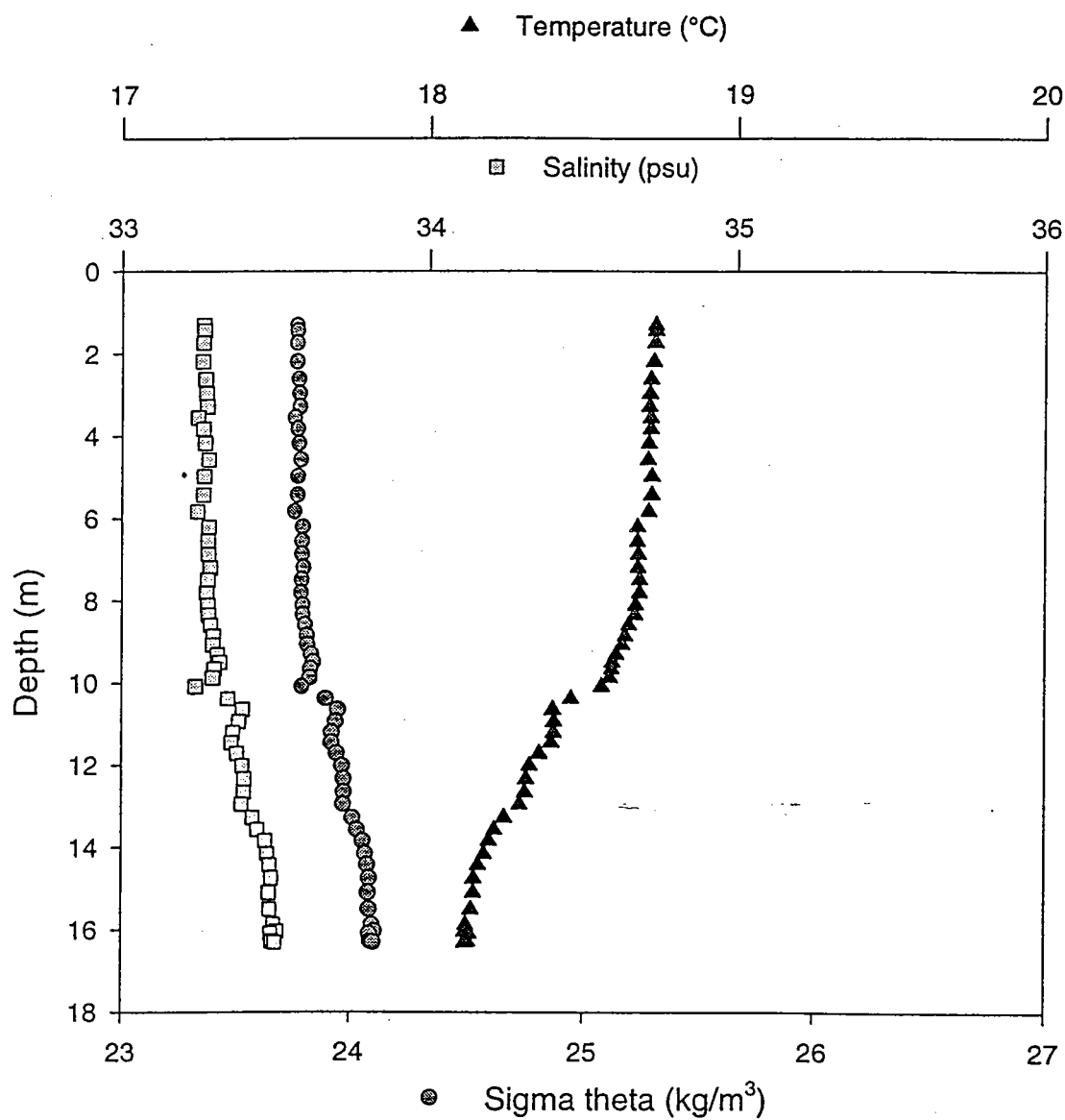

Figure A. 35 Station 4.2 CTD
April 25, 1996

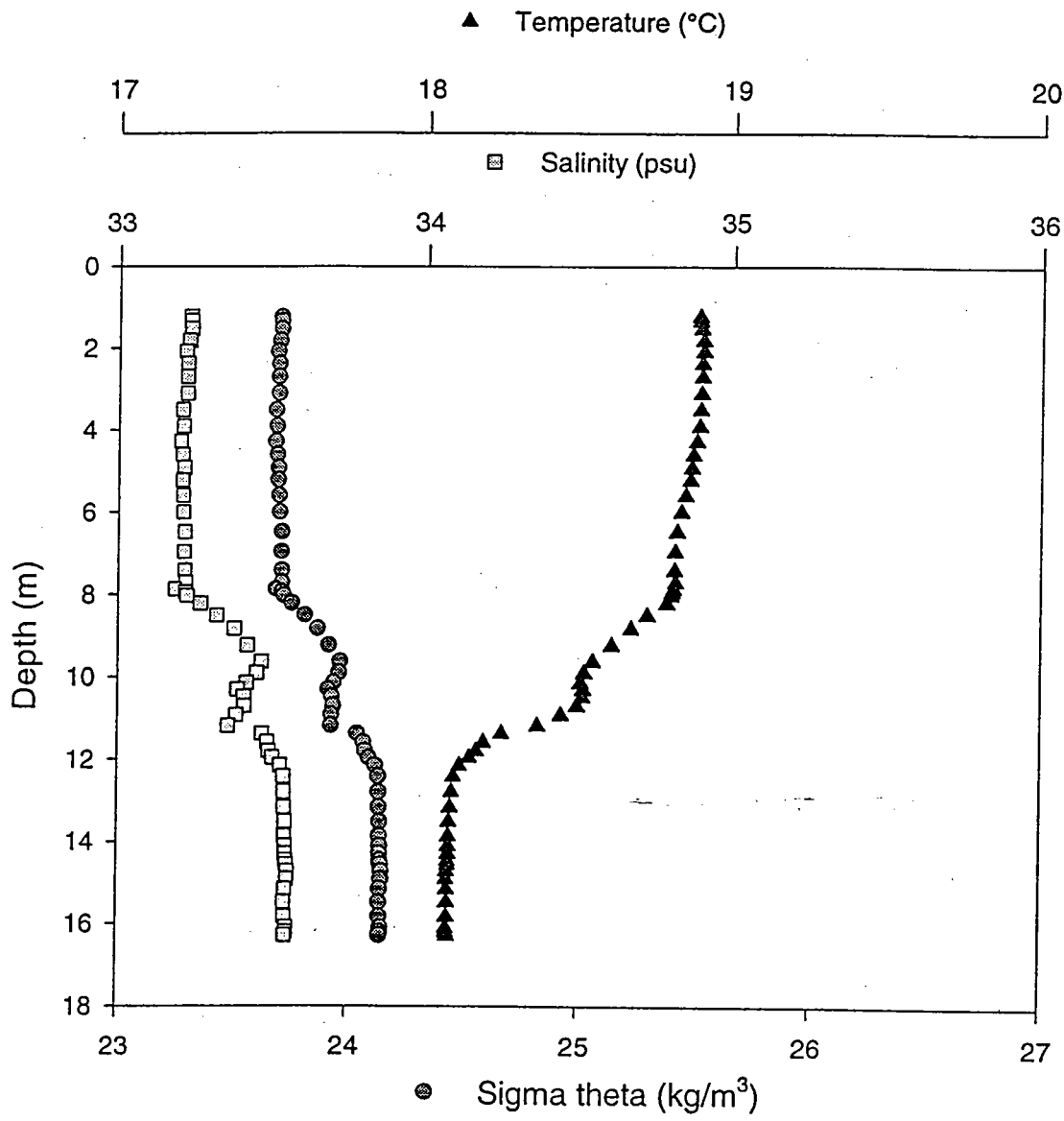
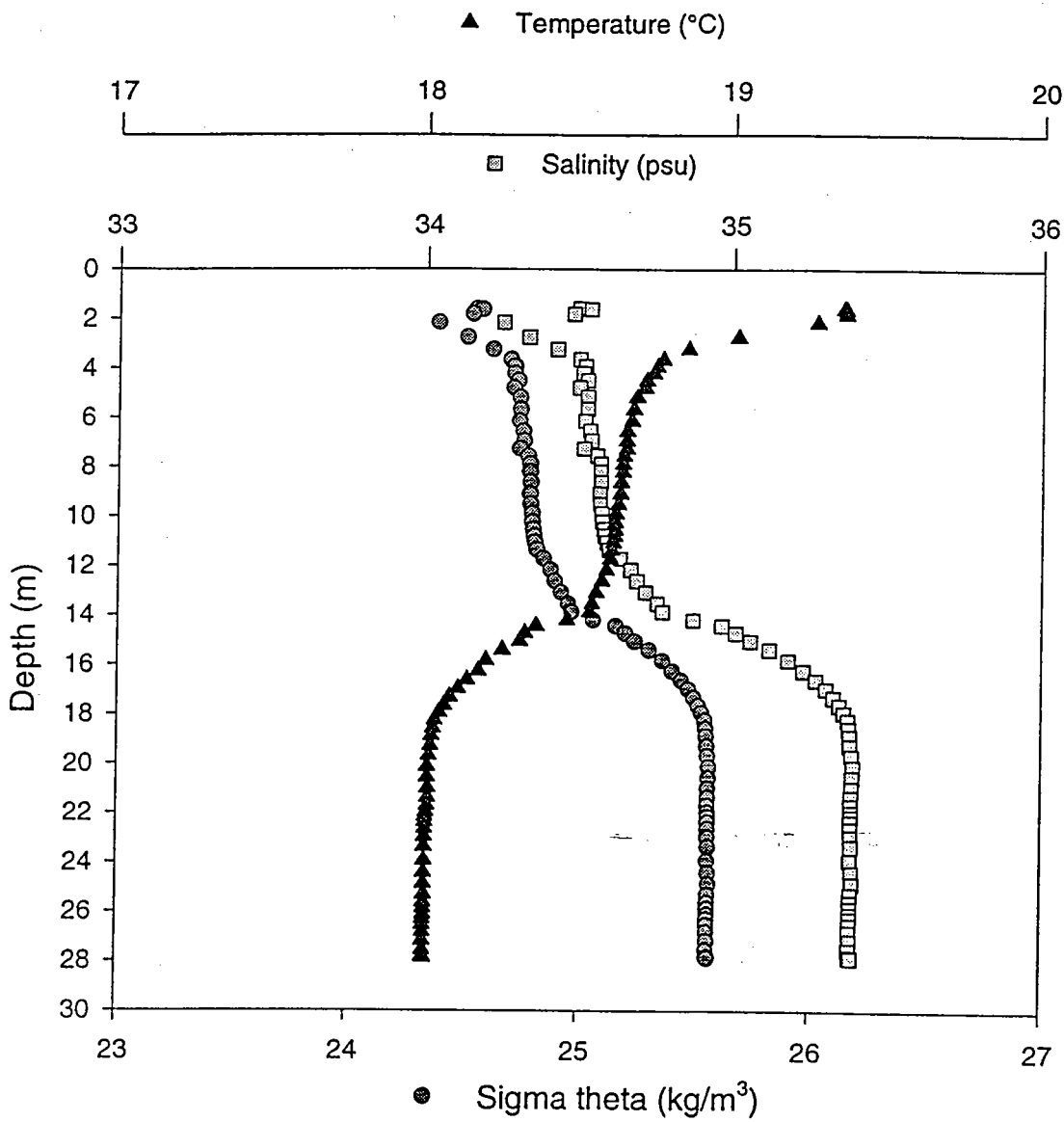

Figure A. 36 Station 4.3 CTD
April 25, 1996

(= W27)



IX. Appendix B - Sub-Surface Light Field Estimation Statistics

The following pages contain tables containing the statistics for calculation of the sub-surface light field. The column channel refers to the optical channel; min and max depths are the minimum and maximum depths used in the calculation; n points are the number of points used in the calculation; b0 is the intercept of the regression – the estimated sub-surface light (irradiance and radiance); b1 is the slope of the regression – the estimated attenuation coefficient, min, max, and mean refer to the minimum, maximum and mean irradiance or radiance values used in the calculation; and std dev, var, uncertainty, and abdev refer to the estimates of the intercept.

channel	min depth	max depth	n points	b0	b1	min	max	mean	std dev	var	uncertainty	abdev
1.1 Upcast												
ed380	0.5	3	6	48.8334	0.28	0.78	23.74	4.19	3.43	4.56	1.19	0.04
ed412	0.5	3	6	89.2998	0.45	6.87	56.56	19.38	2.12	1.76	1.15	0.03
ed443	0.5	3	6	104.2881	0.59	18.53	76.75	37.54	1.66	1.29	1.13	0.03
ed490	0.5	3	6	110.4799	0.74	39.55	92.99	60.92	1.36	1.10	1.11	0.02
ed510	0.5	3	6	109.9582	0.78	46.42	94.98	66.90	1.30	1.07	1.08	0.02
ed555	0.5	3	6	114.1327	0.80	55.26	100.48	74.92	1.25	1.05	1.10	0.02
lu380	0.5	3	2	0.0954	0.24	0.02	0.04	0.03	2.01	1.63	inf	0.00
lu412	0.5	3	6	0.2560	0.44	0.02	0.16	0.05	2.21	1.87	1.16	0.04
lu443	0.5	3	6	0.4579	0.55	0.07	0.33	0.15	1.76	1.38	1.11	0.03
lu490	0.5	3	6	0.8647	0.69	0.26	0.70	0.42	1.43	1.13	1.07	0.02
lu510	0.5	3	6	0.9243	0.72	0.35	0.83	0.54	1.36	1.10	1.06	0.01
lu555	0.5	3	6	1.1122	0.78	0.49	0.96	0.69	1.27	1.06	1.04	0.01
lu683	0.5	3	6	0.2202	0.58	0.04	0.16	0.08	1.69	1.32	1.09	0.02
1.2 Downcast												
ed380	0.5	3	6	29.4509	0.14	0.05	5.03	0.58	6.16	27.26	1.43	0.07
ed412	0.5	3	6	58.7055	0.28	0.89	18.67	4.51	3.35	4.31	1.17	0.03
ed443	0.5	3	6	80.4318	0.39	3.91	34.76	12.33	2.37	2.10	1.11	0.02
ed490	0.5	3	6	97.6456	0.53	12.46	55.63	26.96	1.79	1.40	1.08	0.02
ed510	0.5	3	6	96.6105	0.58	16.33	65.42	32.50	1.70	1.32	1.15	0.03
ed555	0.5	3	6	95.4274	0.65	23.34	72.22	40.56	1.53	1.20	1.16	0.03
lu380	0.5	3										
lu412	0.5	3	3	0.1857	0.25	0.02	0.05	0.03	1.74	1.36	2.33	0.04
lu443	0.5	3	6	0.3557	0.37	0.01	0.15	0.05	2.52	2.35	1.13	0.03
lu490	0.5	3	6	0.7421	0.54	0.10	0.43	0.21	1.81	1.42	1.10	0.02
lu510	0.5	3	6	0.9365	0.57	0.15	0.57	0.31	1.69	1.32	1.08	0.02
lu555	0.5	3	6	1.1864	0.64	0.28	0.80	0.49	1.52	1.19	1.06	0.01
lu683	0.5	3	6	0.3466	0.42	0.02	0.16	0.06	2.18	1.83	1.09	0.02

channel	min depth	max depth	n points	b0	b1	min	max	mean	std dev	var	uncertainty	abdev
1.2 Upcast												
ed380	0.5	3	6	22.5054	0.14	0.05	11.77	0.49	7.76	66.47	1.66	0.13
ed412	0.5	3	6	47.5527	0.27	0.82	30.99	3.98	3.80	5.92	1.33	0.06
ed443	0.5	3	6	61.0742	0.41	3.75	48.03	11.28	2.54	2.38	1.29	0.04
ed490	0.5	3	6	77.2208	0.56	12.33	65.33	25.32	1.83	1.44	1.17	0.03
ed510	0.5	3	6	77.4834	0.61	16.46	69.72	30.60	1.69	1.31	1.18	0.03
ed555	0.5	3	6	78.7794	0.68	23.68	73.55	38.52	1.50	1.18	1.16	0.02
lu380	0.5	3										
lu412	0.5	3	2	0.2725	0.17	0.03	0.11	0.06	2.39	2.14	inf	0.00
lu443	0.5	3	6	0.3796	0.34	0.01	0.25	0.05	2.94	3.19	1.33	0.08
lu490	0.5	3	6	0.9072	0.47	0.09	0.62	0.21	2.06	1.69	1.22	0.05
lu510	0.5	3	6	1.1155	0.51	0.15	0.79	0.30	1.91	1.52	1.19	0.04
lu555	0.5	3	6	1.4130	0.57	0.26	1.07	0.49	1.71	1.34	1.15	0.04
lu683	0.5	3	6	0.3911	0.39	0.02	0.26	0.06	2.50	2.32	1.26	0.06
1.3 Downcast												
ed380	0.5	3	5	3.4900	0.23	0.03	0.45	0.12	2.99	3.32	1.18	0.02
ed412	0.5	3	5	9.8880	0.35	0.37	2.30	0.89	2.15	1.79	1.27	0.03
ed443	0.5	3	5	13.9971	0.46	1.36	4.97	2.50	1.73	1.35	1.31	0.03
ed490	0.5	3	5	18.5978	0.58	3.74	9.10	5.57	1.46	1.15	1.34	0.03
ed510	0.5	3	5	19.5960	0.61	4.64	10.33	6.61	1.41	1.12	1.35	0.03
ed555	0.5	3	5	20.6226	0.66	6.09	11.97	8.14	1.34	1.09	1.36	0.03
lu380	0.5	3										
lu412	0.5	3										
lu443	0.5	3	5	0.0469	0.45	0.00	0.02	0.01	1.75	1.37	1.35	0.03
lu490	0.5	3	5	0.1118	0.59	0.02	0.05	0.03	1.46	1.15	1.28	0.03
lu510	0.5	3	5	0.1373	0.62	0.03	0.07	0.05	1.39	1.12	1.29	0.03
lu555	0.5	3	5	0.1722	0.68	0.05	0.10	0.07	1.31	1.08	1.27	0.02
lu683	0.5	3	5	0.0391	0.45	0.00	0.01	0.01	1.73	1.35	1.53	0.04
1.3 Upcast												
ed380	0.5	3	6	2.8067	0.23	0.02	1.14	0.16	4.16	7.61	1.19	0.05
ed412	0.5	3	6	8.5263	0.36	0.28	4.32	1.14	2.70	2.69	1.09	0.02
ed443	0.5	3	6	12.7750	0.48	1.15	7.99	3.07	2.03	1.65	1.05	0.01
ed490	0.5	3	6	17.8744	0.60	3.40	12.84	6.64	1.63	1.27	1.03	0.01
ed510	0.5	3	6	19.2474	0.63	4.32	14.28	7.88	1.55	1.21	1.03	0.01
ed555	0.5	3	6	20.6797	0.68	5.76	15.98	9.62	1.46	1.15	1.03	0.01
lu380	0.5	3										
lu412	0.5	3										
lu443	0.5	3	6	0.0455	0.46	0.00	0.03	0.01	2.15	1.80	1.09	0.02
lu490	0.5	3	6	0.1191	0.58	0.02	0.08	0.04	1.69	1.32	1.06	0.01
lu510	0.5	3	6	0.1480	0.61	0.03	0.11	0.06	1.60	1.25	1.05	0.01
lu555	0.5	3	6	0.1925	0.66	0.05	0.15	0.09	1.48	1.16	1.06	0.01
lu683	0.5	3	6	0.0439	0.44	0.00	0.03	0.01	2.20	1.86	1.15	0.04

channel	min depth	max depth	n points	b0	b1	min	max	mean	std dev	var	uncertainty	abdev
2.2 Upcast												
ed380	0.5	3	5	20.8160	0.15	0.05	2.12	0.30	4.58	10.16	1.55	0.05
ed412	0.5	3	5	49.5930	0.28	0.80	10.89	2.92	2.79	2.86	1.16	0.02
ed443	0.5	3	5	67.0521	0.42	3.75	23.04	9.19	2.03	1.65	1.20	0.02
ed490	0.5	3	5	81.2549	0.56	12.36	40.46	22.25	1.58	1.23	1.17	0.02
ed510	0.5	3	5	83.6540	0.61	16.21	45.56	27.17	1.49	1.17	1.14	0.02
ed555	0.5	3	5	83.9235	0.68	23.03	52.12	34.75	1.37	1.10	1.15	0.02
lu380	0.5	3										
lu412	0.5	3										
lu443	0.5	3	5	0.2220	0.41	0.01	0.08	0.03	2.08	1.71	1.20	0.03
lu490	0.5	3	5	0.4406	0.64	0.10	0.25	0.16	1.46	1.16	1.22	0.03
lu510	0.5	3	5	0.5375	0.69	0.16	0.35	0.24	1.36	1.10	1.23	0.03
lu555	0.5	3	5	0.7234	0.79	0.33	0.53	0.44	1.22	1.04	1.22	0.03
lu683	0.5	3	5	0.1728	0.52	0.02	0.08	0.04	1.72	1.34	1.15	0.02
2.3 Downcast												
ed380	0.5	3	6	34.7401	0.12	0.03	5.33	0.47	6.78	39.09	1.32	0.05
ed412	0.5	3	6	74.7048	0.26	0.82	22.62	4.80	3.47	4.70	1.19	0.04
ed443	0.5	3	6	95.5184	0.40	4.64	42.90	15.19	2.31	2.02	1.14	0.03
ed490	0.5	3	6	108.7289	0.58	17.30	67.50	36.29	1.67	1.30	1.12	0.03
ed510	0.5	3	6	103.1470	0.65	23.27	70.71	43.29	1.53	1.20	1.15	0.03
ed555	0.5	3	6	105.1371	0.73	34.80	79.38	55.70	1.37	1.11	1.14	0.03
lu380	0.5	3										
lu412	0.5	3	2	0.1371	0.23	0.02	0.04	0.03	1.49	1.17	inf	0.00
lu443	0.5	3	6	0.2914	0.35	0.01	0.12	0.03	2.60	2.48	1.07	0.01
lu490	0.5	3	6	0.6347	0.51	0.07	0.36	0.16	1.84	1.45	1.04	0.01
lu510	0.5	3	6	0.7805	0.55	0.11	0.47	0.23	1.73	1.35	1.03	0.01
lu555	0.5	3	6	1.0226	0.60	0.20	0.66	0.37	1.58	1.23	1.03	0.01
lu683	0.5	3	6	0.3221	0.42	0.02	0.15	0.06	2.18	1.83	1.09	0.02
2.6 Upcast												
ed380	0.5	3	5	61.6049	0.53	7.11	26.41	14.19	1.64	1.28	1.37	0.04
ed412	0.5	3	5	115.1391	0.68	30.93	68.98	47.15	1.35	1.09	1.23	0.03
ed443	0.5	3	5	141.6880	0.77	56.31	99.72	75.79	1.23	1.05	1.20	0.03
ed490	0.5	3	5	156.3724	0.84	82.60	123.59	101.92	1.16	1.02	1.18	0.02
ed510	0.5	3	5	161.1089	0.83	86.85	126.45	105.73	1.16	1.02	1.22	0.03
ed555	0.5	3	5	153.5599	0.84	86.76	122.78	104.43	1.14	1.02	1.18	0.02
lu380	0.5	3	4	0.0786	0.52	0.02	0.03	0.02	1.42	1.13	2.33	0.06
lu412	0.5	3	5	0.1843	0.71	0.06	0.12	0.08	1.31	1.07	1.24	0.03
lu443	0.5	3	5	0.3344	0.80	0.16	0.25	0.20	1.19	1.03	1.19	0.03
lu490	0.5	3	5	0.5960	0.89	0.40	0.51	0.45	1.10	1.01	1.11	0.02
lu510	0.5	3	5	0.6230	0.89	0.42	0.53	0.47	1.09	1.01	1.08	0.01
lu555	0.5	3	5	0.5219	0.90	0.37	0.46	0.41	1.08	1.01	1.07	0.01
lu683	0.5	3	5	0.0562	0.70	0.02	0.03	0.02	1.34	1.09	1.07	0.01

channel	min depth	max depth	n points	b0	b1	min	max	mean	std dev	var	uncertainty	abdev
3.1 Upcast												
ed380	0.5	3	6	37.5926	0.26	0.35	14.99	2.53	3.83	6.08	1.41	0.07
ed412	0.5	3	6	75.5791	0.42	3.75	39.64	13.22	2.36	2.08	1.27	0.05
ed443	0.5	3	6	100.6542	0.53	11.81	58.65	28.30	1.81	1.42	1.21	0.04
ed490	0.5	3	6	117.4772	0.66	29.06	78.55	50.65	1.46	1.15	1.18	0.04
ed510	0.5	3	6	116.7089	0.70	34.87	83.22	56.68	1.39	1.11	1.16	0.03
ed555	0.5	3	6	115.7359	0.74	42.57	85.93	63.51	1.31	1.08	1.15	0.03
lu380	0.5	3										
lu412	0.5	3	5	0.1902	0.41	0.02	0.10	0.04	1.98	1.60	1.28	0.05
lu443	0.5	3	6	0.3616	0.53	0.05	0.24	0.10	1.82	1.43	1.11	0.03
lu490	0.5	3	6	0.7829	0.68	0.22	0.62	0.36	1.46	1.15	1.09	0.02
lu510	0.5	3	6	0.9574	0.70	0.31	0.76	0.47	1.39	1.12	1.09	0.02
lu555	0.5	3	6	1.1707	0.75	0.48	0.96	0.66	1.30	1.07	1.09	0.02
lu683	0.5	3	6	0.2128	0.55	0.03	0.15	0.07	1.75	1.37	1.14	0.03

X. Appendix C - Example Profile Header Information

The following text is an example of the header information found in each BBOP processed profile file.

```
<cruise_info>
filename p960422a
date 04-22-1996
day_of_year 113
day_since_010192 1574
file_created 15:56:31
cruise 1.1
position 80 43.3 31 57.9
longitude 80 43.3
latitude 31 57.9
sky_state clear
operator_name kjw
sun_position 3
cruise_id ferrel april 96 cruise
session_started 15:56:42
depth_offset .29
transmiss_offset 0.002
trans_air_calib 5.1
trans_factory_air_calib 4.711
trans_sn 664
most_recent_dark_file
deck_comparison_file
cal_date_uw9643 032696
cal_date_sfc9644 032696
downcast_ended 16:00:15.19 339
upcast_ended 16:01:07.601 418
collection_software_version prrprof_002086c
number_units 1
collection_cal_file 96439644.cfl;pr-600 #9643/9644 calibration file 3/26/96 cac
lcd_calib_file 0 /csc/nep1/coors/bbops/BUILD/calib/unit0_032696.cfl
1 /csc/nep1/coors/bbops/BUILD/calib/unit1_032696.cfl
2 /csc/nep1/coors/bbops/BUILD/calib/unit2_032696.cfl
lcdfile_created Dec 16 1996 17:05:44
castid index 1pr_r_record 1depth
p960422a.dt1 1.3100000e+02 1.3100000e+02 1.6445010e+00
p960422a.db1 2.6300000e+02 2.6300000e+02 1.4967300e+01
p960422a.ub1 3.0700000e+02 3.0700000e+02 1.4992800e+01
p960422a.ut1 4.0500000e+02 4.0500000e+02 3.7331600e-01
```

```

<sampled_parameters>
lprc_record 1 1 0
led380 0 -0.008677 0.00016
led412 0 -0.021592 9.5e-05
led443 0 -0.022113 0.000116
led490 0 -0.02328 0.000272
led510 0 -0.022617 0.000108
led555 0 -0.02301 0.000459
lpar 0 -9.05074 0.000337
ledgnd 0 1 0
ltemp 0 0.141923 0.080084
ldepth 0 0. 9.37400e-01 8.38842e+01 2.66735e+01 0.9374 83.8842 26.9635 0 0
lxmiss 0 0. 5.55901e-02 -1.89174e-03 0.05 0
lqsp 0 -1.61e-17 0.0018
ltilt 0 0.04178 2.68617
lroll 0 0.041514 2.69727
lfluor 0 1 0
2lu380 0 -0.151959 0.000221
2lu412 0 -0.509911 -6.8e-05
2lu443 0 -0.911266 0.000233
2lu490 0 -1.00583 0.00018
2lu510 0 -1.24899 0.000363
2lu555 0 -1.75531 0.00018
2lu683 0 -1.55517 9.5e-05
2lugnd 0 1 0
3es380 0 -0.03292 0.000205
3es412 0 -0.0327 -0.000888
3es443 0 -0.0342 -3.6e-05
3es490 0 -0.03342 -0.000291
3es510 0 -0.03317 -0.00028
3es555 0 -0.03269 0.000142
3par 0 -10.8742 -4e-05
3edgnd 0 1 0
<derived_parameters>
aq-1Tilt-1Roll
kq-led412
d-1fluor
d-1temp
d-1xmiss
d-d-1fluor
d-d-1temp
d-d-1xmiss
m-d-d-1temp
bin_0.5_1depth
ptsbin_0.5

```

kc-1ed380
kc-1ed412
kc-1ed443
kc-1ed490
kc-1ed510
kc-1ed555
<data>

<filters_used>

prrrcalz -o 1depth 0.9374 83.8842 26.6735
/csc/nep1/coors/bbops/BUILD/apr96ferrel/lcd/p960422a.lcd outfile26473
bboprecal -r 1xmiss 0.0555901 -0.00189174
/csc/nep1/coors/bbops/BUILD/apr96ferrel/lcd/p960422a.lcd outfile27117
bbopradq -fa 1ed380 6.327000e-03 p960422a.lcd outqp960422a.lcd
bbopradq -fa 1ed412 1.000000e-04 p960422a.lcd outqp960422a.lcd
bbopradq -fa 1ed443 1.000000e-04 p960422a.lcd outqp960422a.lcd
bbopradq -fa 1ed490 1.000000e-04 p960422a.lcd outqp960422a.lcd
bbopradq -fa 1ed510 2.000000e-04 p960422a.lcd outqp960422a.lcd
bbopradq -fa 1ed555 1.000000e-04 p960422a.lcd outqp960422a.lcd
bbopradq -fa 3es380 1.000000e-04 p960422a.lcd outqp960422a.lcd
bbopradq -fa 3es412 1.000000e-03 p960422a.lcd outqp960422a.lcd
bbopradq -fa 3es443 1.000000e-03 p960422a.lcd outqp960422a.lcd
bbopradq -fa 3es490 1.000000e-05 p960422a.lcd outqp960422a.lcd
bbopradq -fa 3es510 1.000000e-05 p960422a.lcd outqp960422a.lcd
bbopradq -fa 3es555 1.000000e-04 p960422a.lcd outqp960422a.lcd
bbopradq -fa 3par 1.000000e-01 p960422a.lcd outqp960422a.lcd
bbopradq -fa 2lu380 1.000000e-02 p960422a.lcd outqp960422a.lcd
bbopradq -fa 2lu412 1.000000e-02 p960422a.lcd outqp960422a.lcd
bbopradq -fa 2lu443 1.000000e-03 p960422a.lcd outqp960422a.lcd
bbopradq -fa 2lu490 1.000000e-03 p960422a.lcd outqp960422a.lcd
bbopradq -fa 2lu510 1.000000e-03 p960422a.lcd outqp960422a.lcd
bbopradq -fa 2lu555 2.000000e-04 p960422a.lcd outqp960422a.lcd
bbopradq -fa 2lu683 2.000000e-04 p960422a.lcd outqp960422a.lcd
bbopradq -fa 1xmiss 3.000000e+01 p960422a.lcd outqp960422a.lcd
bbopradq -fa 1fluor 1.000000e-03 p960422a.lcd outqp960422a.lcd
bbopangq 1Tilt 1Roll 10 2 inqp960422a.lcd outqp960422a.lcd
bbopkq -s 1ed412 10 0.9 4.5 inqp960422a.lcd outqp960422a.lcd
bbopdespike -d 1fluor 0.03 10 indqp960422a.lcd outdqp960422a.lcd
bbopdespike -d 1temp 0.05 10 indqp960422a.lcd outdqp960422a.lcd
bbopdespike -d 1xmiss 0.05 10 indqp960422a.lcd outdqp960422a.lcd
bbopdespike -d d-1fluor 0.03 10 indqp960422a.lcd outdqp960422a.lcd
bbopdespike -d d-1temp 0.05 10 indqp960422a.lcd outdqp960422a.lcd
bbopdespike -d d-1xmiss 0.05 10 indqp960422a.lcd outdqp960422a.lcd
bbopmovavg -f d-d-1temp 5.0 dqp960422a.lcd mdqp960422a.lcd
bbopbin -b 0.5 mdqp960422a.lcd

bbopkc -s 1ed380 5 inkbmdqp960422a.lcd.1 outkbmdqp960422a.lcd.1
bbopkc -s 1ed412 5 inkbmdqp960422a.lcd.1 outkbmdqp960422a.lcd.1
bbopkc -s 1ed443 5 inkbmdqp960422a.lcd.1 outkbmdqp960422a.lcd.1
bbopkc -s 1ed490 5 inkbmdqp960422a.lcd.1 outkbmdqp960422a.lcd.1
bbopkc -s 1ed510 5 inkbmdqp960422a.lcd.1 outkbmdqp960422a.lcd.1
bbopkc -s 1ed555 5 inkbmdqp960422a.lcd.1 outkbmdqp960422a.lcd.1

XI. Appendix D - Calibration Certificates

The following pages contain the calibration certificates for the PRR600 system, and the SAFire.

uncorrected emission output values by correction constants. These correction constants are supplied below.

<u>Emission λ</u>	<u>Correction Constant</u>
228	20.4
265	5.84
313	6.65
340	5.18
365	6.11
400	4.46
430	2.90
460	2.82
490	2.12
510	2.01
540	2.22
590	2.43
620	0.67
650	0.88
690	1
810	1.68

Biospherical Instruments Inc.

EVALUATION FORM for PRR Spectroradiometer

Calibration Date: 3/26/96

Form: 7/11/96

Model Number: PRV-600S

Serial Number: 9643

Operator: JCE/LFG

Standard Lamp: 94531 (10/11/95) for Irradiance, 94532 (10/11/95) for Radiance.

Ch Tag	λ (nm)	Lamp Irradiance	Immersion Coefficient	Calibration Voltage - Dark ³⁾	Calibration Voltage - Light	Calibration Factor - Dry (V/ μ W)	Calibration Factor - Wet (V/ μ W)	Max E (Dry)	
DOWNWELLING IRRADIANCE CHANNELS									
Irradiance Units: μ W/cm ² ·nm, E = Irradiance									
1	0	380	1.486	0.671	0.000160	-0.019050	-0.012927	-0.008677	773.6
2	0	412	2.559	0.677	0.000095	-0.081553	-0.031907	-0.021592	313.4
3	0	443	3.906	0.682	0.000116	-0.126520	-0.032421	-0.022113	308.4
4	0	490	6.483	0.690	0.000272	-0.218429	-0.033732	-0.023280	296.5
5	0	510	7.683	0.694	0.000108	-0.250415	-0.032609	-0.022617	306.7
6	0	555	10.536	0.701	0.000459	-0.345228	-0.032809	-0.023010	304.8
7	0	PAR ⁴⁾	0.0152	0.686	0.000337	-0.200664	-13.196577	-9.050741	0.758 ⁴⁾
8	0	Gnd. ⁵⁾	0.000309	Volts					

Calibration Factor: WET = ((Light - Dark) x Immers. Coeff.)/Lamp Output

DRY = (Light - Dark)/Lamp Output

Ch Tag	λ (nm)	Lamp Irradiance @ 50 cm	Immersion Coefficient	Plaque Reflectivity	Calibration Voltage - Dark	Calibration Voltage - Blocked ³⁾	Calibration Voltage - Light	Calibration Factor - Wet (V/ μ W)	Max L (Wet)		
UPWELLING RADIANCE CHANNELS											
Radiance Units: μ W/cm ² ·nm·sr, L = Radiance											
1	1	380	1.308	1.765	0.985	0.011	0.000133	0.000133	-0.002922	-0.151959	65.8
2	1	412	2.275	1.758	0.985	0.020	0.000209	0.000202	-0.017559	-0.509911	19.6
3	1	443	3.514	1.752	0.985	0.031	0.000192	0.000186	-0.048676	-0.911266	11.0
4	1	490	5.911	1.745	0.984	0.051	0.000122	0.000106	-0.090184	-1.005825	9.9
5	1	510	7.038	1.743	0.984	0.061	0.000272	0.000261	-0.133038	-1.248987	8.0
6	1	555	9.746	1.738	0.984	0.085	0.000124	0.000083	-0.258677	-1.755312	5.7
7	1	683	16.755	1.730	0.984	0.146	0.000027	-0.000057	-0.392216	-1.555169	6.4
8	1	Gnd. ⁵⁾	0.000124	Volts							

Dry Radiance = (Lamp Output x Plaque Reflectivity x Lamp Distance Factor)/ π

Lamp Distance Factor = (50 cm)²/(300 cm)²

Calibration Factor: WET = (Light - Dark)/(Dry Radiance x Immersion Coefficient)

9	0	TEMPERATURE ⁶⁾	Temperature (°C) = (Voltage - Offset)/Scale	
		Scale	0.1419	
		Offset	0.0801	
10	0	PRESSURE/DEPTH ⁷⁾	Pressure/Depth (dbars or meters) = (a x Voltage ²) + (b x Voltage) + c	
		Scale Factor "a"	0.9374	
		Scale Factor "b"	83.8842	
		Offset "c"	26.9636	

NOMINAL TO ACTUAL VOLTAGE CONVERSION FACTORS⁸⁾ (For use with external sensors, only, see manual)

	Irr. Array	Rad. Array
Scale Factor	1.057679	1.074227
Offset	0.000206	0.000278
Full Scale Voltage	9.4547	9.3090

FIRMWARE VERSIONS

	Tag 0	Tag 1
Underwater ROM	2765B	2043A

Notes:

- Annual calibration is recommended.
- Calibrations were performed at approximately 20 to 30 °C.
- "Dark" irradiance and "Blocked" radiance values represent a blocking of the calibration source. These values should not be used as the "Offset" when entering values into the calibration file. Use the totally dark sensor values obtained at the temperature where the instrument will be used.
- PAR irradiance units are μ Einsteins/cm²·sec.
- Nominal/Typical value(s).
- For conversion of area to solid angle, a factor (divisor) of π is incorporated.
- Water temperature sensor.
- A change in depth of 1 meter in seawater corresponds to approximately a 1 dbar change in pressure.
- These channels/sensors were not evaluated during this service period.

Biospherical Instruments Inc.
CALIBRATION CERTIFICATE for PRR Spectroradiometer

Calibration Date: 3/26/96
 Model Number: PRV-600S
 Serial Number: 9643
 Operator: JCE/LFG

Form: 7/11/96

OPTIONAL CHANNELS

Ch Tag

11	0	Transmissometer ¹⁾	Output = (Voltage - Offset)/Scale
		Scale Factor	1.0 Volts/Volt
		Offset	0.0 Volts
12	0	Scalar PAR: QSP-200 S/N 4443 ²⁾	quanta/(cm ² ·sec) = (Voltage - Offset)/Scale
		Scale Factor (Wet)	-1.161E-17 Volts/(quanta/cm ² ·sec)
		Offset	0.0009 Volts
13	0	AXIS 1 ANGLE SENSOR - "TILT" ²⁾	Degrees = (Voltage - Offset)/Scale
		Scale Factor	0.0418
		Offset	2.6882
14	0	AXIS 2 ANGLE SENSOR - "ROLL" ²⁾	Degrees = (Voltage - Offset)/Scale
		Scale Factor	0.0415
		Offset	2.6973
15	0	Light Scattering Sensor ¹⁾	Output = (Voltage - Offset)/Scale
		Scale Factor	1.0 Volts/Volt
		Offset	0.0 Volts
16	0	Fluorometer ¹⁾	Output = (Voltage - Offset)/Scale
		Scale Factor	1.0 Volts/Volt
		Offset	0.0 Volts

Notes:

- 1) These sensors are not calibrated at BSI. When applicable, see the manufacturers' specifications.
- 2) These channels/sensors were not evaluated during this service period.

Biospherical Instruments Inc.
CALIBRATION CERTIFICATE for PRR Spectroradiometer

DO NOT DESTROY
 Biospherical Instruments Inc.
 CALIBRATION DATA

Calibration Date: 1/23/96
 Model Number: PRV-600S
 Serial Number: 9643
 Operator: JCE/LFG
 Standard Lamp: 91771 (05/30/95)

Form: 1/24/96

Ch Tag	λ (nm)	Lamp Irradiance	Immersion Coefficient	Calibration Voltage - Dark ³⁾	Calibration Voltage - Light	Calibration Factor - Dry (V/ μ W)	Calibration Factor - Wet (V/ μ W)	Max E (Dry)	
DOWNWELLING IRRADIANCE CHANNELS									
Irradiance Units: μ W/cm ² -nm, E = Irradiance									
1	0	380	1.397	0.000132	-0.018129	-0.013074	-0.008775	764.9	
2	0	412	2.411	0.000516	-0.077541	-0.032371	-0.021906	308.9	
3	0	443	3.701	0.000113	-0.120950	-0.032714	-0.022313	305.7	
4	0	490	6.159	0.000302	-0.209334	-0.034039	-0.023491	293.8	
5	0	510	7.302	0.000168	-0.240489	-0.032957	-0.022859	303.4	
6	0	555	10.041	0.000465	-0.332822	-0.033194	-0.023279	301.3	
7	0	PAR ⁴⁾	0.014	0.000330	-0.194557	-13.767821	-9.442522	0.726 ⁴⁾	
8	0	Gnd. ⁵⁾	0.000291	Volts					

Calibration Factor: WET = ((Light - Dark) x Immers. Coeff.)/Lamp Output
 DRY = (Light - Dark)/Lamp Output

Ch Tag	λ (nm)	Lamp Irradiance @ 50 cm	Immersion Coefficient	Plaque Reflectivity	Calibration Radiance ⁶⁾	Calibration Voltage - Dark	Calibration Voltage - Blocked ³⁾	Calibration Voltage - Light	Calibration Factor - Wet (V/ μ W)	Max L (Wet)
UPWELLING RADIANCE CHANNELS										
Radiance Units: μ W/cm ² -nm-sr, L = Radiance										
1	1	380	1.397	1.765	0.985	0.012	0.000221	0.000214	-0.003021	-0.150639
2	1	412	2.411	1.758	0.985	0.021	-0.000068	-0.000079	-0.018727	-0.505131
3	1	443	3.701	1.752	0.985	0.032	0.000233	0.000215	-0.050659	-0.900887
4	1	490	6.159	1.745	0.984	0.054	0.000180	0.000150	-0.092345	-0.988998
5	1	510	7.302	1.743	0.984	0.064	0.000363	0.000337	-0.136471	-1.235454
6	1	555	10.041	1.738	0.984	0.087	0.000180	0.000128	-0.263356	-1.734900
7	1	683	16.897	1.730	0.984	0.147	0.000095	-0.000003	-0.394184	-1.550051
8	1	Gnd. ⁵⁾	0.00019	Volts						

Dry Radiance = (Lamp Output x Plaque Reflectivity x Lamp Distance Factor)/ π
 Lamp Distance Factor = (50 cm)²/(300 cm)²
 Calibration Factor: WET = (Light - Dark)/(Dry Radiance x Immersion Coefficient)

9	0	TEMPERATURE ⁷⁾	Temperature (°C) = (Voltage - Offset)/Scale							
		Scale	0.1419							
		Offset	0.0801							
10	0	PRESSURE/DEPTH ⁸⁾	Pressure/Depth (dbars or meters) = (a x Voltage ²) + (b x Voltage) + c							
		Scale Factor "a"	0.9374							
		Scale Factor "b"	83.8842							
		Offset "c"	26.9636							

NOMINAL TO ACTUAL VOLTAGE CONVERSION FACTORS (For use with external sensors, only, see manual)

	Irr. Array	Rad. Array
Scale Factor	1.057679	1.074227
Offset	0.000205	0.000278
Full Scale Voltage	9.4547	9.3090

FIRMWARE VERSIONS

	Tag 0	Tag 1
Underwater ROM	2765B	2043A

Notes:

- Annual calibration is recommended.
- Calibrations were performed at approximately 20 to 30 °C.
- "Dark" irradiance and "Blocked" radiance values represent a blocking of the calibration source. These values should not be used as the "Offset" when entering values into the calibration file. Use the totally dark sensor values obtained at the temperature where the instrument will be used.
- PAR irradiance units are μ Einsteins/cm²-sec.
- Typical value(s).
- For conversion of area to solid angle, a factor (divisor) of Pi is incorporated.
- Water temperature sensor.
- A change in depth of 1 meter in seawater corresponds to approximately a 1 dbar change in pressure.

DO NOT DESTROY
Biospherical Instruments Inc.
CALIBRATION DATA

Biospherical Instruments Inc.
CALIBRATION CERTIFICATE for PRR Spectroradiometer

Calibration Date: 1/23/96 Form: 1/24/96
 Model Number: PRV-600S
 Serial Number: 9643
 Operator: JCE/LFG

OPTIONAL CHANNELS

Ch Tag			
11	0 Transmissometer ¹⁾	Output = (Voltage - Offset)/Scale	
	Scale Factor	1.0	Volts/Volt
	Offset	0.0	Volts
12	0 Scalar PAR: QSP-200 S/N 4443	quanta/(cm²-sec) = (Voltage - Offset)/Scale	
	Scale Factor (Wet)	-1.161E-17	Volts/(quanta/cm ² -sec)
	Offset	0.0009	Volts
13	0 AXIS 1 ANGLE SENSOR - "TILT"	Degrees = (Voltage - Offset)/Scale	
	Scale Factor	0.0418	
	Offset	2.6862	
14	0 AXIS 2 ANGLE SENSOR - "ROLL"	Degrees = (Voltage - Offset)/Scale	
	Scale Factor	0.0415	
	Offset	2.6973	
15	0 Light Scattering Sensor ¹⁾	Output = (Voltage - Offset)/Scale	
	Scale Factor	1.0	Volts/Volt
	Offset	0.0	Volts
16	0 Fluorometer ¹⁾	Output = (Voltage - Offset)/Scale	
	Scale Factor	1.0	Volts/Volt
	Offset	0.0	Volts

Notes:

1) These sensors are not calibrated at BSI. When applicable, see the manufacturers' specifications.

DO NOT DESTROY
Biospherical Instruments Inc.
CALIBRATION DATA

JB

Biospherical Instruments Inc.
CALIBRATION CERTIFICATE for PRR Spectroradiometer

Calibration Date: 1/24/96 Form: 1/25/96
 Model Number: PRV-610
 Serial Number: 9644
 Operator: JCE/LFG
 Standard Lamp: 91771 (05/30/95)

Ch	Tag	λ (nm)	Lamp Output	Calibration Voltage - Dark ³⁾	Calibration Voltage - Light	Calibration Factor - Dry (V/ μ W)	Max E (Dry)
SURFACE IRRADIANCE CHANNELS Irradiance Units: μ W/cm ² -nm, E = Irradiance							
1	2	380	1.397	0.000205	-0.045775	-0.032918	303.8
2	2	412	2.411	-0.000888	-0.079748	-0.032704	305.8
3	2	443	3.701	-0.000036	-0.126600	-0.034201	292.4
4	2	490	6.159	-0.000291	-0.206142	-0.033424	299.2
5	2	510	7.302	-0.000277	-0.242508	-0.033173	301.5
6	2	555	10.041	0.000142	-0.328101	-0.032691	305.9
7	2	PAR ⁴⁾	0.0142	-0.000040	-0.153967	-10.874195	0.920 ⁵⁾
8	2	Gnd. ⁵⁾	0.000095	Volts			

Calibration Factors: DRY = (Light - Dark)/Lamp Output

NOMINAL TO ACTUAL VOLTAGE CONVERSION FACTORS (For use with external sensors, only, see manual)

	Irr. Array
Scale	1.061494
Offset	0.000049
Full Scale Voltage	9.4207

FIRMWARE VERSION

	Tag 2
Surface ROM	2106B

Notes:

1. Annual calibration is recommended.
2. Calibrations were made at approximately 20 to 30 °C.
- 3) Dark values represent a blocking of the calibration source. These values should not be used as the 'offset' when entering values into the calibration file. Use the totally dark sensor values obtained at the temperature where the instrument will be used.
- 4) PAR Irradiance units are μ Einsteins/cm²-sec.
- 5) Typical value(s).